

Test Booklet Code & Serial No.

प्रश्नपत्रिका कोड व क्रमांक

**Paper-II**

**PHYSICAL SCIENCE**

**D**

**Signature and Name of Invigilator**

Seat No.

--	--	--	--	--	--	--	--	--	--

1. (Signature) .....

(In figures as in Admit Card)

(Name) .....

Seat No. ....

(In words)

2. (Signature) .....

(Name) .....

OMR Sheet No.

--	--	--	--	--	--	--	--	--	--

(To be filled by the Candidate)

**APR - 32224**

**Time Allowed : 2 Hours]**

**[Maximum Marks : 200**

**Number of Pages in this Booklet : 28**

**Number of Questions in this Booklet : 100**

**Instructions for the Candidates**

- Write your Seat No. and OMR Sheet No. in the space provided on the top of this page.
- This paper consists of **100** objective type questions. Each question will carry *two* marks. *All* questions of Paper II will be compulsory.
- At the commencement of examination, the question booklet will be given to the student. In the first 5 minutes, you are requested to open the booklet and compulsorily examine it as follows :
  - To have access to the Question Booklet, tear off the paper seal on the edge of this cover page. Do not accept a booklet without sticker-seal or open booklet.
  - Tally the number of pages and number of questions in the booklet with the information printed on the cover page. Faulty booklets due to missing pages/questions or questions repeated or not in serial order or any other discrepancy should not be accepted and correct booklet should be obtained from the invigilator within the period of 5 minutes. Afterwards, neither the Question Booklet will be replaced nor any extra time will be given. The same may please be noted.
  - After this verification is over, the OMR Sheet Number should be entered on this Test Booklet.
- Each question has four alternative responses marked (A), (B), (C) and (D). You have to darken the circle as indicated below on the correct response against each item.

**Example :** where (C) is the correct response.

**(A) (B) (C) (D)**
- Your responses to the items are to be indicated in the **OMR Sheet given inside the Booklet only**. If you mark at any place other than in the circle in the OMR Sheet, it will not be evaluated.
- Read instructions given inside carefully.
- Rough Work is to be done at the end of this booklet.
- If you write your Name, Seat Number, Phone Number or put any mark on any part of the OMR Sheet, except for the space allotted for the relevant entries, which may disclose your identity, or use abusive language or employ any other unfair means, you will render yourself liable to disqualification.
- You have to return original OMR Sheet to the invigilator at the end of the examination compulsorily and must not carry it with you outside the Examination Hall. You are, however, allowed to carry the Test Booklet and duplicate copy of OMR Sheet on conclusion of examination.
- Use only Blue/Black Ball point pen.
- Use of any calculator or log table, etc., is prohibited.
- There is no negative marking for incorrect answers.

**विद्यार्थ्यांसाठी महत्त्वाच्या सूचना**

- परिक्षार्थींनी आपला आसन क्रमांक या पृष्ठावरील वरच्या कोपऱ्यात लिहावा. तसेच आपणांस दिलेल्या उत्तरपत्रिकेचा क्रमांक त्याखाली लिहावा.
- सदर प्रश्नपत्रिकेत **100** बहुपर्यायी प्रश्न आहेत. प्रत्येक प्रश्नास **दोन** गुण आहेत. या प्रश्नपत्रिकेतील **सर्व** प्रश्न सोडविणे अनिवार्य आहे.
- परीक्षा सुरु झाल्यावर विद्यार्थ्यांला प्रश्नपत्रिका दिली जाईल. सुरुवातीच्या 5 मिनीटांमध्ये आपण सदर प्रश्नपत्रिका उघडून खालील बाबी अवश्य तपासून घ्याव्यात.
  - प्रश्नपत्रिका उघडण्यासाठी प्रश्नपत्रिकेवर लावलेले सील उघडवावे. सील नसलेली किंवा सील उघडलेली प्रश्नपत्रिका स्विकारू नये.
  - पहिल्या पृष्ठावर नमूद केल्याप्रमाणे प्रश्नपत्रिकेची एकूण पृष्ठे तसेच प्रश्नपत्रिकेतील एकूण प्रश्नांची संख्या पडताळून घ्यावी. पृष्ठे कमी असलेली/कमी प्रश्न असलेली/प्रश्नांचा चुकीचा क्रम असलेला किंवा इतर त्रुटी असलेला सदोष प्रश्नपत्रिका सुरुवातीच्या 5 मिनिटातच पर्यवेक्षकाला परत देऊन दुसरी प्रश्नपत्रिका मागवून घ्यावी. त्यानंतर प्रश्नपत्रिका बदलून मिळणार नाही तसेच वेळही वाढवून मिळणार नाही याची कृपया विद्यार्थ्यांनी नोंद घ्यावी.
  - वरीलप्रमाणे सर्व पडताळून पाहिल्यानंतरच प्रश्नपत्रिकेवर ओ.एम.आर. उत्तरपत्रिकेचा नंबर लिहावा.
- प्रत्येक प्रश्नासाठी (A), (B), (C) आणि (D) अशी चार विकल्प उत्तरे दिली आहेत. त्यातील योग्य उत्तराचा रकाना खाली दर्शविल्याप्रमाणे ठळकपणे काळ/निळ्व करावा.

**उदा. :** जर (C) हे योग्य उत्तर असेल तर.

**(A) (B) (C) (D)**
- या प्रश्नपत्रिकेतील प्रश्नांची उत्तरे **ओ.एम.आर. उत्तरपत्रिकेतच दर्शवावीत**. इतर ठिकाणी लिहिलेली उत्तरे तपासली जाणार नाहीत.
- आत दिलेल्या सूचना काळजीपूर्वक वाचाव्यात.
- प्रश्नपत्रिकेच्या शेवटी जोडलेल्या कोऱ्या पानावरच कच्चे काम करावे.
- जर आपण ओ.एम.आर. वर नमूद केलेल्या ठिकाणा व्यतिरीक्त इतर कोठेही नाव, आसन क्रमांक, फोन नंबर किंवा ओळख पटेल अशी कोणतीही खूण केलेली आढळून आल्यास अथवा असभ्य भाषेचा वापर किंवा इतर गैरमार्गाचा अवलंब केल्यास विद्यार्थ्यांला परीक्षेस अपात्र ठरविण्यात येईल.
- परीक्षा संपल्यानंतर विद्यार्थ्यांने मूळ ओ.एम.आर. उत्तरपत्रिका पर्यवेक्षकांकडे परत करणे आवश्यक आहे. तथापि, प्रश्नपत्रिका व ओ.एम.आर. उत्तरपत्रिकेची द्वितीय प्रत आपल्याबरोबर नेण्यास विद्यार्थ्यांना परवानगी आहे.
- फक्त निळ्व्या किंवा काळ्या बॉल पेनचाच वापर करावा.
- कॅलक्युलेटर किंवा लॉग टेबल वापरण्यास परवानगी नाही.
- चुकीच्या उत्तरासाठी गुण कपात केली जाणार नाही.

**APR - 32224/II—D**

## Physical Science Paper II

**Time Allowed : 120 Minutes]**

**[Maximum Marks : 200**

**Note :** This paper contains **Hundred (100)** multiple choice questions. Each question carrying **Two (2)** marks. Attempt *All* questions.

1. Which of the following transistor amplifier configuration is often used in impedance-matching application ?

- (A) The common-base amplifier
- (B) The emitter follower
- (C) The common-emitter amplifier
- (D) The common-source amplifier

2. For the following OP-amp circuit,  $R_1 = R_2 = R_3 = R_F = 1.0 \text{ k}\Omega$ , the output voltage  $V_{out}$  is :

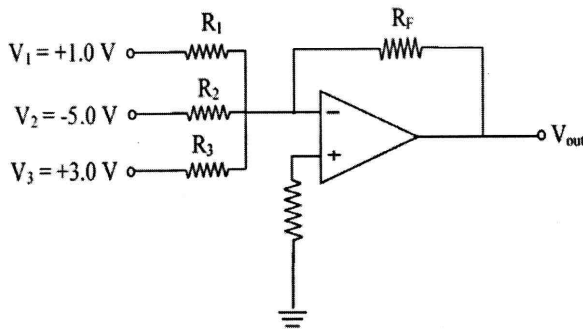

- (A) +1.0V
- (B) -1.0V
- (C) +0.5V
- (D) -0.5V

3. The following diode circuit acts as a :

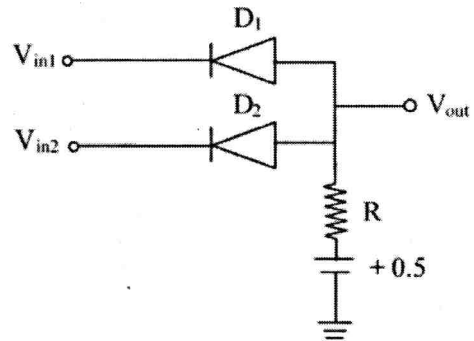

- (A) AND gate
- (B) OR gate
- (C) NAND gate
- (D) NOR gate

4. The binary output  $Y_3 Y_2 Y_1 Y_0$  of the following logic circuit for the inputs  $X_3 X_2 X_1 X_0 = 1 0 1 1$  is :

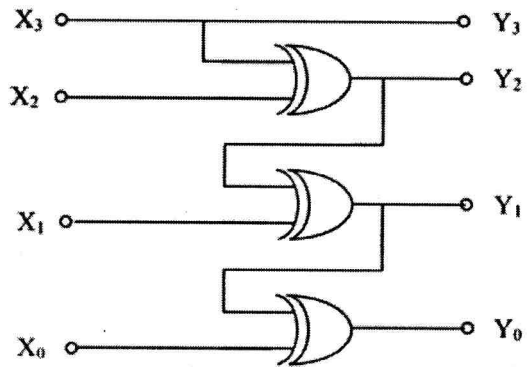

- (A) 1 1 0 1
- (B) 1 0 1 0
- (C) 1 1 1 1
- (D) 0 1 0 1

5. A four-bit ripple counter consists of flip-flops that each have a propagation delay from clock to Q output of 12 ns. For the counter of recycle from 1111 to 0000; it will take a total delay of :
- (A) 12 ns  
 (B) 24 ns  
 (C) 36 ns  
 (D) 48 ns
6. A sinusoidal input voltage  $V_{in} = V_0 \sin \omega t$  of frequency  $\omega$  is given as an input to the following circuit. If  $V_m$  is the peak value of the input voltage, the output voltage  $V_{out}$  is :

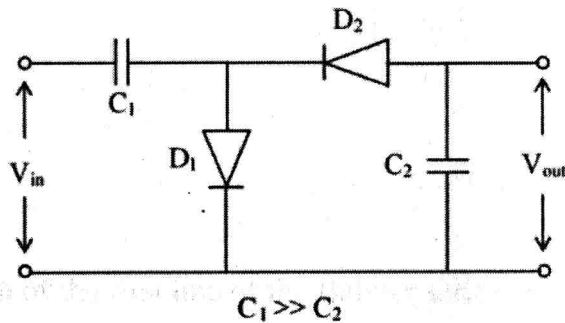

- (A)  $2 V_0 \sin \omega t$   
 (B)  $\sqrt{2} V_m$   
 (C)  $2 V_m$   
 (D)  $(V_m/2) \sin \omega t$

7. The modulation index of an AM wave is :
- (A)  $m = (V_{max} - V_{min}) / (V_{max} + V_{min})$   
 (B)  $m = (V_{max} + V_{min}) / (V_{max} - V_{min})$   
 (C)  $m = (V_{max} \times V_{min}) / (V_{max} + V_{min})$   
 (D)  $m = (V_{max} \times V_{min}) / (V_{max} - V_{min})$
8. A digital to analogue converter has 5.0 V full scale output voltage and an accuracy of  $\pm 0.2$ . The maximum error for any output voltage will be :
- (A) 5.0 mV  
 (B) 10.0 mV  
 (C) 20.0 mV  
 (D) 100 mV
9. A thermistor is suitable for :
- (A) High span but low sensitivity  
 (B) High span and high sensitivity  
 (C) Low span but high sensitivity  
 (D) Low span and low sensitivity

10. The error of an instrument is normally given as percentage of :
- (A) Measured value  
(B) Full scale value  
(C) Mean value  
(D) RMS value
11. If the wavelength of the first line of the Balmer series in the hydrogen spectrum is  $\lambda$ , then the wavelength of the first line of the Lyman series is :
- (A)  $(27/32)\lambda$   
(B)  $(27/5)\lambda$   
(C)  $(5/27)\lambda$   
(D)  $(32/27)\lambda$
12. The  $g_N$  value for  $F^{19}$  nucleus is 5.256. The resonance frequency when it is placed in a magnetic field of strength 1.0 T is (Given  $\mu_N = 5.0504 \times 10^{-27}$  J/T) :
- (A) 40 MHz  
(B) 4.0 MHz  
(C) 60 MHz  
(D) 0.60 MHz
13.  $Mn^{3+}$  ion has four 3d electrons. The spectroscopic term factor of this ion is :
- (A)  $^1D_2$   
(B)  $^4F_{3/2}$   
(C)  $^3F_{9/2}$   
(D)  $^5D_0$

14. The energy separation between two consecutive Stokes lines in Raman spectrum depends on :
- (A) Energy separation between vibrational levels in the excited state
- (B) Wavelength of the incident light
- (C) Energy separation between vibrational levels in the ground state
- (D) Intensity of the incident light
15. In a He-Ne laser, the laser transition takes place in :
- (A) Ne only
- (B) He only
- (C) Ne first and then in He
- (D) He first and then in Ne
16. If the ESR frequency for a free electron is 9000 MHz, then the magnetic field, at which the ESR spectrometer is working, will be (Given  $g = 2.0$  and  $\mu_B = 9.2732 \times 10^{-24}$  J/T) :
- (A) 600.5 mT
- (B) 321.5 mT
- (C) 400.0 mT
- (D) 60.50 mT
17. Light of wavelength  $1.5 \mu\text{m}$  incident on a material with a characteristic Raman frequency of  $20 \times 10^{12}$  Hz results in a Stokes-shifted line of wavelength :
- (A)  $1.47 \mu\text{m}$
- (B)  $1.57 \mu\text{m}$
- (C)  $1.67 \mu\text{m}$
- (D)  $1.77 \mu\text{m}$
18. Assuming that the L-S coupling scheme is valid, the number of permitted transitions from  ${}^2P_{3/2} \rightarrow {}^2S_{1/2}$  due to a weak magnetic field is :
- (A) 2
- (B) 4
- (C) 6
- (D) 10

19. A muon from cosmic rays is trapped by a proton to form a hydrogen-like atom. Given that a muon is approximately 200 times heavier than an electron, the longest wavelength of the spectral line (in analogy with the Lyman series) of such an atom will be :
- (A) 5.62 Å  
(B) 6.67 Å  
(C) 3.75 Å  
(D) 13.3 Å
20. An irradiated sample of MgO has a strong ESR line at 0.163 T when the ESR spectrometer is operating at 9.4 GHz. The  $g$  value of the ESR line of MgO will be :
- (A) 2.0  
(B) 2.205  
(C) 4.13  
(D) 3.020
21. The first Brillouin zone of FCC lattice is :
- (A) Rhombic dodecahedron  
(B) Truncated octahedron  
(C) Cube  
(D) Parallelepiped
22. The specific heat of bulk copper has the behaviour  $C_V \cong 4.6 \times 10^{-2} \times T^3$  Jmol<sup>-1</sup>K<sup>-1</sup> at low temperature. The Debye temperature of copper is found to be :
- (A) 2.48 K  
(B) 348 K  
(C) 448 K  
(D) 548 K

23. A linear diatomic chain consists of two atoms having masses 2 kg and 16 kg respectively. The extremum frequency of optical branch is :
- (A)  $\sqrt{2}$   
(B) 2  
(C)  $1/\sqrt{2}$   
(D) 1/2
24. The wavelength of the photon which will be required to break a Cooper pair in a superconductor like aluminium whose critical temperature is 1.2 K is :
- (A)  $2.5 \times 10^{-3}\text{m}$   
(B)  $3.4 \times 10^{-3}\text{m}$   
(C)  $4.4 \times 10^{-3}\text{m}$   
(D)  $5.4 \times 10^{-3}\text{m}$
25. In the Kronig-Penney model, if there exists no potential barrier, then :
- (A) There is periodic dependence of energy on wave vector  $\vec{k}$   
(B) Energy is not a continuous function of wave vector  $\vec{k}$   
(C) There are no forbidden energy regions  
(D) All values of energy are not allowed
26. Trivalent iron ion is characterized by the spectroscopic term  ${}^6\text{S}_{7/2}$ . Its effective magneton number is :
- (A) 2.83  
(B) 5.92  
(C) 3.87  
(D) 2.32



27. The ratio of the number of vacancies in equilibrium at 300 K in aluminium to that produced by rapid quenching at 800 K is (given that the enthalpy of formation of vacancy in Al is 68 kJ/mole and  $R = 8.314 \text{ kmol}^{-1}/\text{K}$ )
- (A)  $3.75 \times 10^{-8}$   
 (B)  $2.15 \times 10^{-10}$   
 (C)  $3.18 \times 10^{-10}$   
 (D)  $3.75 \times 10^{-10}$
28. The dispersion relation for a low density plasma is  $\omega^2 = \omega_0^2 + c^2 k^2$ , where  $\omega_0$  is the plasma frequency and  $c$  is the speed of light in free space. The relationship between the group velocity ( $V_g$ ) and phase velocity ( $V_p$ ) is :
- (A)  $V_p = V_g$   
 (B)  $V_p = (V_g)^{1/2}$   
 (C)  $V_p V_g = c^2$   
 (D)  $V_g = (V_p)^{1/2}$
29. In a BCC lattice with lattice constant ' $a$ ', the body-centered position from the origin is at a distance of :
- (A)  $\sqrt{2}a$   
 (B)  $\sqrt{\left(\frac{3}{2}\right)}a$   
 (C)  $\frac{\sqrt{3}}{2}a$   
 (D)  $\frac{\sqrt{3}}{4}a$
30. The chemical potential ( $\mu$ ) of a solid coincides with Fermi energy ( $E_F$ ) at absolute zero. At temperature  $T > 0$ , which of the following options is correct ?
- (A)  $\mu = E_F$   
 (B)  $\mu > E_F$   
 (C)  $\mu < E_F$   
 (D)  $\mu = 0$

31. A sample of silicon of thickness  $200 \mu\text{m}$  is doped with  $10^{23}$  phosphorus atoms per  $\text{m}^3$ . If the sample is kept in a magnetic field of  $0.2 \text{ Wb/m}^2$  and a current is passed through the sample, the Hall voltage produced is :
- (A)  $62.5 \mu\text{V}$   
 (B)  $-6.25 \mu\text{V}$   
 (C)  $+6.25 \mu\text{V}$   
 (D)  $-62.5 \mu\text{V}$
32. What is the binding energy of the nucleus for isobar  ${}^{64}_{29}\text{Cu}$  ?  
 [Given :  $M_n = 1.008665 \text{ amu}$ ,  $M_p = 1.007825 \text{ amu}$ ,  ${}^{64}_{29}\text{Cu} = 63.9298 \text{ amu}$ ]
- (A)  $450.20 \text{ MeV}$   
 (B)  $512.03 \text{ MeV}$   
 (C)  $556.18 \text{ MeV}$   
 (D)  $612.30 \text{ MeV}$
33. What is the maximum energy of  $\beta$ -particle emitted when  ${}^3_1\text{H}$  decays to  ${}^3_2\text{He}$  ?  
 [Given :  ${}^3_1\text{H} = 3.01605 \text{ amu}$ ,  ${}^3_2\text{He} = 3.01603 \text{ amu}$  ]
- (A)  $9.8 \text{ kev}$   
 (B)  $12.7 \text{ kev}$   
 (C)  $15.5 \text{ kev}$   
 (D)  $18.7 \text{ kev}$
34. The quark content of the subatomic particle  $K^0$  with strangeness  $S = +1$  and isospin  $I = 1/2$  is given by :
- (A)  $d\bar{s}$   
 (B)  $\bar{d}s$   
 (C)  $d\bar{d}$   
 (D)  $u\bar{u}$

35. The number of fissions per second in a 100 Mwatt nuclear reactor is :
- (A)  $3 \times 10^6$   
 (B)  $3 \times 10^{12}$   
 (C)  $3 \times 10^{18}$   
 (D)  $3 \times 10^{24}$
36. What is the energy of gamma rays emitted in the beta decay of  ${}_{13}^{28}\text{Al}$ ?  
 [Given :  $E_{\text{max}} = 2.86 \text{ MeV}$ ,  ${}_{13}^{28}\text{Al} = 27.981908 \text{ amu}$  and  ${}_{14}^{28}\text{Si} = 27.976929 \text{ amu}$ ]
- (A) 1.25 MeV  
 (B) 1.78 MeV  
 (C) 1.86 MeV  
 (D) 2.30 MeV
37. The reaction  $\Pi^+ + n \rightarrow \Pi^0 + \text{K}^+$  cannot be induced due to non-conservation of :
- (A) Isospin  
 (B) Baryon number  
 (C) Third component  
 (D) Strangeness
38. What spin-parity and isospin would the shell model predict for the ground states of  ${}_{6}^{13}\text{C}$  [Recall that the  $P_{3/2}$  shell lies below  $P_{1/2}$ ]
- (A)  $J^P = (3/2)^-, I = 3/2$   
 (B)  $J^P = (1/2)^-, I = 1/2$   
 (C)  $J^P = (1/2)^-, I = 1/2$   
 (D)  $J^P = (3/2)^-, I = 1/2$

39. The following nuclear reaction cannot be induced because



- (A) Q and B are conserved but  $I_3$  and L are not conserved
- (B) Q, B and L are conserved but  $I_3$  is not conserved
- (C) Q, B and  $I_3$  are conserved but L is not conserved
- (D) B,  $I_3$  and L are conserved but Q is not conserved

40. What are the appropriate values for the corresponding lifetimes of hadronic decay, electromagnetic decay and weak decay ?

- (A)  $10^{-9}$  sec,  $10^{-6}$  sec,  $10^{-3}$  sec
- (B)  $10^{-12}$  sec,  $10^{-9}$  sec,  $10^{-6}$  sec
- (C)  $10^{-15}$  sec,  $10^{-13}$  sec,  $10^{-6}$  sec
- (D)  $10^{-23}$  sec,  $10^{-18}$  sec,  $10^{-10}$  sec

41. For the differential equation

$$x^2 \frac{d^2 y}{dx^2} + x \frac{dy}{dx} + (x^2 - n^2)y = 0$$

Which of the following statements is true ?

- (A)  $x = 0$  and the point at infinity are regular singular points
- (B)  $x = 0$  is an ordinary point, while the point at infinity is a regular singular point.
- (C)  $x = 0$  is a regular singular point, while the point at infinity is an irregular singular point
- (D)  $x = 0$  is an ordinary point, while the point at infinity is singular.

42. The matrix  $\begin{pmatrix} 1 & 1 & 1 & 1 \\ 2 & 2 & 2 & 2 \\ 1 & 3 & 3 & 3 \\ 4 & 4 & 4 & 4 \end{pmatrix}$  has

rank :

(A) 1

(B) 2

(C) 3

(D) 4

43. Most generic eigenvalues of a  $3 \times 3$  traceless matrix with zero determinant are given as ( $a$  is some constant) :

(A) 0, 0, 0

(B) 0, 0,  $a$

(C)  $a, -a, 0$

(D)  $a, -2a, a$

44. Consider a differential equation

$$\left( \frac{d^4}{dx^4} + 2 \frac{d^2}{dx^2} \right) f(x) = g(x)$$

Let  $F(k)$  and  $G(k)$  be the Fourier transforms of  $f(x)$  and  $g(x)$  respectively. Then  $F(k)$  is :

(A)  $F(k) = (k^4 - 2k^2) G(k)$

(B)  $F(k) = \frac{G(k)}{(k^4 - 2k^2)}$

(C)  $F(k) = (k^4 + 2k^2) G(k)$

(D)  $F(k) = \frac{G(k)}{(k^4 - 2ik^2)}$

45. Laplace transform of  $(1 + \sin(2t))$  is :

(A)  $\frac{1}{s} + \frac{1}{s^2 + 1}$

(B)  $\frac{1}{s} + \frac{2}{s^2 + 4}$

(C)  $\frac{1}{s} + \frac{4s}{s^2 + 4}$

(D)  $1 + \frac{1}{s^2 + 4}$

46. The value of  $\int_C z \, dz$  over the contour C, where C is any open contour starting at  $z_1 = (-1, 0)$  and ending at  $z_2 = (0, 1)$  is equal to :

- (A) 0
- (B)  $\pi$
- (C) 2
- (D) 1

47. The value of the integral  $\int_C \frac{\sin z}{z} \, dz$  over the contour C, C given by  $|z| = 1$  and traversed counter-clockwise, is :

- (A)  $2\pi i$
- (B)  $\frac{2\pi i}{\sqrt{3}}$
- (C) 0
- (D)  $\frac{\pi}{\sqrt{3}}$

48. Mean is the same as variance for a :

- (A) Poisson distribution
- (B) Normal distribution
- (C) Uniform distribution
- (D) Binomial distribution

49. The Green's function for the following boundary value problem

$$\frac{d^2 y}{dx^2} = f(x) \quad \text{with boundary conditions : } y(0) = 0, y(1) = 1, \text{ is :}$$

$$(A) \quad G(x, x_0) = \begin{cases} x_0(x-1) & \text{for } 0 \leq x_0 \leq x \\ x(x_0-1) & \text{for } x \leq x_0 \leq 1 \end{cases}$$

$$(B) \quad G(x, x_0) = \begin{cases} x_0/(x-1) & \text{for } 0 \leq x_0 \leq x \\ x/(x_0-1) & \text{for } x \leq x_0 \leq 1 \end{cases}$$

$$(C) \quad G(x, x_0) = \begin{cases} (x_0-1)/x & \text{for } 0 \leq x_0 \leq x \\ (x-1)/x_0 & \text{for } x \leq x_0 \leq 1 \end{cases}$$

$$(D) \quad G(x, x_0) = \begin{cases} x_0(x+1) & \text{for } 0 \leq x_0 \leq x \\ x(x_0+1) & \text{for } x \leq x_0 \leq 1 \end{cases}$$

50. To find the roots of equation  $x^2 - 20 = 0$  using the Newton-Raphson method, the iterative formula for the successive trial root is :

$$(A) \quad x_{k+1} = \frac{x_k}{2} - \frac{10}{x_k}$$

$$(B) \quad x_{k+1} = -\frac{x_k}{2} + \frac{10}{x_k}$$

$$(C) \quad x_{k+1} = x_k - \frac{x_k}{20}$$

$$(D) \quad x_{k+1} = x_k - \frac{20}{x_k}$$

51. The order of magnitude of the error in estimating the value of the integral  $\int_0^1 (x^3 + 2x^2 + 4x + 9) dx$  numerically, using Simpson's 1/3rd method with a step size of 0.1 is :
- (A)  $10^{-4}$   
 (B)  $10^{-5}$   
 (C) 0  
 (D)  $10^{-3}$

52. A reservoir discharges water through holes with shutters at depth  $h$  and surface area  $A(h)$ . The values are given in the following table. If  $t$  denotes the time in minutes and the rate of fall of the water level is given by the equation  $\frac{dh}{dt} = -\frac{48h}{A}$ , what is the time taken in minutes for the water level to fall from 14 ft. to 10 ft. above the holes ?

h (in ft.)	A (in sq. ft.)
10	940
11	1078
12	1200
13	1352
14	1540

- (A) 8.41  
 (B) 2.63  
 (C) 5.48  
 (D) 6.06

53. Given that  $\alpha$  and  $\beta$  are complex numbers, which of the following sets of matrices forms a group under matrix multiplication ?

(A)  $\begin{pmatrix} \alpha & \beta \\ 0 & 0 \end{pmatrix}$

(B)  $\begin{pmatrix} 1 & \alpha \\ \beta & 1 \end{pmatrix}$  where  $\alpha\beta \neq 1$

(C)  $\begin{pmatrix} \alpha & \alpha^* \\ \beta & \beta^* \end{pmatrix}$  where  $\alpha\beta^*$  is real

(D)  $\begin{pmatrix} \alpha & \beta \\ -\beta^* & \alpha^* \end{pmatrix}$  where  $|\alpha|^2 +$

$|\beta|^2 = 1$

54. A uniform stick of mass  $m$  and length  $l$  is pivoted about a horizontal axis through its lower end at O (as shown in the figure). Initially, it is held vertically and is allowed to fall freely downwards (under the action of gravity, with no air resistance). Its angular velocity at the instant when it makes an angle of  $60^\circ$  with the vertical is (given that the moment of inertial  $I = ml^2/3$  and  $g$  is acceleration due to gravity) :

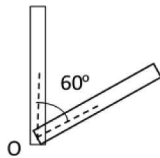

- (A)  $\sqrt{3g/2l}$   
 (B)  $\sqrt{2g/3l}$   
 (C)  $\sqrt{2g/l}$   
 (D)  $\sqrt{g/2l}$
55. The velocities of a satellite (orbiting around earth) at perigee and apogee points are 25 km/s and 10 km/s respectively. If the perigee distance from the centre of the earth is 10000 km, what is the apogee distance ?  
 (A) 25000 km  
 (B) 20000 km  
 (C) 2500 km  
 (D) 2000 km

56. Laplace-Runge Lenz vector  $\vec{A}$  is defined as :

$$\vec{A} = \vec{p} \times \vec{l} - \frac{\mu k \vec{r}}{r}$$

where  $\vec{l}$  is angular momentum vector,  $\vec{p}$  is linear momentum vector,  $\mu$  is the reduced mass, and  $\vec{r}$  is the radius vector. If  $\vec{A}$  is conserved for motion in  $-k/r$  potential, then the direction of  $\vec{A}$  in an elliptical orbit is :

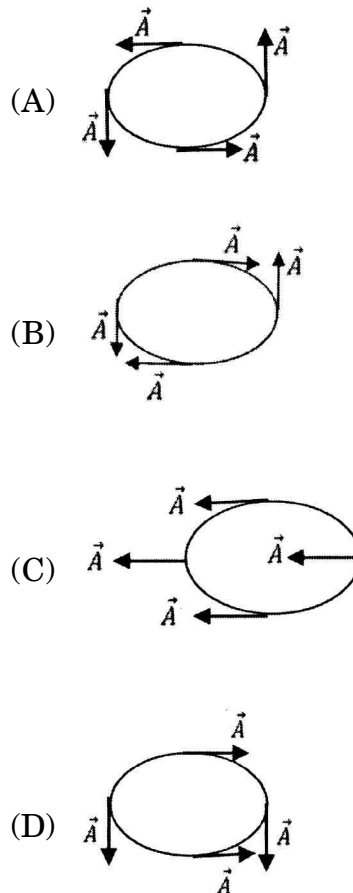



57. The plane of oscillation of a Foucault pendulum rotates :

- (A)  $15^\circ$  per hour at the equator
- (B)  $15^\circ$  per hour at the pole
- (C)  $7.5^\circ$  per hour at latitude  $60^\circ$
- (D)  $30^\circ$  per hour at latitude  $60^\circ$

58. A bead of mass  $m$  slides on a smooth massless rod. The rod is rotating about one end in X-Y plane with uniform angular velocity  $\omega$  (as shown in the figure). The Lagrangian of the system is given as :

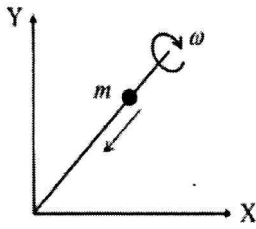

- (A)  $L = \frac{1}{2} mr^2 \dot{\theta}^2 - mgr \sin \theta$
- (B)  $L = \frac{1}{2} mr^2 \dot{\theta}^2 - mgr \cos \theta$
- (C)  $L = \frac{1}{2} m(\dot{r}^2 + r^2 \dot{\theta}^2) - mgr \sin \theta$
- (D)  $L = \frac{1}{2} m(\dot{r}^2 + r^2 \dot{\theta}^2) + mgr \cos \theta$

59. In the case of two coupled identical pendulums, in general :

- (A) The potential energy is a homogeneous quadratic function, when expressed in terms of actual displacements
- (B) The potential energy is a homogeneous quadratic function, when expressed in terms of normal coordinates
- (C) The potential energy is not a homogeneous quadratic function, when expressed in terms of actual coordinates
- (D) The potential energy is a homogeneous quadratic function, when expressed in terms of actual coordinates and not a homogeneous quadratic function, when expressed in terms of normal coordinates

60. Two frames S and S' are in relative motion. The frame S' is moving with speed  $c/2$ , where  $c$  is the speed of light. In the frame S two events occur at  $(x_1, t_1)$  and  $(x_2, t_2)$ . In the frame S', these events occur simultaneously. Then the value of  $(x_2 - x_1)/(t_2 - t_1)$  is :
- (A)  $c/2$   
 (B)  $2c$   
 (C)  $c/4$   
 (D)  $4c$
61. The number of degrees of freedom of a system, comprising of an ant moving on the surface of a sphere, which is rolling on a smooth horizontal surface, is :
- (A) 3  
 (B) 6  
 (C) 5  
 (D) 4

62. A particle is projected at an angle  $\alpha$  with respect to the horizontal axis. Its path, observed in a frame of reference moving with a velocity equal to the horizontal component of its velocity, will be :
- (A) a straight line making an angle  $\alpha$  with the horizontal  
 (B) a horizontal straight line  
 (C) a vertical straight line  
 (D) a straight line making an angle  $\alpha$  with the vertical
63. A particle of mass  $m$  is falling freely vertically in a uniform gravitational field. The Hamilton-Jacobi equation describing its motion is :
- (A)  $\frac{1}{2m} \left[ \left( \frac{\partial s}{\partial x} \right)^2 + \left( \frac{\partial s}{\partial y} \right)^2 \right] + mgz + \frac{\partial s}{\partial t} = 0$
- (B)  $\frac{1}{2m} \left[ \left( \frac{\partial s}{\partial x} \right)^2 + \left( \frac{\partial s}{\partial y} \right)^2 + \left( \frac{\partial s}{\partial z} \right)^2 \right] + mgz + \frac{\partial s}{\partial t} = 0$
- (C)  $\frac{1}{2m} \left[ \left( \frac{\partial s}{\partial z} \right)^2 \right] + mgz + \frac{\partial s}{\partial t} = 0$
- (D)  $\frac{1}{2m} \left[ \left( \frac{\partial s}{\partial z} \right)^2 \right] + mgz = 0$

64. The condition for generating function  $F$ , defining canonical transformations, is that the differential  $dF$  is exact. Which of the following relations does not satisfy this condition ?
- (A)  $dF = \sum_i p_i \delta q_i - \sum_i P_i \delta Q_i$   
 (B)  $dF = \sum_i q_i \delta p_i + \sum_i Q_i \delta P_i$   
 (C)  $dF = \sum_i p_i \delta q_i + \sum_i Q_i \delta P_i$   
 (D)  $dF = \sum_i q_i \delta p_i + \sum_i P_i \delta Q_i$
65. If the magnetic monopole existed, then which of the following Maxwell's equations will be modified ?
- (A)  $\nabla \cdot \vec{D} = \rho$   
 (B)  $\nabla \cdot \vec{B} = 0$   
 (C)  $\nabla \times \vec{E} = -\partial \vec{B} / \partial t$   
 (D)  $\nabla \times \vec{H} = \vec{J} + \partial \vec{D} / \partial t$
66. A conducting sphere of radius  $R$  has charge  $+Q$  on its surface. If the charge on the surface is doubled and its radius is halved, the energy associated with the electric field will :
- (A) Increase four times  
 (B) Remain the same  
 (C) Increase eight times  
 (D) Decrease four times
67. The ratio of electric field vector  $\vec{E}$  and magnetic field vector  $\vec{H}$  has the dimension of :
- (A) Inductance  
 (B) Capacitance  
 (C) Resistance  
 (D) Product of inductance and capacitance
68. The value of Poynting vector at the surface of a long cylindrical wire of radius  $R$  and length  $L$  carrying a current  $I$  when its ends are kept at a potential difference of  $V$  is :
- (A) Zero  
 (B)  $(VI)/(2\pi R^2 + 2\pi RL)$   
 (C)  $(VI)/(\pi R^2 L)$   
 (D)  $(VI)/(2\pi RL)$
69. For a good conductor skin depth varies inversely with ..... power of frequency.
- (A) First  
 (B) Second  
 (C) Half  
 (D) Third

70. A magnetic dipole of dipole moment ( $\vec{m}$ ) is placed in a non-uniform magnetic field  $\vec{B}$ . If the position vector of the dipole is  $\vec{r}$ , the torque acting on the dipole about the origin is :
- (A)  $\vec{r} \times (\vec{m} \times \vec{B})$   
 (B)  $\vec{r} \times \vec{\nabla}(\vec{m} \cdot \vec{B})$   
 (C)  $\vec{m} \times \vec{B}$   
 (D)  $\vec{m} \times \vec{B} + \vec{r} \times \vec{\nabla}(\vec{m} \cdot \vec{B})$
71. A 6 cm  $\times$  4 cm rectangular wave guide is filled with dielectric of refractive index 1.25. The range of frequencies over which single mode operation will occur is :
- (A) 2.24 GHz  $< f <$  3.33 GHz  
 (B) 2 GHz  $< f <$  3 GHz  
 (C) 4.4 GHz  $< f <$  70 GHz  
 (D) 4 GHz  $< f <$  6 GHz
72. In Lorentz gauge, Lorentz condition is given by :
- (A)  $\vec{\nabla} \cdot \vec{A} - \frac{1}{c} \frac{\partial \phi}{\partial t} = 0$   
 (B)  $\vec{\nabla} \cdot \vec{A} + \frac{1}{c} \frac{\partial \phi}{\partial t} = 0$   
 (C)  $-\vec{\nabla} \cdot \vec{A} + \frac{1}{4\pi c} \frac{\partial \phi}{\partial t} = 0$   
 (D)  $-\vec{\nabla} \cdot \vec{A} - \frac{1}{4\pi c^2} \frac{\partial \phi}{\partial t} = 0$
73. The SI unit of the quantity  $\frac{|\mathbf{E}|}{|\mathbf{B}|}$  is :
- (A) s/m  
 (B) m/s  
 (C)  $c^2\text{m/s}$   
 (D)  $c^2\text{m}^2/\text{s}$
74. Consider an ideal rectangular wave guide (dimension  $\sim$  4.0 cm  $\times$  2.0 cm) with vacuum inside. Plane monochromatic electromagnetic radiation having a wavelength of 6 cm is introduced in this wave guide. The radiation propagates inside the wave guide in mode :
- (A) Only  $\text{TE}_{10}$   
 (B) Only  $\text{TM}_{10}$   
 (C) Both  $\text{TE}_{10}$  and  $\text{TM}_{10}$   
 (D) Both  $\text{TE}_{10}$  and only  $\text{TE}_{01}$

75. The ratio of skin depths of Copper for the He-Ne laser ( $\lambda = 6328 \text{ \AA}$ ) to that for Nd : YAG laser ( $\lambda = 1.06 \text{ }\mu\text{m}$ ) is :
- (A) 0.597  
(B) 0.95  
(C) 1.294  
(D) 1.675
76. A particle of mass  $m$  is confined in a three-dimensional rectangular box of sides  $L$ ,  $L/2$  and  $2L$ . The third and fourth excited state energies and their degeneracies (written in brackets) are :
- (A)  $33/8 \pi^2 h^2 / mL^2$  (1),  $9/2 \pi^2 h^2 / mL^2$  (2)  
(B)  $33/8 \pi^2 h^2 / mL^2$  (1),  $35/8 \pi^2 h^2 / mL^2$  (1)  
(C)  $35/8 \pi^2 h^2 / mL^2$  (1),  $9/2 \pi^2 h^2 / mL^2$  (2)  
(D)  $35/8 \pi^2 h^2 / mL^2$  (1),  $9/2 \pi^2 h^2 / mL^2$  (1)
77.  $\psi(x, y) = \exp[|\sin(x - y)|] + (x - y)^2 / 2 + 3$  is :
- (A) symmetric under interchanged of  $x$  and  $y$ .  
(B) antisymmetric under interchanged  $x$  and  $y$ .  
(C) neither symmetric nor antisymmetric under the interchange of  $x$  and  $y$   
(D) both symmetric and antisymmetric under the interchange of  $x$  and  $y$  respectively
78. A quantum particle is incident on a potential barrier. The particle has incident energy that is less than the height of the potential barrier. When the particle penetrates the barrier, its wave function is :
- (A) Exponentially increasing  
(B) Exponentially decreasing  
(C) Oscillatory  
(D) A positive constant

79. Eigenvalues of the sum of two operators is the sum of the eigenvalues if :
- (A) The operators are Hermitian
- (B) The operators have diagonalizable commuting matrices
- (C) The operators are unitary
- (D) The operators are anti-Hermitian
80. If H is a Hermitian operator, the following is “always” true :
- (A) H has real diagonal matrix elements
- (B) H has positive diagonal matrix elements
- (C) H has imaginary off-diagonal matrix elements
- (D) H has a trace equal to zero
81. Using the normalized trial wave function  $\psi(x) = \left(\frac{2b}{\pi}\right)^{1/4} e^{-bx^2}$ , an upper bound for the ground state energy of a one-dimensional harmonic oscillator, oscillating with frequency  $\omega$ , is :
- (A)  $3/2 \hbar\omega$
- (B)  $\frac{1}{2} \hbar\omega$
- (C)  $\frac{3}{4} \hbar\omega$
- (D)  $\hbar\omega$
82. The commutator of the orbital angular momentum operators  $[L_+, L_-]$ , where  $L_{\pm} = L_x \pm iL_y$  is :
- (A) 0
- (B)  $2 \hbar L_x$
- (C)  $2 \hbar L_y$
- (D)  $2 \hbar L_z$

83. Consider a particle of mass  $m$  in a one-dimensional box of length  $L$ . A time-independent perturbation  $H_1 = \alpha \delta(x - L/2)$  is applied to the system. The first order correction to the ground state energy is :

- (A)  $\pi^2 \hbar^2 \alpha / (2 mL^2)$   
 (B) 0  
 (C)  $2\alpha/L$   
 (D)  $L/\alpha$

84. Using WKB approximation, the transmission probability through a parabolic barrier :

$$V(x) = \begin{cases} V_0 \left(1 - \frac{x^2}{a^2}\right) & \text{for } |x| < a \\ 0 & \text{for } |x| > a \end{cases} \text{ is :}$$

- (A)  $\exp \left[ \frac{\pi}{2} \sqrt{\frac{2mV_0 a^2}{\hbar^2}} \left(1 - \frac{E}{V_0}\right) \right]$   
 (B)  $\exp \left[ -\pi \sqrt{\frac{2mV_0 a^2}{\hbar^2}} \left(1 - \frac{E}{V_0}\right) \right]$   
 (C)  $\exp \left[ -\pi \sqrt{\frac{2mV_0 a^2}{\hbar^2}} \left(\frac{E}{V_0} - 1\right) \right]$   
 (D)  $\exp \left[ -\frac{\pi}{2} \sqrt{\frac{2mV_0 a^2}{\hbar^2}} \left(\frac{E}{V_0} - 1\right) \right]$

85. Validity of first-Born approximation for central force potential is :

- (A) Independent of incident energy and scattering potential  
 (B) For strong scattering potential weak incident energy  
 (C) For large incident energy and weak scattering potential  
 (D) For any central force potential

86. Spin-orbit coupling leads to :

- (A) Normal Zeeman effect  
 (B) Anomalous Zeeman effect  
 (C) Stark effect  
 (D) Hyperfine splitting

87. Which of the following statements is *not* correct ?

- (A) In the presence of spin-orbit coupling, the Hamiltonian does not commute with  $\bar{L}$  and  $\bar{S}$  operators  
 (B) Even in presence of spin-orbit coupling, the Hamiltonian commutes with  $\bar{L}^2$ ,  $\bar{S}^2$  and  $\bar{J}$  operators  
 (C) The spin-orbit interaction for an electron is described by  $H_{so} = (e^2 / 8\pi \epsilon_0) 1/(m^2 c^2 r^3) \bar{S} \cdot \bar{L}$ .  
 (D) In the presence of spin-orbit interaction, the physical quantities measured by  $\bar{L}^2$ ,  $\bar{S}^2$  and  $\bar{J}$  are not conserved.

88. The differential scattering cross-section  $\frac{d\sigma(\theta)}{d\Omega}$ , within the first Born approximation, for the central potential  $V(r) = \beta/r e^{-\mu r}$ , where  $\beta$  and  $\mu$  are positive constants has the dependence on scattering angle  $\theta$  as (A is constant) :
- (A)  $(A^2 + \sin^2 \theta/2)$   
 (B)  $(A^2 + \sin^2 \theta/2)^{-1}$   
 (C)  $(A^2 + \sin^2 \theta/2)^{-2}$   
 (D)  $(A^2 + \sin^2 \theta/2)^2$
89. Consider a random walk on a two-dimensional triangular lattice. The probability of taking any of the six possible steps is same. What is the probability that the walker returns to the starting position after taking exactly three steps ?
- (A)  $1/18$   
 (B)  $1/216$   
 (C)  $1/36$   
 (D)  $1/12$
90. An ideal monoatomic gas is compressed (no heat is added or removed in the process) so that its volume is halved. The ratio of the new pressure to the original pressure is :
- (A)  $\approx 3$   
 (B)  $\approx 9$   
 (C)  $\approx 12$   
 (D)  $\approx 15$
91. If a thermodynamic system has  $N$  particles at temperature  $T$ , then the fluctuation in average energy is proportional to :
- (A)  $1/N$   
 (B)  $1/\sqrt{N}$   
 (C)  $1/(3\sqrt{N})$   
 (D)  $N$



92. If the temperature  $T$  of photon gas in equilibrium in a radiation cavity is doubled, the equilibrium number of photons will increase by the factor of :
- (A) 2  
(B) 6  
(C) 8  
(D) 9
93. The volume of a perfect gas is doubled, the number of atoms  $N$  and the energy  $E$  being held constant, the change in entropy will be :
- (A)  $Nk \ln V$   
(B)  $2Nk \ln V$   
(C)  $Nk \ln 2$   
(D)  $\frac{1}{2} Nk \ln (2V)$
94. In adiabatic expansion of a system in which temperature changes from  $T_1$  to  $T_2$  the entropy :
- (A) will increase  
(B) will decrease  
(C) will remain unchanged  
(D) may increase or decrease depending on the ratio of  $T_1/T_2$
95. A Carnot cycle operates as a heat engine between two bodies of equal capacity until their temperatures become equal. If the initial temperatures of the bodies are  $T_1$  and  $T_2$  and  $T_1 > T_2$ , their common final temperature will be
- (A)  $\sqrt{T_1 T_2}$   
(B)  $2T_1 T_2 / (T_1 + T_2)$   
(C)  $(T_1 + T_2) / 2$   
(D) 0
96. The difference between fermions and bosons is that bosons do not obey :
- (A) Aufbau principle  
(B) Pauli exclusion principle  
(C) Hund's rule of maximum multiplicity  
(D) Heisenberg's uncertainty principle

97. If the system under consideration is in contact with both a heat reservoir and a particle reservoir, then the ensemble is :

- (A) Canonical
- (B) Microcanonical
- (C) Grandcanonical
- (D) Isobaric–isothermal

98. Average energy of a Planck's oscillator of frequency  $\nu$  is :

- (A)  $E = \hbar\nu$
- (B)  $E = n\hbar\nu$
- (C)  $E = \hbar\nu / (e^{\hbar\nu/kT} - 1)$
- (D)  $E = mc^2$

99. Knowing the fractional population of a two level system in thermal equilibrium at temperature  $T$  in a magnetic field  $\vec{B}$ , the magnetic moment is proportional to :

- (A) The difference between the population of the two states.
- (B) The sum of the population of the two states
- (C) Product of the population of the two states
- (D) Ratio of the population of the two states

100. The partition function of a two-level system described by the Hamiltonian

$$H = \begin{pmatrix} -\gamma & -\delta \\ -\delta & -\gamma \end{pmatrix} \text{ is :}$$

- (A)  $2 \cosh(\beta\sqrt{\gamma^2 + \delta^2})$
- (B)  $2 \sinh(\beta\sqrt{\gamma^2 + \delta^2})$
- (C)  $\frac{1}{2} \left\{ \cosh(\beta\sqrt{\gamma^2 + \delta^2}) + \sinh(\beta\sqrt{\gamma^2 + \delta^2}) \right\}$
- (D)  $\frac{1}{2} \left\{ \cosh(\beta\sqrt{\gamma^2 + \delta^2}) - \sinh(\beta\sqrt{\gamma^2 + \delta^2}) \right\}$

**APR - 32224/II—D**

**ROUGH WORK**

**APR - 32224/II—D**

**ROUGH WORK**