

Test Booklet Code & Serial No.

प्रश्नपत्रिका कोड व क्रमांक

**Paper-II**

**ELECTRONIC SCIENCE**

**C**

**Signature and Name of Invigilator**

Seat No.

--	--	--	--	--	--	--	--	--	--

1. (Signature) .....

(In figures as in Admit Card)

(Name) .....

Seat No. ....

(In words)

2. (Signature) .....

(Name) .....

OMR Sheet No.

--	--	--	--	--	--	--	--	--	--

**MAR - 38223**

(To be filled by the Candidate)

**Time Allowed : 2 Hours]**

**[Maximum Marks : 200**

**Number of Pages in this Booklet : 32**

**Number of Questions in this Booklet : 100**

**Instructions for the Candidates**

- Write your Seat No. and OMR Sheet No. in the space provided on the top of this page.
- This paper consists of **100** objective type questions. Each question will carry *two* marks. *All* questions of Paper II will be compulsory.
- At the commencement of examination, the question booklet will be given to the student. In the first 5 minutes, you are requested to open the booklet and compulsorily examine it as follows :
  - To have access to the Question Booklet, tear off the paper seal on the edge of this cover page. Do not accept a booklet without sticker-seal or open booklet.
  - Tally the number of pages and number of questions in the booklet with the information printed on the cover page. Faulty booklets due to missing pages/questions or questions repeated or not in serial order or any other discrepancy should not be accepted and correct booklet should be obtained from the invigilator within the period of 5 minutes. Afterwards, neither the Question Booklet will be replaced nor any extra time will be given. The same may please be noted.
  - After this verification is over, the OMR Sheet Number should be entered on this Test Booklet.
- Each question has four alternative responses marked (A), (B), (C) and (D). You have to darken the circle as indicated below on the correct response against each item.  
**Example :** where (C) is the correct response.  

<input type="radio"/>	<input type="radio"/>	<input checked="" type="radio"/>	<input type="radio"/>
A	B	C	D
- Your responses to the items are to be indicated in the **OMR Sheet given inside the Booklet only**. If you mark at any place other than in the circle in the OMR Sheet, it will not be evaluated.
- Read instructions given inside carefully.
- Rough Work is to be done at the end of this booklet.
- If you write your Name, Seat Number, Phone Number or put any mark on any part of the OMR Sheet, except for the space allotted for the relevant entries, which may disclose your identity, or use abusive language or employ any other unfair means, you will render yourself liable to disqualification.
- You have to return original OMR Sheet to the invigilator at the end of the examination compulsorily and must not carry it with you outside the Examination Hall. You are, however, allowed to carry the Test Booklet and duplicate copy of OMR Sheet on conclusion of examination.
- Use only Blue/Black Ball point pen.
- Use of any calculator or log table, etc., is prohibited.
- There is no negative marking for incorrect answers.

**विद्यार्थ्यांसाठी महत्वाच्या सूचना**

- परीक्षार्थींनी आपला आसन क्रमांक या पृष्ठावरील वरच्या कोपऱ्यात लिहावा. तसेच आपणांस दिलेल्या उत्तरपत्रिकेचा क्रमांक त्याखाली लिहावा.
- सदर प्रश्नपत्रिकेत **100** बहुपर्यायी प्रश्न आहेत. प्रत्येक प्रश्नास **दोन** गुण आहेत. या प्रश्नपत्रिकेतील **सर्व** प्रश्न सोडविणे अनिवार्य आहे.
- परीक्षा सुरू झाल्यावर विद्यार्थ्यांला प्रश्नपत्रिका दिली जाईल. सुरुवातीच्या 5 मिनिटांमध्ये आपण सदर प्रश्नपत्रिका उघडून खालील बाबी अवश्य तपासून घ्याव्यात.
  - प्रश्नपत्रिका उघडण्यासाठी प्रश्नपत्रिकेवर लावलेले सील उघडावे. सील नसलेली किंवा सील उघडलेली प्रश्नपत्रिका स्वीकारू नये.
  - पहिल्या पृष्ठावर नमूद केल्याप्रमाणे प्रश्नपत्रिकेची एकूण पृष्ठे तसेच प्रश्नपत्रिकेतील एकूण प्रश्नांची संख्या पडताळून घ्यावी. पृष्ठे कमी असलेली/कमी प्रश्न असलेली/प्रश्नांचा चुकीचा क्रम असलेली किंवा इतर त्रुटी असलेली सदोष प्रश्नपत्रिका सुरुवातीच्या 5 मिनिटांतच पर्यवेक्षकाला परत देऊन दुसरी प्रश्नपत्रिका मागवून घ्यावी. त्यानंतर प्रश्नपत्रिका बदलून मिळणार नाही तसेच वेळही वाढवून मिळणार नाही याची कृपया विद्यार्थ्यांनी नोंद घ्यावी.
  - वरीलप्रमाणे सर्व पडताळून पाहिल्यानंतरच प्रश्नपत्रिकेवर ओ.एम.आर. उत्तरपत्रिकेचा नंबर लिहावा.
- प्रत्येक प्रश्नासाठी (A), (B), (C) आणि (D) अशी चार विकल्प उत्तरे दिली आहेत. त्यातील योग्य उत्तराचा रकाना खाली दर्शविल्याप्रमाणे ठळकपणे काळा/निळ्या करावा.  
**उदा. :** जर (C) हे योग्य उत्तर असेल तर.  

<input type="radio"/>	<input type="radio"/>	<input checked="" type="radio"/>	<input type="radio"/>
A	B	C	D
- या प्रश्नपत्रिकेतील प्रश्नांची उत्तरे ओ.एम.आर. उत्तरपत्रिकेतच दर्शावावीत. इतर ठिकाणी लिहिलेली उत्तरे तपासली जाणार नाहीत.
- आत दिलेल्या सूचना काळजीपूर्वक वाचाव्यात.
- प्रश्नपत्रिकेच्या शेवटी जोडलेल्या कोऱ्या पानावरच कच्चे काम करावे.
- जर आपण ओ.एम.आर. वर नमूद केलेल्या ठिकाणाव्यतिरिक्त इतर कोठेही नाव, आसन क्रमांक, फोन नंबर किंवा ओळख पटेल अशी कोणतीही खूण केलेली आढळून आल्यास अथवा असभ्य भाषेचा वापर किंवा इतर गैरमार्गांचा अवलंब केल्यास विद्यार्थ्यांला परीक्षेस अपात्र ठरविण्यात येईल.
- परीक्षा संपल्यानंतर विद्यार्थ्यांने मूळ ओ.एम.आर. उत्तरपत्रिका पर्यवेक्षकांकडे परत करणे आवश्यक आहे. तथापि, प्रश्नपत्रिका व ओ.एम.आर. उत्तरपत्रिकेची द्वितीय प्रत आपल्याबरोबर नेण्यास विद्यार्थ्यांना परवानगी आहे.
- फक्त निळ्या किंवा काळ्या बॉल पेनचाच वापर करावा.
- कॅलक्युलेटर किंवा लॉग टेबल वापरण्यास परवानगी नाही.
- चुकीच्या उत्तरासाठी गुण कपात केली जाणार नाही.

**MAR - 38223/II—C**

## Electronic Science Paper II

**Time Allowed : 120 Minutes]**

**[Maximum Marks : 200**

**Note :** This Paper contains **Hundred (100)** multiple choice questions. Each question carrying **Two (2)** marks. Attempt *All* questions.

- |  |  |
|--|--|
| <p>1. After reset, SP register in 8051 is initialized to address .....</p> <p>(A) 8 H</p> <p>(B) 9 H</p> <p>(C) 7 H</p> <p>(D) 6 H</p> <p>2. What is the address range of SFR Register bank ?</p> <p>(A) 00H – 77H</p> <p>(B) 40H – 80H</p> <p>(C) 80H – 7FH</p> <p>(D) 80H – FFH</p> <p>3. If the ..... pin is ....., then we have the option of using the ..... ROM or EPROM together with ..... memory and devices.</p> <p>(A) <math>\overline{EA}</math>, high, internal, external</p> <p>(B) <math>\overline{EA}</math>, low, internal, external</p> <p>(C) <math>\overline{EA}</math>, high, external, internal</p> <p>(D) <math>\overline{EA}</math>, low, external, internal</p> | <p>4. What is the function of watchdog timer ?</p> <p>(A) The watchdog timer is an external timer that resets the system if the software fails to operate properly</p> <p>(B) The watchdog timer is an internal timer that sets the system if the software fails to operate properly</p> <p>(C) The watchdog timer is an internal timer that resets the system if the software fails to operate properly</p> <p>(D) Maintain log of execution</p> <p>5. Which of the following is of bit operations ?</p> <p>(i) SP</p> <p>(ii) P<sub>2</sub></p> <p>(iii) TMOD</p> <p>(iv) SBUF</p> <p>(v) IP</p> <p>(A) (ii) and (v) only</p> <p>(B) (ii), (iv), (v) only</p> <p>(C) (i), (v) only</p> <p>(D) (iii), (ii) only</p> |
|--|--|

6. Pipelining is implemented in 8086 with :
- (A) Segmented addressing
  - (B) Queue register in BIU which is LIFO
  - (C) Queue register in BIU which is FIFO
  - (D) Direct memory access
7. In 8086 which of the following is *not* true ?
- (A) Pipelining is implemented
  - (B) Segmented addressing is used
  - (C) Co-processor is interfaced in minimum mode
  - (D) Consists of Execution unit and Bus interface unit
8. What is the *correct* sequence of actions while interfacing an ADC with microprocessor ?
- (i) Data ready
  - (ii) Address enable
  - (iii) End of conversion
  - (iv) Start of conversion
- (A) (iv), (iii), (ii), (i)
  - (B) (ii), (iv), (iii), (i)
  - (C) (ii), (iii), (i), (iv)
  - (D) (iii), (ii), (i), (iv)

9. Match List I with List II and select the *correct* answer using the codes given below :

**List I**

- (a) TCON
- (b) SBUF
- (c) TMOD
- (d) PSW
- (e) PCON

**List II**

- (i) contains status information
- (ii) timer/counter control register
- (iii) idle bit, power down bit
- (iv) serial data buffer for  $T_x$  and  $R_x$
- (v) timer/counter modes of operation

**Codes :**

- (a) (b) (c) (d) (e)
- (A) (ii) (iv) (v) (i) (iii)
- (B) (i) (v) (iv) (iii) (ii)
- (C) (v) (iii) (ii) (iv) (i)
- (D) (iii) (ii) (i) (v) (iv)

10. **Assertion (A) :**

Chip select is a signal which allows multiple chips to be connected to the database.

**Reason (R) :**

The chip select enables the pins of the chip to make transitions between connected and high impedance states.

- (A) Both (A) and (R) are true and (R) is the correct explanation of (A)
- (B) Both (A) and (R) are true but (R) is not the correct explanation of (A)
- (C) (A) is true but (R) is false
- (D) (A) is false but (R) is true

## 11. Hierarchy of system design is :

- (A) System level, register transfer level, logic gate level, circuit level, physical level
- (B) Physical level, register transfer level, system level, logic gate level, circuit level
- (C) System level, circuit level, register transfer level, logic gate level, physical level
- (D) Logic gate level, system level, register transfer level, circuit level, physical level

## 12. The convolution of

$$x(m) = h(n) = \underset{\uparrow}{(1, 2, -1)}$$

will be :

- (A) {1, 4, 2, -4, 1}
- (B) {1, 4, 4, 2, 1}
- (C) {1, 4, 6, 4, 1}
- (D) {1, 4, 1}

13. Which factor does not affect CMOS loading ?

- (A) Charging time associated with output resistance of driving gate
- (B) Discharging time associated with the output resistance of driving gate
- (C) Output capacitance of the load gate
- (D) Input capacitance of the load gate

14. **Assertion (A) :**

A stick diagram is an easy method to create schematic circuit of a logic gate.

**Reason (R) :**

The stick diagram uses 'sticks' or lines to represent the devices and conductors.

- (A) Both (A) and (R) are true and (R) is the correct explanation of (A)
- (B) Both (A) and (R) are true but (R) is not the correct explanation of (A)
- (C) (A) is false but (R) is true
- (D) (A) and (R) both are false

15. Match List I with List II and select the correct answer using the codes given below :

**List I**

- (a) Chemical analysis
- (b) Structural characteristics
- (c) Topology
- (d) Electrical characteristics

**List II**

- (i) Probe station
- (ii) SEM
- (iii) XRD
- (iv) EDAX

**Codes :**

- (a) (b) (c) (d)
- (A) (i) (ii) (iv) (iii)
- (B) (iv) (ii) (i) (iii)
- (C) (iv) (iii) (ii) (i)
- (D) (iii) (i) (ii) (iv)

16. Positive photo resists are used more than negative photo resists because :
- (A) Negative photo resists are more resistive to light, but their photolithographic resolution is not as high as that of the positive photo resists
  - (B) Positive photo resists are more sensitive to light, but their photolithographic resolution is not as high as that of negative photo resists
  - (C) Negative photo resists are less sensitive to light
  - (D) Positive photo resists are less sensitive to light
17. Which is used for the inter-connection ?
- (A) Boron
  - (B) Oxygen
  - (C) Aluminium
  - (D) Silicon
18. One can get information on chemical composition of samples using :
- (A) EDAX
  - (B) TEM
  - (C) SEM only
  - (D) XRD
19. The device which moves charge between capacitive bins for creating image pixels is popularly known as :
- (A) Charge Coupled device
  - (B) Capacitive Cellular Device
  - (C) Charge on Capacitor Device
  - (D) Capacitor Charging Device
20. For an NMOS inverter the ratio of  $Z_{pu}$  (pull up impedance) and  $Z_{pd}$  (pull down impedance) has to be at least :
- (A) 1 : 4
  - (B) 4 : 1
  - (C) 1 : 2
  - (D) 2 : 1

21. The ratio of electric field intensity  $E$  and magnetic field intensity  $H$  has numerical value in free space :
- (A)  $35 \Omega$
  - (B)  $377 \Omega$
  - (C)  $75 \Omega$
  - (D)  $225 \Omega$
22. Skin depth or depth of penetration in a conductor :
- (1) is inversely proportional to square root of  $\mu$  and  $\sigma$
  - (2) is inversely proportional to square root of  $f$
  - (3) is increased as frequency increases
  - (4) is directly proportional to square root of  $\mu$  and  $\sigma$
- Which statements is/are correct ?
- (A) (1) and (3)
  - (B) (1) and (2)
  - (C) (2) and (4)
  - (D) (4) only
23. CW RADAR gives :
- (A) Range of target
  - (B) Radial velocity of target
  - (C) Size of the target
  - (D) Colour of the target
24. The phase velocity of an electromagnetic wave depends on frequency in aqueous medium, the said phenomenon is called :
- (A) Dispersion
  - (B) Polarization
  - (C) Absorption
  - (D) Scattering
25. A wave guide section in microwave circuits will act as a :
- (A) Band stop filter
  - (B) Low pass filter
  - (C) High pass filter
  - (D) Band pass filter



26. Which of the following properties of electromagnetic waves are *correct* ?
- (1) The energy of electromagnetic wave is divided between electric and magnetic wave vectors equally
  - (2) Electric and magnetic field vectors reach the maxima and minima at the same place and same time
  - (3) Both electric and magnetic field vectors are perpendicular to each other and parallel to the direction of propagation of waves
  - (4) These waves do require material medium to propagate
- (A) (1), (2), (3) and (4)  
(B) (1), (2) and (4)  
(C) (1), (3) and (4)  
(D) (1), (2) and (3)
27. We say transmission is matched when :
- (A)  $Z_L = z_0$
  - (B)  $Z_L = \sqrt{z_0}$
  - (C)  $Z_L = z_0 / 2$
  - (D)  $Z_L = 2z_0$
28. If a transmission line of characteristic impedance  $50 \Omega$  is terminated with a load impedance of  $150 \Omega$ , then VSWR is :
- (A) 0.75
  - (B) 0.5
  - (C) 2
  - (D) 1.4

29. Match List I with List II and select the *correct* answer using the codes given below the list :

**List I**

- (a) Klystron
- (b) Magnetron
- (c) Gunn diode
- (d) PIN diode

**List II**

- (i) Operates on DC power
- (ii) RF amplification by kinetic energy
- (iii) High level injection
- (iv) Operation between 10 GHz to 1 THz

**Codes :**

- (a) (b) (c) (d)
- (A) (i) (ii) (iii) (iv)
- (B) (ii) (i) (iv) (iii)
- (C) (iv) (ii) (iii) (i)
- (D) (i) (iii) (ii) (iv)

30. **Assertion (A) :**

Microstrip is very commonly used in microwave integrated circuits.

**Reason (R) :**

Microstrip has an easy access to the top-surface so that active and passive discrete components can be easily mounted.

- (A) Both (A) and (R) are correct and (R) is correct explanation of (A)
- (B) Both (A) and (R) are correct but (R) is not correct explanation of (A)
- (C) (A) is correct but (R) is wrong
- (D) (A) is wrong but (R) is correct

31. Suppose the modulating signal is

$$m(t) = 2 \cos(2\pi f_m t) \text{ and the carrier}$$

signal is  $y_c(t) = A_c \cos(2\pi f_c t)$ ,

which one of the following is a

conventional AM signal without over

modulation ?

(A)  $x(t) = A_c m(t) \cos(2\pi f_c t)$

(B)  $x(t) = A_c \cos(2\pi f_c t) + \frac{A_c}{4} m(t)$

$$\cos(2\pi f_c t)$$

(C)  $x(t) = A_c [1 + m(t) \cos(2\pi f_c t)]$

(D)  $x(t) = A_c \cos(2\pi f_m t) \cos(2\pi f_c t)$

$$+ A_c \sin(2\pi f_m t) \cos(2\pi f_c t)$$

32. Which of the following communication systems is not suitable in IoT integration ?

(A) Bluetooth

(B) WiFi

(C) IRDA

(D) I<sup>2</sup>C

33. Delta modulation is a special case of DPCM in which only the polarity of the ..... signal is encoded as output.

(A) Summation

(B) Integration

(C) Difference

(D) Differentiation

34. Which among the following is a false statement ?
- (A) Channel encoder is to modify the binary stream in such a way that errors in the received signals can be detected and possibly corrected
  - (B) If the error can be corrected at a receiver without the need to request a retransmission of a message is referred as forward error correction
  - (C) In block encoding the bit stream is partitioned into binary words
  - (D) Binary words from the source will be referred as codewords and those from the channel encoder as data words
35. Which of the following can store, manipulate and retrieve waveform related information ?
- (A) CRO
  - (B) DMM
  - (C) Spectrum analyser
  - (D) DSO
36. Which among the following is a false statement ?
- (A) FDM is not sensitive to propagation delay
  - (B) Channel equalization techniques for FDM are complex than those for TDM system
  - (C) TDM uses relatively simple and less costly digital logic circuit compared to FDM
  - (D) Code division multiplexing allows signals from series of independent sources to be transmitted at the same time over various frequency band
37. MEMS stands for :
- (A) Micro-electro-mechanical systems
  - (B) Miniature electronic measurement systems
  - (C) Motorised electro-mechanical systems
  - (D) Mechanically enhanced micro-systems

38. Match List I with List II and select the correct answer using the codes given below :

**List I**

- (a) Mixer
- (b) VCO
- (c) Ring modulator
- (d) Codes

**List II**

- (i) Convolution
- (ii) Frequency conversion
- (iii) Generation of DSB-SC
- (iv) Generation of FM

**Codes :**

- (a) (b) (c) (d)
- (A) (iii) (i) (iv) (ii)
- (B) (ii) (iii) (iv) (i)
- (C) (iii) (ii) (iv) (i)
- (D) (ii) (iv) (iii) (i)

39. The correct statement for shot noise and Johnson noise is that :

- (a) Shot noise occurs because the carriers do not cross the barrier simultaneously
- (b) Shot noise is a random fluctuation that accompanies any direct current crossing a potential barrier
- (c) Johnson noise arises from thermal cause wherein electron in conductor possess kinetic energy
- (d) Mean noise voltage across the conductor is zero but the root-mean-square value is infinite and cannot be measured

- (A) (a) and (b)
- (B) (a), (b) and (c)
- (C) (d) only
- (D) (a) and (c)

40. Electro-encephalogram (EEG) is a technique used for checking function of :
- (A) Retina
  - (B) Muscular strength
  - (C) Brain
  - (D) Kidney
41. At high frequency operation of SCR :
- (A)  $di/dt$  becomes significant
  - (B)  $dv/dt$  becomes significant
  - (C) Reverse blocking voltage becomes significant
  - (D) Switching losses becomes significant
42. Square wave inverters provide :
- (A) Fixed DC voltage
  - (B) Fixed AC with appreciable low frequency harmonics
  - (C) Fixed DC with low frequency harmonics
  - (D) Variable AC voltage with high frequency harmonics
43. Triac is an integration of :
- (A) A pair of UJT
  - (B) A pair of converter grade SCR connected in anti-parallel
  - (C) A pair of converter grade SCR connected in parallel
  - (D) A pair of converter grade SCR connected in series
44. In high voltage SCR based applications Gate control circuit of SCR prefer fibre optical cable for triggering purpose, because :
- (A) It provides low impedance for power circuit
  - (B) It provides high gain for control circuit
  - (C) It provides very high level of insulation/isolation
  - (D) It provides high current for power circuit

45. Match the pair :

**SET I**

- (a) Chopper
- (b) Dimmerstat
- (c) Inverter
- (d) Phase controlled rectifier

**SET II**

- (i) Variable speed DC drive
- (ii) Variable speed AC drive
- (iii) PMDC motor speed control
- (iv) Variable AC voltage applications

**Codes :**

- (a) (b) (c) (d)
- (A) (i) (ii) (iii) (iv)
- (B) (iv) (iii) (ii) (i)
- (C) (iii) (iv) (ii) (i)
- (D) (iii) (iv) (i) (ii)

46. For a typical  $p-n$  photodiode the width of depletion layer ( $W$ ) is  $10\ \mu\text{m}$  and drift velocity is  $10^5\ \text{m/s}$ , then what is the transit time ?

- (A) 10 PS
- (B) 10000 PS
- (C) 100 PS
- (D) 1000 PS

47. The physical mechanism behind the operation of an Acousto-optic filters in WDM is the :

- (A) Photoelectric effect
- (B) Electro-optical effect
- (C) Electromagnet effect
- (D) Photoelastic effect

48. Grating based demultiplexers use the phenomenon of ..... from an optical grating.

- (A) Diffraction (Bragg)
- (B) Scattering
- (C) Reflection
- (D) Transmission

49. Which of the following would need a 4½ digit digital multimeter ?

- (A) 1.999 mA
- (B) -1.999  $\mu$ V
- (C) 1000 V
- (D) 1.4856 mV

50. The following can be used as WDM component in optical communication :

- (A) Fibre coupler
- (B) Optical filters
- (C) Graded index lens
- (D) Epoxy splicer

51. The one of the disadvantages of magnetic flowmeters is :

- (A) Handle slurries and greasy material only
- (B) Handles corrosive fluids
- (C) Very low pressure drop
- (D) Handles fluids having adequate electrical conductors



52. A basic analog movement with full scale deflection of  $50 \mu\text{A}$  and internal resistance of  $500 \Omega$  (ohm) is used as voltmeter. What is the value of multiplier resistor to get voltage range of  $0 \text{ V}$  to  $10 \text{ V}$  ?

- (A)  $200 \text{ k}\Omega$
- (B)  $195 \text{ k}\Omega$
- (C)  $199.5 \text{ k}\Omega$
- (D)  $199.9 \text{ k}\Omega$

53. The resolution of a  $3\frac{1}{2}$  digit DMM on  $1 \text{ V}$  and  $10 \text{ V}$  is :

- (A)  $0.1 \text{ V}$  and  $0.01 \text{ V}$
- (B)  $0.01 \text{ V}$  and  $0.1 \text{ V}$
- (C)  $0.001 \text{ V}$  and  $0.1 \text{ V}$
- (D)  $0.001 \text{ V}$  and  $0.01 \text{ V}$

54. Match the pair :

**SET I**

- (a) Output power measurement
- (b) High resistance measurement
- (c) pH measurement
- (d) Electrical properties of coil and capacitors

**SET II**

- (i) Q meter
- (ii) Calomel electrode
- (iii) Megger
- (iv) Wattmeter

**Codes :**

- (a) (b) (c) (d)
- (A) (iv) (i) (ii) (iii)
- (B) (iv) (ii) (iii) (i)
- (C) (iv) (iii) (ii) (i)
- (D) (i) (ii) (iii) (iv)

55. For the following the  $R_a/R_b = 1000$ ,  $R_1 = 5 \Omega$  and  $R_1 = 0.5 R_2$ . What is the value of RX ?

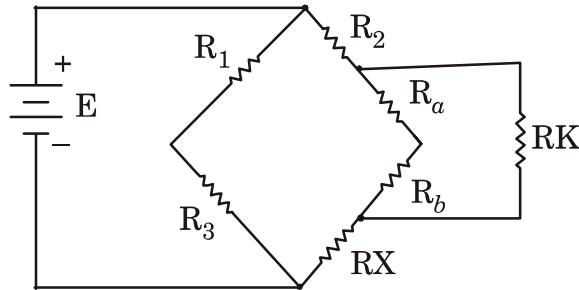

- (A)  $0.001 \Omega$   
 (B)  $0.01 \Omega$   
 (C)  $0.1 \Omega$   
 (D)  $1.0 \Omega$
56. A linear time invariant single input-output system has the state space model given by :

$$dX/dt = FX + GU$$

$$Y = Hz$$

(where, X – State space variable,  
 U – input; Y – output)

What is the output ?

- (A) 0.25  
 (B) 0.5  
 (C) 1  
 (D) 2

57. A transfer function of control system does not have pole-zero cancellation. Which one of the following statements is correct ?

- (A) System is neither controllable nor observable  
 (B) System is completely controllable and observable  
 (C) System is observable but uncontrollable  
 (D) System is controllable but unobservable

58. Loop which do not possess any common node are said to be :

- (A) Forward gain loops  
 (B) Touching loops  
 (C) Non-touching loops  
 (D) Feedback gain loops

59. In a stable control system backlash can cause the following :

- (A) Underdamping
- (B) Overdamping
- (C) Poor stability at reduced values of open loop gains
- (D) Low level oscillations

60. Match the pair :

**SET I**

- (a) Bode plot
- (b) Nyquist criterion
- (c) Z-transform
- (d) Inverse-Laplace transform

**List II**

- (i) Time response solution
- (ii) Sampled data system
- (iii) Frequency response method
- (iv) Stability of control system

**Codes :**

- (a) (b) (c) (d)
- (A) (iii) (iv) (ii) (i)
- (B) (i) (ii) (iii) (iv)
- (C) (iv) (iii) (ii) (i)
- (D) (iv) (i) (iii) (ii)

61. Identify the *correct* expression for the Einstein relation :

- (A)  $\frac{\mu}{D} = \frac{KT}{q}$
- (B)  $\frac{D}{\mu} = \frac{q}{KT}$
- (C)  $\frac{\mu}{D} = \frac{q}{KT}$
- (D)  $\frac{D}{\mu} = \frac{KT}{q}$

62. Which of the following is/are direct band semiconductor/s ?

- (1) GaAs
- (2) Si
- (3) Ge
- (4) InP
- (A) (1) and (4) only
- (B) (2) and (3) only
- (C) (1) and (2) only
- (D) (2) only

63. Which one of the following is the correct expression for the Fermi-Dirac distribution ?

(A)  $f(E) = \frac{1}{e^{(E-E_f)/KT} + 1}$

(B)  $f(E) = \frac{1}{e^{(E_f-E)/KT} + 1}$

(C)  $f(E) = \frac{1}{e^{(E-E_f)/KT} - 1}$

(D)  $f(E) = \frac{1}{e^{(E-E_f) / KT}}$

64. In the process of photolithography, an optical stepper is used for the exposure of the wafers. Write the correct order of various processes starting from the light source to the die on wafer in an optical stepper.

(1) Illumination diffuser

(2) Condenser lens

(3) Reficle

(4) Interferometer

(A) (1), (3), (2), (4)

(B) (1), (2), (3), (4)

(C) (3), (1), (2), (4)

(D) (4), (1), (2), (3)

65. Wet oxidation is given by :

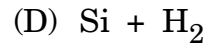
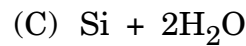
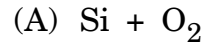

66. In, ..... device the conductivity of a layer of a semiconductor is modulated by a transverse electric field.

(A) BJT

(B) P-N diode

(C) Zener diode

(D) FET

67. Which of the following statements is *correct* when the effective mass of an electron is taken into account ?

(A) Electrons near the top of the valence band have negative effective mass

(B) Electrons near the top of the valence band have positive effective mass

(C) Holes near the top of the valence band have negative effective mass

(D)  $d^2E/dK^2$  is negative at the conduction band minima

68. Si sample is doped with  $10^{10}$  arsenic atoms/cm<sup>3</sup>. What is the equilibrium hole concentration  $p_0$  at 300°K if intrinsic hole and electron concentration  $n_i = 1.5 \times 10^{10}$  atoms/cm<sup>3</sup> ?

- (A)  $1.5 \times 10^{10} \text{ cm}^{-3}$   
 (B)  $2.25 \times 10^{10} \text{ cm}^{-3}$   
 (C)  $3.25 \times 10^{10} \text{ cm}^{-3}$   
 (D)  $4.5 \times 10^{10} \text{ cm}^{-3}$

69. After the photoresist pattern is formed, which of the process is followed :

- (A) Oxidation  
 (B) Masking  
 (C) Etching  
 (D) Bonding

70. Match List I with List II and select the *correct* answer using the codes given below :

**List I**

- (a) BJT  
 (b) Tunnel diode  
 (c) Zener diode  
 (d) MOSFET

**List II**

- (i) High  $\beta$   
 (ii) Voltage regulator  
 (iii) Heavily doped diode  
 (iv) High input impedance

**Codes :**

- (a) (b) (c) (d)  
 (A) (iv) (ii) (iii) (i)  
 (B) (i) (iii) (ii) (iv)  
 (C) (ii) (iv) (iii) (i)  
 (D) (i) (iv) (ii) (iii)

71. The Laplace transform of a unit step function is :

- (A)  $\frac{1}{s}$   
 (B) 1  
 (C)  $\frac{1}{s^2}$   
 (D)  $\frac{1}{s+a}$

72. Find the power dissipation in the resistor of the following circuit :

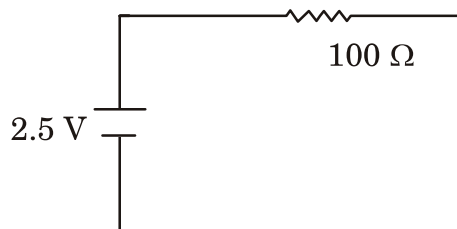

- (A) 100 W  
 (B) 0.4 W  
 (C) 6.25 W  
 (D) 25 W

73. Find the value of  $V_{TH}$  using the Thevenin's theorem of the following circuit :

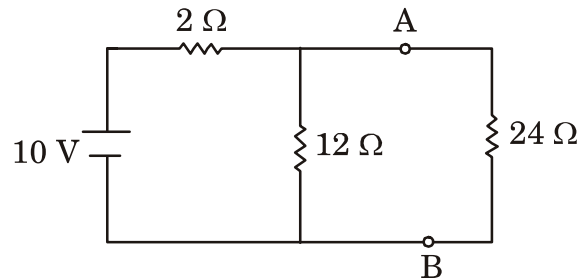

- (A) 7.92 V  
 (B) 8.57 V  
 (C) 1.71 V  
 (D) 8.35 V

74. Let a system be represented by :

$$F(s) = \frac{s(s-1+j2)(s-1-j2)}{(s+2)(s+j1)(s-j1)}$$

Identify which one of the following do not define a zero ?

- (A)  $1 - j2$   
 (B) 0  
 (C) -2  
 (D)  $1 + j2$

75. Match the List I with List II and select the *correct* answer using the codes given below :

**List I**

**(Function)**

- (a) Impulse  
 (b) Pulse  
 (c) Sine wave  
 (d) DC/constant signal

**List II**

**(Fourier Transform)**

- (i) Sin C function  
 (ii) Impulse function at zero  
 (iii) Constant function  
 (iv) Impulse function at corresponding frequency

**Codes :**

- (a) (b) (c) (d)  
 (A) (iii) (i) (iv) (ii)  
 (B) (iii) (ii) (i) (iv)  
 (C) (i) (ii) (iii) (iv)  
 (D) (ii) (i) (iv) (iii)

76. For a reciprocal or bilateral two port network, which of the following is correct for the shown circuit ?

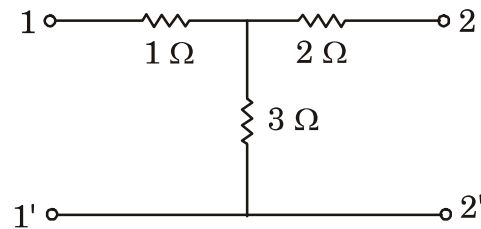

- (A)  $Z_{11} = Z_{22}$   
 (B)  $Z_{12} = Z_{21}$   
 (C)  $Z_{11} = Z_{12}$   
 (D)  $Z_{12} = Z_{22}$
77. Fourier transform of  $e^{iw_0t} x(t)$  is :

- (A)  $X(jw_0)$   
 (B)  $X(jw - w_0)$   
 (C)  $X(jw), e^{-jw_0}$   
 (D)  $X(jw)$

78. Z transform of  $a^n x(n)$  is :

- (A)  $X(az)$
- (B)  $X(a/z)$
- (C)  $X(z/a)$
- (D)  $X(z^n/a^n)$

79. For the following circuit, find the voltage needed across  $a - b$  terminal so that drop across the  $10 \Omega$  resistor is  $20 \text{ V}$  :

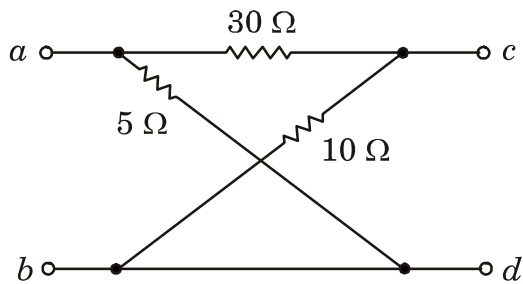

- (A)  $20 \text{ V}$
- (B)  $40 \text{ V}$
- (C)  $60 \text{ V}$
- (D)  $80 \text{ V}$

80. State variable analysis is applicable to :

- (1) LTI systems
- (2) Time varying systems
- (3) Non-linear systems

Which one of the following is/are correct ?

- (A) (1) and (2) only
- (B) (1), (2) and (3)
- (C) (2) and (3)
- (D) (1) only



81. Practical value of loop gain  $A\beta$  is always set slightly higher than 1 to compensate :

- (A) Noise
- (B) Phase shift
- (C) Non-linearity
- (D) Change in feedback voltage

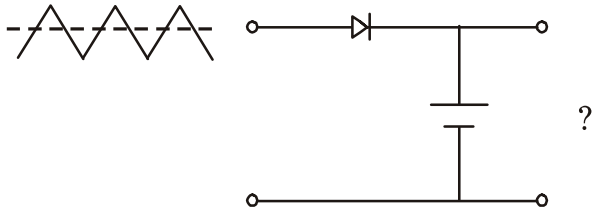

82. For the triangular wave input to the circuit as shown in figure the output waveform will be :

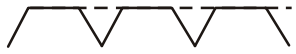

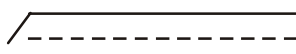
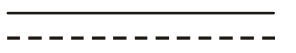
- (A) 
- (B) 
- (C) 
- (D) 
83. The conventional rectifier works well for voltages much larger than 0.7 V. Which of the following can be used for smaller voltages (of the order of few millivolts) :
- (A) Active filter
- (B) Precision rectifier
- (C) Amplifier
- (D) Bridge rectifier

84. Silicon controlled rectifier is a semiconductor device with :

- (A) 2 junctions
- (B) 1 junction
- (C) 4 junctions
- (D) 3 junctions

85. Open loop voltage gain of an amplifier is 80. When a negative feedback of 4% is provided, the gain would be :

- (A) 16
- (B) 100
- (C) 80
- (D) 24

86. For converting a triangular wave to a wave shape close to a sinusoidal wave which circuit would be used ?

- (A) Clamper
- (B) Rectifier
- (C) Clipper
- (D) Integrator

87. The VCO in a PLL operates over a frequency range between 350 kHz and 450 kHz. The lock range of the PLL would be :

- (A) 350 kHz
- (B) 100 kHz
- (C) 450 kHz
- (D) 200 kHz

88. Which of the following represents the *correct* sequence in ascending order of bandwidth ?

- (A) dc amplifier, audio amplifier, radio amplifier, video amplifier
- (B) audio amplifier, radio amplifier, dc amplifier, video amplifier
- (C) video amplifier, radio amplifier, audio amplifier, dc amplifier
- (D) radio amplifier, dc amplifier, audio amplifier, video amplifier

89. Match List I with List II and select the *correct* answer using the codes given below the lists :

**List I**

- (a) Oscillator
- (b) Amplifier
- (c) Active filter
- (d) JFET

**List II**

- (i) Reverse biased input junction
- (ii) Noise rejection
- (iii) Enhanced output
- (iv) Positive feedback

**Codes :**

- (a) (b) (c) (d)
- (A) (i) (ii) (iii) (iv)
- (B) (ii) (iv) (i) (iii)
- (C) (iii) (i) (iv) (ii)
- (D) (iv) (iii) (ii) (i)

90. **Assertion (A) :**

Active filters are better than passive filters in terms of price and performance.

**Reason (R) :**

Integrated circuit technology has made available cheaper operational amplifiers.

- (A) Both (A) and (R) are true and (R) is the correct explanation of (A)
- (B) Both (A) and (R) are true but (R) is not the correct explanation of (A)
- (C) (A) is true but (R) is false
- (D) (A) is false but (R) is true

91. The Boolean function

$$A(x, y, z) = \Sigma(0, 3, 4, 6)$$

$$B(x, y, z) = \Sigma(0, 1, 4, 7)$$

$$C(x, y, z) = \Sigma(1, 5)$$

$$D(x, y, z) = \Sigma(0, 1, 3, 5, 7)$$

can be implemented using a :

- (A)  $4 \times 4$  ROM
- (B)  $8 \times 2$  ROM
- (C)  $16 \times 2$  ROM
- (D)  $8 \times 4$  ROM
92. Number of 2-input multiplexers required to construct a  $2^{10}$  input multiplexer is :
- (A) 32
- (B) 9
- (C) 128
- (D) 1023

93. A JKMS flip-flop has the characteristic that :

- (A) Change in the input is immediately reflected in the output
- (B) Change in the output occurs when the state of the master is affected
- (C) Change in the output occurs when the state of the slave is affected
- (D) Both the master and the slave states are affected at the same time

94. A 4-bit ring counter is loaded with 1000 data and 100 kHz clock input. The output at  $Q_0$  would be :

- (A) 50 kHz with 50% duty cycle
- (B) 25 kHz with 25% duty cycle
- (C) 50 kHz with 25% duty cycle
- (D) 25 kHz with 50% duty cycle

95. An 8-bit successive approximation analog to digital converter has full scale reading of 2.55 V and its conversion time for an analog input of 1 V is 20  $\mu$ S. The conversion time for a 2 V input will be :

- (A) 10  $\mu$ S
- (B) 20  $\mu$ S
- (C) 40  $\mu$ S
- (D) 50  $\mu$ S

**96–99 : Dual-Slope A/D**

Another type of A/D conversion scheme is the dual-slope A/D converter shown below. This type of converter is found in high-resolution data acquisition systems, for example, since 20-bit conversions can be achieved.

From figure below at  $t = 0$ , the reset switch  $S_1$  opens and a negative input signal ( $-v'_A$ ) is applied to the integrator. The input signal  $v'_A$  is a sampled portion of the analog signal  $v_A$  and hence is a constant during the conversion process. The output  $v_{01}$  of the integrator is a positive linear signal as shown in the timing diagram. The slope of the signal is proportional to the value of  $v'_A$ . This portion of the conversion process continues for a fixed time  $T_1$ , at which time the counter has reached its maximum value and overflows.

At this time, the input switch  $S_2$  changes to a positive input reference voltage  $V_{REF}$ . The output of the integrator starts at the peak output

voltage reached at  $T_1$  and now has a negative slope. The counter has been reset and is now counting. The counting stops when the output voltage  $v_{01}$  reaches zero.

The time  $T_2$  is related to  $T_1$  and  $v'_A$  by :

$$T_2 = T_1 \left( \frac{v'_A}{V_{REF}} \right)$$

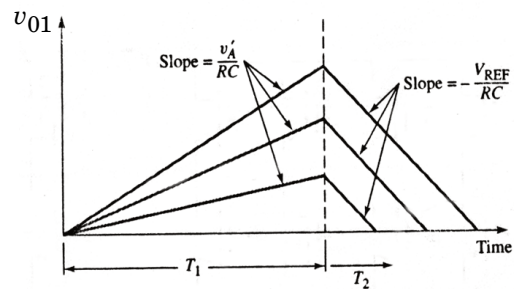
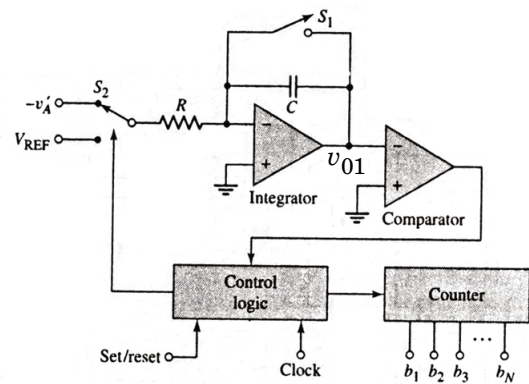

96. The characteristic of the above converter is relatively linear because :

- (A)  $V_{01}$  Vs. T graphs are linear
- (B) Uses same capacitor for charge and discharge
- (C) High performance linear comparator
- (D) High performance op-amp

97. The switch S1 is used for the following operation :

- (A) Discharge the capacitor at end of  $T_1$
- (B) Discharge capacitor of residual voltage at end of  $T_2$
- (C) Starting of A/D operation
- (D) Reset during over flow

98. The converted output of the ADC depends upon :

- (A) Value of R
- (B) Value of C
- (C)  $T_2$
- (D)  $T_1$

99. The simple and high resolution ADC converter are based on ..... principle.

- (A) Flash converter
- (B) Dual slope A/D
- (C) SAR
- (D) Counting

100. The following state diagram represents :

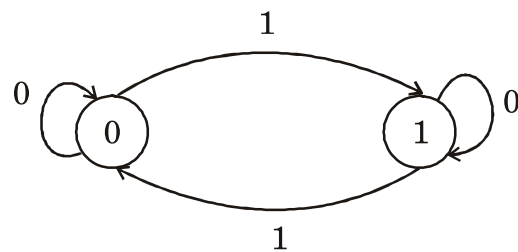

- (A) Serial Adder
- (B) Shift Register
- (C) Serial Parity Checker
- (D) Counter

**MAR - 38223/II—C**

**ROUGH WORK**

**MAR - 38223/II—C**

**ROUGH WORK**