

Test Booklet Code & Serial No.

प्रश्नपत्रिका कोड व क्रमांक

Paper-II

A

PHYSICAL SCIENCE

Signature and Name of Invigilator

Seat No.

--	--	--	--	--	--	--	--

1. (Signature)

(In figures as in Admit Card)

(Name)

Seat No.

(In words)

2. (Signature)

(Name)

OMR Sheet No.

--	--	--	--	--	--	--	--

(To be filled by the Candidate)

MAR - 32223

Time Allowed : 2 Hours]

[Maximum Marks : 200

Number of Pages in this Booklet : 24

Number of Questions in this Booklet : 100

Instructions for the Candidates

- Write your Seat No. and OMR Sheet No. in the space provided on the top of this page.
- This paper consists of **100** objective type questions. Each question will carry *two* marks. *All* questions of Paper II will be compulsory.
- At the commencement of examination, the question booklet will be given to the student. In the first 5 minutes, you are requested to open the booklet and compulsorily examine it as follows :
 - To have access to the Question Booklet, tear off the paper seal on the edge of this cover page. Do not accept a booklet without sticker-seal or open booklet.
 - Tally the number of pages and number of questions in the booklet with the information printed on the cover page. Faulty booklets due to missing pages/questions or questions repeated or not in serial order or any other discrepancy should not be accepted and correct booklet should be obtained from the invigilator within the period of 5 minutes. Afterwards, neither the Question Booklet will be replaced nor any extra time will be given. The same may please be noted.
 - After this verification is over, the OMR Sheet Number should be entered on this Test Booklet.
- Each question has four alternative responses marked (A), (B), (C) and (D). You have to darken the circle as indicated below on the correct response against each item.
Example : where (C) is the correct response.

<input type="radio"/>	<input type="radio"/>	<input checked="" type="radio"/>	<input type="radio"/>
A	B	C	D
- Your responses to the items are to be indicated in the **OMR Sheet given inside the Booklet only**. If you mark at any place other than in the circle in the OMR Sheet, it will not be evaluated.
- Read instructions given inside carefully.
- Rough Work is to be done at the end of this booklet.
- If you write your Name, Seat Number, Phone Number or put any mark on any part of the OMR Sheet, except for the space allotted for the relevant entries, which may disclose your identity, or use abusive language or employ any other unfair means, you will render yourself liable to disqualification.
- You have to return original OMR Sheet to the invigilator at the end of the examination compulsorily and must not carry it with you outside the Examination Hall. You are, however, allowed to carry the Test Booklet and duplicate copy of OMR Sheet on conclusion of examination.
- Use only Blue/Black Ball point pen.
- Use of any calculator or log table, etc., is prohibited.
- There is no negative marking for incorrect answers.

विद्यार्थ्यांसाठी महत्वाच्या सूचना

- परीक्षार्थींनी आपला आसन क्रमांक या पृष्ठावरील वरच्या कोपऱ्यात लिहावा. तसेच आपणांस दिलेल्या उत्तरपत्रिकेचा क्रमांक त्याखाली लिहावा.
- सदर प्रश्नपत्रिकेत **100** बहुपर्यायी प्रश्न आहेत. प्रत्येक प्रश्नास **दोन** गुण आहेत. या प्रश्नपत्रिकेतील **सर्व** प्रश्न सोडविणे अनिवार्य आहे.
- परीक्षा सुरू झाल्यावर विद्यार्थ्यांला प्रश्नपत्रिका दिली जाईल. सुरुवातीच्या 5 मिनिटांमध्ये आपण सदर प्रश्नपत्रिका उघडून खालील बाबी अवश्य तपासून घ्याव्यात.
 - प्रश्नपत्रिका उघडण्यासाठी प्रश्नपत्रिकेवर लावलेले सील उघडावे. सील नसलेली किंवा सील उघडलेली प्रश्नपत्रिका स्वीकारू नये.
 - पहिल्या पृष्ठावर नमूद केल्याप्रमाणे प्रश्नपत्रिकेची एकूण पृष्ठे तसेच प्रश्नपत्रिकेतील एकूण प्रश्नांची संख्या पडताळून घ्यावी. पृष्ठे कमी असलेली/कमी प्रश्न असलेली/प्रश्नांचा चुकीचा क्रम असलेली किंवा इतर त्रुटी असलेली सदोष प्रश्नपत्रिका सुरुवातीच्या 5 मिनिटांतच पर्यवेक्षकाला परत देऊन दुसरी प्रश्नपत्रिका मागवून घ्यावी. त्यानंतर प्रश्नपत्रिका बदलून मिळणार नाही तसेच वेळही वाढवून मिळणार नाही याची कृपया विद्यार्थ्यांनी नोंद घ्यावी.
 - वरीलप्रमाणे सर्व पडताळून पाहिल्यानंतरच प्रश्नपत्रिकेवर ओ.एम.आर. उत्तरपत्रिकेचा नंबर लिहावा.
- प्रत्येक प्रश्नासाठी (A), (B), (C) आणि (D) अशी चार विकल्प उत्तरे दिली आहेत. त्यातील योग्य उत्तराचा रकाना खाली दर्शविल्याप्रमाणे ठळकपणे काळा/निळ्या करावा.
उदा. : जर (C) हे योग्य उत्तर असेल तर.

<input type="radio"/>	<input type="radio"/>	<input checked="" type="radio"/>	<input type="radio"/>
A	B	C	D
- या प्रश्नपत्रिकेतील प्रश्नांची उत्तरे ओ.एम.आर. उत्तरपत्रिकेतच दर्शावावीत. इतर ठिकाणी लिहिलेली उत्तरे तपासली जाणार नाहीत.
- आत दिलेल्या सूचना काळजीपूर्वक वाचाव्यात.
- प्रश्नपत्रिकेच्या शेवटी जोडलेल्या कोऱ्या पानावरच कच्चे काम करावे.
- जर आपण ओ.एम.आर. वर नमूद केलेल्या ठिकाणाव्यतिरिक्त इतर कोठेही नाव, आसन क्रमांक, फोन नंबर किंवा ओळख पटेल अशी कोणतीही खूप केलेली आढळून आल्यास अथवा असभ्य भाषेचा वापर किंवा इतर गैरमार्गांचा अवलंब केल्यास विद्यार्थ्यांला परीक्षेस अपात्र ठरविण्यात येईल.
- परीक्षा संपल्यानंतर विद्यार्थ्यांने मूळ ओ.एम.आर. उत्तरपत्रिका पर्यवेक्षकांकडे परत करणे आवश्यक आहे. तथापि, प्रश्नपत्रिका व ओ.एम.आर. उत्तरपत्रिकेची द्वितीय प्रत आपल्याबरोबर नेण्यास विद्यार्थ्यांना परवानगी आहे.
- फक्त निळ्या किंवा काळ्या बॉल पेनचाच वापर करावा.
- कॅलक्युलेटर किंवा लॉग टेबल वापरण्यास परवानगी नाही.
- चुकीच्या उत्तरासाठी गुण कपात केली जाणार नाही.

MAR - 32223/II—A

5. The integral

$$\frac{1}{2\pi i} \oint \frac{\exp\left[\frac{z}{2}\left(t - \frac{1}{t}\right)\right]}{t^{n+1}} dt,$$

where n is an integer and the closed contour is a circle enclosing the origin, can be used to :

- (A) generate Hermite polynomials
- (B) generate Bessel's functions of first kind
- (C) generate Legendre polynomials
- (D) generate associated Legendre polynomials

6. The value of $\oint z \exp\left(\frac{1}{z}\right) dz$, where

the closed contour is a unit circle traversed anticlockwise is :

- (A) πi (B) $2\pi i$
- (C) π (D) 0

7. Consider vectors $\vec{a} = \hat{i} + 5\hat{j} + \hat{k}$, $\vec{b} = \hat{i} - 5\hat{j} + \hat{k}$ and $\vec{c} = \hat{i} + \hat{k}$. Which of the following statements is true ?

- (A) $\vec{a}, \vec{b}, \vec{c}$ are linearly independent
- (B) $\vec{a}, \vec{b}, \vec{c}$ are linearly dependent
- (C) $\vec{a}, \vec{b}, \vec{c}$ are orthogonal
- (D) $\vec{a}, \vec{b}, \vec{c}$ are normalized

8. Consider the following probability density function :

$$P(x) = 0 \quad x < -2 \text{ and } x > 3$$

$$P(x) = a \quad -2 < x < 2$$

$$P(x) = \frac{1}{12} \quad 2 < x < 3$$

The value of a is :

- (A) $\frac{11}{12}$ (B) $\frac{1}{12}$
- (C) $\frac{11}{48}$ (D) $\frac{1}{48}$

9. The Green's function $G(x, x_0)$ satisfying the equation

$$\frac{d^2G(x, x_0)}{dx^2} = \delta(x - x_0)$$

with boundary conditions $G(-L, x_0) = G(L, x_0) = 0$ is :

(A) $\begin{cases} \frac{1}{2L}(L - x_0)(x + L) & -L \leq x \leq x_0 \\ \frac{1}{2L}(x_0 + L)(L - x) & x_0 \leq x \leq L \end{cases}$

(B) $\begin{cases} \frac{1}{2L}(x_0 + L)(x + L) & -L \leq x \leq x_0 \\ \frac{1}{2L}(x_0 - L)(x - L) & x_0 \leq x \leq L \end{cases}$

(C) $\frac{1}{2L}(x - L)(x + L) \quad -L \leq x \leq L$

(D) $\begin{cases} \frac{1}{2L}(x_0 - L)(x + L) & -L \leq x \leq x_0 \\ \frac{1}{2L}(x_0 + L)(x - L) & x_0 \leq x \leq L \end{cases}$

10. Two students solved the Poisson's equation $\nabla^2\phi = -\frac{\rho_0}{\epsilon_0}$ (the symbols have usual meanings). They obtained two different answers $\phi_1(x) = -\frac{1}{2} \frac{\rho_0 x^2}{\epsilon_0}$ and $\phi_2(y) = -\frac{1}{2} \frac{\rho_0 y^2}{\epsilon_0}$. What is the reason ?
- (A) Space is isotropic, hence x and y are equivalent
- (B) We can add solution of Laplace's equation to both
- (C) The boundary conditions are different in the two cases
- (D) One of them was wrong
11. The equation $\tan(2x) = x^2 - 4$ has :
- (A) One real root
- (B) Two real roots
- (C) No real root
- (D) Infinitely many real roots
12. The order of magnitude of the error in estimating the value of integral $\int_0^{10} (5x + 6)dx$ numerically using trapezoidal method with a step size of 0.1 is :
- (A) 0 (B) 10^{-2}
- (C) 10^{-3} (D) 10^{-1}
13. The deflection of a structure under loading is measured at five different values of the force applied X in kilo Newtons (kN). The deflection Y is in centimetres. Data are given in the following table. Employing Lagrange's interpolation with quadratic polynomial, compute the extrapolated value of the deflection Y for zero load ($X = 0$ kN). How many points are used ?
- | | | | | | |
|--------|-----|-----|-----|-----|------|
| X (kN) | 0.5 | 1.0 | 1.5 | 2.0 | 2.5 |
| Y (cm) | 3.0 | 3.9 | 5.2 | 7.3 | 10.5 |
- (A) 4.05, 2 (B) 2.50, 3
- (C) 2.00, 4 (D) 2.00, 5
14. Which of the following equations represents a conservative force ?
- (A) $\vec{F} = (xy + z^2)\hat{i} + x^2\hat{j} - 2xz\hat{k}$
- (B) $\vec{F} = (2xy + z^2)\hat{i} + x^2\hat{j} + 2xz\hat{k}$
- (C) $\vec{F} = (xy - z^2)\hat{i} - x^2\hat{j} + 2xz\hat{k}$
- (D) $\vec{F} = (xy - z^2)\hat{i} + x^2\hat{j} + 2xz\hat{k}$

15. For a particle moving under the action of a central force, the correct relation between the energy (E) of the particle, eccentricity (e) of the conic section describing the orbit, reduced mass (μ), angular momentum (\bar{l}), and the force constant (k) is given by :

- (A) $E = \frac{\mu k^2}{2l^2} (e^2 - 1)$
- (B) $E = \frac{\mu k^2}{l^2} (1 - e^2)$
- (C) $E = \frac{\mu k^2}{l^2} (1 + e^2)$
- (D) $E = \frac{\mu k^2}{2l^2} (e^2 + 1)$

16. Consider two frames XYZ and xyz having common origin. The frame XYZ is fixed and the frame xyz is rotating with angular velocity (ω) with respect to the frame XYZ. Here $\bar{\omega} = 2t\hat{x} - 5t^2\hat{z}$, where t represents time. For a given position vector (\bar{r}) defined as $\bar{r} = 4t^2\hat{x} + 6t\hat{y} + t^3\hat{z}$ in the xyz coordinate frame, the velocities in frames XYZ and xyz for $t = 1$, will be respectively :

- (A) $8\hat{x} - 6\hat{y} + 3\hat{z}$ and $38\hat{x} + 16\hat{y} + 15\hat{z}$
- (B) $38\hat{x} - 16\hat{y} + 15\hat{z}$ and $8\hat{x} + 6\hat{y} + 3\hat{z}$
- (C) $8\hat{x} + 6\hat{y} + 3\hat{z}$ and $38\hat{x} - 16\hat{y} + 15\hat{z}$
- (D) $38\hat{x} + 16\hat{y} + 15\hat{z}$ and $8\hat{x} - 6\hat{y} + 3\hat{z}$

17. A circular platform is rotating with uniform angular speed ω counter-clockwise about an axis passing through its center and perpendicular to its plane (as shown in figure). A person of mass m walks radially inwards with a uniform speed v on the platform. The magnitude and direction of the Coriolis force (with respect to the direction along which the person walks) is :

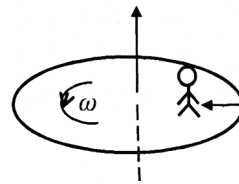

- (A) $mv\omega$ towards his right
- (B) $2mv\omega$ towards his right
- (C) $mv\omega$ towards his left
- (D) $2mv\omega$ towards his left

18. Consider an inverted pendulum comprised of a mass m attached to a rigid massless rod of length l as shown in figure. The point 'O' exhibits vertical motion (along z direction) described by equation $z = a \sin \omega t$, where ω is constant. The Lagrangian of the system is given as :

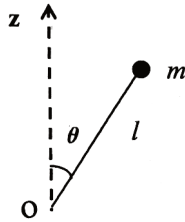

- (A) $L = \frac{1}{2} ml^2 \dot{\theta}^2 - m(g - a\omega^2 \sin \omega t)l \cos \theta$
- (B) $L = \frac{1}{2} m(l^2 \dot{\theta}^2 + a^2 \omega^2 \cos^2 \omega t) - mgl \cos \theta$
- (C) $L = \frac{1}{2} m(l^2 \dot{\theta}^2 + a^2 \omega^2 \sin^2 \omega t) - mgl \cos \theta$
- (D) $L = \frac{1}{2} ml^2 \dot{\theta}^2 - m(g + a\omega^2 \cos \omega t)l \cos \theta$

19. A mass spring system consists of two blocks of mass M and one block of mass m ($<M$). The blocks are connected with two springs of same spring constant (k), as shown in figure. The system is constraint to move along a straight line on a frictionless horizontal surface. Let V represent the potential energy of the system. Considering that the masses are exhibiting small oscillations, the potential energy matrix (V) is given as :

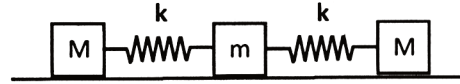

- (A) $\frac{1}{2} \begin{pmatrix} k & -k & 0 \\ -k & 2k & -k \\ 0 & -k & k \end{pmatrix}$
- (B) $\frac{1}{2} \begin{pmatrix} k & 0 & -k \\ 0 & 2k & k \\ -k & k & 0 \end{pmatrix}$
- (C) $\frac{1}{2} \begin{pmatrix} k & -k & 0 \\ k & 2k & k \\ 0 & k & k \end{pmatrix}$
- (D) $\frac{1}{2} \begin{pmatrix} -k & 0 & k \\ 0 & 2k & -k \\ k & k & k \end{pmatrix}$

20. Consider two persons A and B of same age, 20 years. Person A remains rest at origin, whereas person B takes a roundtrip space voyage to a star with velocity $v = 0.99c$ relative to person A (where c is the speed of light). The round trip distance travelled by the person B is 20 light years. When B meets A after completion of the space voyage, their ages are :
- (A) A : 40.2 yrs, B : 40.2 yrs
 (B) A : 40.2 yrs, B : 22.8 yrs
 (C) A : 22.8 yrs, B : 22.8 yrs
 (D) A : 40.8 yrs, B : 40.2 yrs
21. The number of degrees of freedom describing motion of a swimmer in a swimming pool is :
- (A) 3 (B) 5
 (C) 6 (D) 9
22. For a conservative dynamical system, the area enclosed by the phase space :
- (A) Increases with time
 (B) Remains constant with time
 (C) Decreases with time
 (D) Oscillates with time
23. Hamilton's principal function S and Hamilton's characteristic function W for a conservative system, are related as :
- (A) $S(q_k, t) = W(q_k) - E$
 (B) $S(q_k, t) = W(q_k) + E$
 (C) $S(q_k, t) = W(q_k) + Et$
 (D) $S(q_k, t) = W(q_k) - Et$
24. For a particle moving in an inverse square force field, $V(r) = -\frac{K}{r}$, the action angle variable analysis gives :
- (A) only one frequency of oscillation
 (B) two similar frequencies of oscillation
 (C) two dissimilar frequencies of oscillation
 (D) more than two dissimilar frequencies of oscillation
25. If \mathbf{J} is the current density and ρ is the electric charge density, then equation $\vec{\nabla} \cdot \vec{j} + \frac{\partial \rho}{\partial t} = 0$ represents :
- (A) wave equation
 (B) continuity equation
 (C) Poisson's equation
 (D) Laplace's equation

26. If the potential function is a step function, the relevant equation is :
- (A) Laplace's equation
 (B) Poisson's equation
 (C) Maxwell's equation
 (D) Ampere's equation
27. An electric field applied along the length of a long circular cylinder produces a polarization P. The depolarization field produced in this configuration is :
- (A) $4\pi P / 3$ (B) $-4\pi P / 3$
 (C) $2\pi P$ (D) 0
28. The electric field of an electromagnetic wave is $\vec{E} = i\sqrt{2} \sin(kz - \omega t)$ V/m. The average flow energy per unit area per unit time, due to this wave is :
- (A) 27×10^4 W/m²
 (B) 27×10^{-4} W/m²
 (C) 27×10^{-2} W/m²
 (D) 27×10^2 W/m²
29. When a monoatomic gas atom is placed in a uniform electric field, the resulting induced dipole moment is :
- (A) proportional to E
 (B) proportional to E²
 (C) proportional to E³
 (D) independent of E
30. The reflection coefficient k_r , characteristic impedance Z_0 , and load impedance Z_L of a transmission line are connected together by the relation :
- (A) $k_r = \frac{Z_L + Z_0}{Z_0 - Z_L}$
 (B) $k_r = \frac{Z_L Z_0}{Z_0 - Z_L}$
 (C) $k_r = \frac{Z_L - Z_0}{Z_0 + Z_L}$
 (D) $k_r = \frac{Z_L - Z_0}{Z_0 Z_L}$

31. Using Biot-Savart law, the magnetic induction at a distance d , from an infinitely long straight wire in which current I is flowing along the z -direction, is :
- (A) $(\mu_0 / 4\pi)\hat{k}$
 (B) $(\mu_0 / 4\pi)(2I / d)\hat{k}$
 (C) $(\mu_0 / 4\pi)(I / d)\hat{k}$
 (D) $(\mu_0 I / 4\pi)\hat{k}$
32. Magnitude of electric field at large distance r , from an ideal electric dipole is proportional to :
- (A) r^2 (B) r^{-2}
 (C) r^{-3} (D) r^{-4}
33. At the uncharged interface between two linear dielectrics with permittivities ϵ_1 and ϵ_2 , electric fields \vec{E}_1 and \vec{E}_2 make angles θ_1 and θ_2 with the normal. The ratio ϵ_1 / ϵ_2 is equal to :
- (A) $\tan\theta_1/\tan\theta_2$
 (B) $\sin\theta_1/\sin\theta_2$
 (C) $\cos\theta_1/\cos\theta_2$
 (D) $\cot\theta_1/\cot\theta_2$
34. Charge Q is divided into two parts which are then kept at distance d apart. The force between them will be maximum if the charges on two parts are :
- (A) $Q/4$ and $3Q/4$
 (B) $Q/3$ and $2Q/3$
 (C) $Q/2$ and $Q/2$
 (D) any q_1 and q_2 such that $q_1 + q_2 = Q$; $q_1 > 0$, $q_2 > 0$
35. For uniformly charged solid sphere of radius R , which of the following statements is correct about the magnitude of electric field at a distance r from the center of the sphere ?
- (A) $E = 0$ for $r < R$
 (B) $E =$ non-zero constant for $r < R$
 (C) E proportional to r , for $r < R$
 (D) E proportional to $1/r$, for $r < R$

36. A particle of mass m is confined in a three-dimensional cubical box of size L . The number of eigenstates of the Hamiltonian with energy $\frac{19\hbar^2\pi^2}{mL^2}$ is :

- (A) 10 (B) 4
(C) 3 (D) 9

37. Consider an anisotropic two-dimensional oscillator given by the Hamiltonian

$$H = -\frac{\hbar^2}{2m} \left(\frac{\partial^2}{\partial x^2} + \frac{\partial^2}{\partial y^2} \right) + \frac{1}{2} m\omega^2 x^2 + 2m\omega^2 y^2$$

The eigen energy of the oscillator is given by :

- (A) $E_n = (n + 3/2)\hbar\omega$
(B) $E_n = (n + 1)\hbar\omega$
(C) $E_n = (2n + 1)\hbar\omega$
(D) $E_n = (n + 2/3)\hbar\omega$

38. For a one-dimensional harmonic oscillator, a^+ and a are raising and lowering operators and $|n\rangle$ is the n th energy eigenstate. Then $a^+ a |n + 1\rangle$ is equal to :

- (A) $(n + 1) |n\rangle$
(B) $n |n + 1\rangle$
(C) $\sqrt{n(n + 1)} |n + 1\rangle$
(D) $(n + 1) |n + 1\rangle$

39. If \bar{A} and \bar{B} are quantum mechanical operators, then $[[\bar{A}, \bar{B}], [\bar{B}, \bar{A}]]$ is equal to :

- (A) $\bar{A} \bar{B} \bar{B} \bar{A} - \bar{B} \bar{A} \bar{A} \bar{B}$
(B) 0
(C) $\bar{A} \bar{A} \bar{B} - \bar{B} \bar{B} \bar{A}$
(D) $[A, B]^2$

40. Sixteen non-interacting electrons are confined in an infinite box of side a . The energies of the least energetic and the most energetic electrons in the ground state of the system are :

(A) $\frac{\hbar^2\pi^2}{2ma^2}, \frac{32\hbar^2\pi^2}{ma^2}$

(B) $0, \frac{32\hbar^2\pi^2}{ma^2}$

(C) $\frac{\hbar^2\pi^2}{2ma^2}, \frac{\hbar^2\pi^2}{2ma^2}$

(D) $\frac{\hbar^2\pi^2}{2ma^2}, \frac{128\hbar^2\pi^2}{ma^2}$

41. Using the triangular trial wave function :

$$\psi(x) = \begin{cases} Ax & \text{for } 0 \leq x \leq a/2 \\ A(a-x) & \text{for } \frac{a}{2} \leq x \leq a \\ 0 & \text{otherwise} \end{cases}$$

an upper bound on the ground state energy of the one-dimensional infinite square well is :

(A) $\frac{8\hbar^2}{ma^2}$ (B) $\frac{7\hbar^2}{ma^2}$

(C) $\frac{6\hbar^2}{ma^2}$ (D) $\frac{5\hbar^2}{ma^2}$

42. A hydrogen atom is perturbed by a potential $H_1 = bx^2$. The first order correction to ground state energy is (a_0 is the Bohr radius) :

(A) ba_0^2 (B) $2ba_0^2$

(C) $ba_0^2/2$ (D) $ba_0^2/4$

43. Consider a particle of mass m in a one-dimensional box with walls at $x = 0$ and $x = L$ with ground state energy E_1 . If the separation between the walls is adiabatically (slowly) increased to $2L$, the change in the ground state energy is given by :

(A) 0 (B) $\frac{2}{3}E_1$

(C) $\frac{3}{8}E_1$ (D) $\frac{3}{2}E_1$

44. In scattering theory of spherically symmetric potential, the incident particles on z -axis are represented by :

(A) $A \exp(ikz)$

(B) $A \frac{\exp(ikz)}{r}$

(C) $A r \exp(ikz)$

(D) $A \frac{\exp(ikz)}{r^2}$

45. Using WKB approximation, the allowed energies E_n , ($n = 1, 2, 3, \dots$) for a one-dimensional harmonic oscillator are :

(A) $\left(n - \frac{1}{2}\right)\hbar\omega$

(B) $\left(n + \frac{1}{2}\right)\hbar\omega$

(C) $(2n - 1)\hbar\omega$

(D) $(2n + 1)\hbar\omega$

46. Two Stern-Gerlach apparatus S_1 and S_2 are kept along the z -axis with the directions of their magnetic fields along the positive x and y directions respectively. Each apparatus allows only those particles to pass which have their spins aligned in the direction of its magnetic field. If an unpolarised beam of spin $\frac{1}{2}$ particles is made incident on S_1 , the ratio of the intensities $I_i : I_f$ of the initial and final beams is :

(A) 8 : 1 (B) 4 : 1

(C) 1 : 0 (D) 2 : 1

47. For Klein-Gordon equation, the probability current density is given by :

(A) $\frac{i\hbar c}{2m}(\psi\nabla\psi^* - \psi^*\nabla\psi)$

(B) $\frac{i\hbar}{2m}(\psi\nabla\psi^* - \psi^*\nabla\psi)$

(C) $\frac{i\hbar}{2m}(\psi\nabla\psi^* + \psi^*\nabla\psi)$

(D) $\frac{i\hbar}{2mc}(\psi\nabla\psi^* - \psi^*\nabla\psi)$

48. A particle of mass m is confined in an infinite square well with a shelf of height V_0 extending half way across so that :

$$V(x) = \begin{cases} V_0 & \text{for } 0 < x < a/2 \\ 0 & \text{for } \frac{a}{2} < x < a \\ \infty & \text{otherwise} \end{cases}$$

Using WKB approximation, the allowed energies E_n ($n = 1, 2, 3, \dots$) for this particle are, (given $E_n^0 = n^2\pi^2\hbar^2 / 2ma^2$ are the energies of particle in an infinite well with no shelf) :

(A) $E_n^0 + V_0$

(B) $E_n^0 + V_0 / 2$

(C) $E_n^0 + \frac{V_0}{2} \left(1 + \frac{V_0}{4E_n^0}\right)$

(D) $E_n^0 + \frac{V_0}{2} \left(1 + \frac{V_0}{8E_n^0}\right)$

49. In a one-dimensional random walk, the probability of step of unit length in positive direction is $2/3$ and in negative direction is $1/3$. The mean displacement of the walker after n steps is :
- (A) $n/8$ (B) $2n/3$
 (C) $n/3$ (D) 0
50. In a two-state system, one with energy 0 and other with energy $\varepsilon > 0$. The system will have both the levels equally occupied when :
- (A) $T = 0$
 (B) T is infinite
 (C) T is very low
 (D) T is very high
51. A system of three indistinguishable particles has a total energy of 4ε . There are four single particle energy states with energies 0, ε , 2ε and 3ε . The number of microstates accessible to the system will be :
- (A) 4 (B) 1
 (C) 2 (D) 3
52. The temperature T of a blackbody enclosure is doubled, then the total number of photons inside the enclosure increases by a factor of :
- (A) 2 (B) 4
 (C) 8 (D) 16
53. For an adiabatic process involving gas having volume V and temperature T , which of the following is constant (here $\gamma = C_p/C_v$) :
- (A) TV (B) TV^γ
 (C) $TV^{\gamma-1}$ (D) $T^\gamma V$
54. Helmholtz free energy function is defined by :
- (A) $F = U + TS$
 (B) $F = U - TS$
 (C) $F = U + PV$
 (D) $F = U + PV - TS$
55. The Maxwell-Boltzmann distribution holds for :
- (A) distinguishable particles
 (B) all indistinguishable particles
 (C) particles with half integral spin
 (D) particles with integral spin
56. For all the quantum states with energy greater than Fermi energy to be empty in a Fermi-Dirac system, the temperature should be :
- (A) 273 K (B) 373 K
 (C) 0 K (D) 100 K

57. Fluctuation of magnetization M , given as $\Delta M = \frac{\sqrt{\langle M^2 \rangle - \langle M \rangle^2}}{\langle M \rangle}$ for N magnetic moments μ with two allowed orientation $\pm M$ in an external field H at temperature T is :

(A) $\Delta M = \frac{1}{\sqrt{N} \cosh\left(\frac{\mu H}{KT}\right)}$

(B) $\Delta M = \frac{1}{\sqrt{N} \tanh\left(\frac{\mu H}{KT}\right)}$

(C) $\Delta M = 1 / \sqrt{N}$

(D) $\Delta M = \frac{1}{\sqrt{N} \sinh\left(\frac{\mu H}{KT}\right)}$

58. Consider ideal Fermi gas in three dimensions. The density of energy states ε is proportional to :

- (A) $\varepsilon^{1/2}$ (B) $\varepsilon^{-1/2}$
 (C) ε^0 (D) ε^2

59. Consider a system of two Ising spins

S_1 and S_2 taking values ± 1 with interaction energy $E = -JS_1S_2$. For large temperature T , the average energy of the system varies as $C/(k_B T)$ with C given by :

- (A) $-J^2$ (B) $-2J^2$
 (C) J^2 (D) $4J^2$

60. For the following transistor circuit assume $V_{BE} = 0.7V$, $\beta_{dc} = 100$; then the current flowing through R_E is :

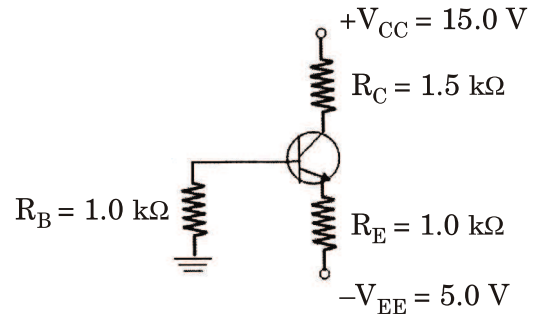

- (A) 4.0 mA
 (B) 8.0 mA
 (C) 4.3 mA
 (D) 3.6 mA

61. For the following differential amplifier circuit, the output voltage V_{out} is :

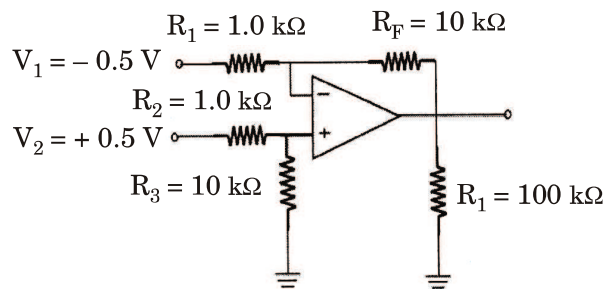

- (A) +10.0 V
 (B) -10.0 V
 (C) -1.0 V
 (D) +1.0 V

62. In the following circuit, the transistor functions as :

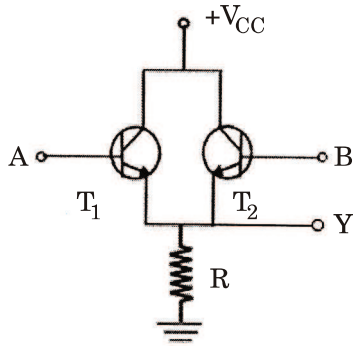

- (A) OR gate (B) AND gate
(C) NOR gate (D) NAND gate

63. Identify the function 'F' generated by the logic network shown below :

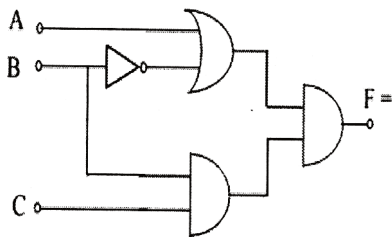

- (A) $F = (A + B) C$
(B) $F = C + B + \bar{B}A$
(C) $F = BC (B + A)$
(D) $F = ABC$

64. The following digital circuit acts as a :

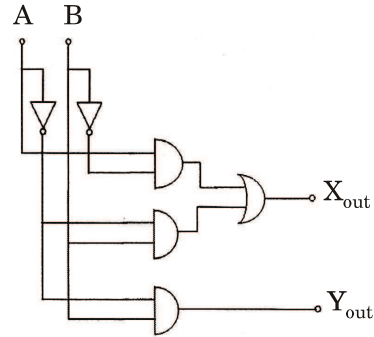

- (A) Half-Subtractor
(B) Half-Adder
(C) Half-Adder/Subtractor
(D) 2's complement Adder/Subtractor

65. For the following diode circuit, the voltage drop across each diode is 0.7 V. The current flowing through the resistor R is

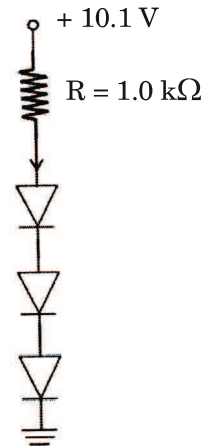

- (A) +10.1 mA (B) -10.1 mA
(C) +8 mA (D) -8 mA

66. When the modulating signal controls the amplitude of a carrier wave, it is known as :
- (A) frequency modulation
 - (B) amplitude modulation
 - (C) phase modulation
 - (D) pulse amplitude modulation
67. A digital multimeter normally uses :
- (A) Flash ADC
 - (B) counter ADC
 - (C) Successive approximation ADC
 - (D) Dual slope ADC
68. Which of the following gauge is used to calibrate gauges employed to measure low pressure of the order of 1.0×10^{-6} torr ?
- (A) Pirani gauge
 - (B) Penning gauge
 - (C) Thermocouple gauge
 - (D) McLeod gauge
69. The difference between the indicated value and true value of a quantity is known as :
- (A) Gross error
 - (B) Absolute error
 - (C) Dynamic error
 - (D) Relative error
70. The ratio of frequencies of the first line of the Lyman series and the first line of the Balmer series is :
- (A) $4/27$ (B) $8/27$
 - (C) $27/5$ (D) $27/8$
71. The number of fundamental vibrational modes of CO_2 molecule is :
- (A) Four : 2 are Raman active and 2 are infrared active
 - (B) Four : 1 is Raman active and 3 are infrared active
 - (C) Three : 1 is Raman active and 2 are infrared active
 - (D) Three : 2 are Raman active and 1 is infrared active

72. A Co^{2+} ion has the spectroscopic term factor :
- (A) ${}^6\text{S}_{5/2}$ (B) ${}^4\text{F}_{3/2}$
 (C) ${}^5\text{D}_0$ (D) ${}^4\text{F}_{5/2}$
73. The coherence length of laser light is :
- (A) directly proportional to the length of the active lasing medium
 (B) inversely proportional to the width of the spectral line
 (C) directly proportional to the width of the spectral line
 (D) inversely proportional to the length of the active lasing medium
74. The g_N value for F^{19} nucleus is 5.256. If it is placed in a magnetic field of strength 1.0 T, the relative population in two spin states at 300 K will be,
 (Given $\mu_N = 5.05 \times 10^{-27} \text{ JT}^{-1}$ and $k = 1.38 \times 10^{-23} \text{ JK}^{-1}$) :
- (A) 1.0 (B) 2.0
 (C) 0.5 (D) 2.5
75. Frank-Condon principle predicts large intensity spectral line for electronic transitions :
- (A) in monoatomic gases
 (B) between the vibrational energy levels of any electronic state
 (C) between the vibrational energy levels of two electronic states of a constant internuclear separation
 (D) between the $v = 0$ vibrational levels of the two electronic states
76. If the average separation between the adjacent lines in the rotational IR spectrum of CO molecule is 3.844 cm^{-1} , then the value of rotational constant is :
- (A) 7.688 cm^{-1}
 (B) 1.922 cm^{-1}
 (C) 3.844 cm^{-1}
 (D) 5.766 cm^{-1}

77. An electron in atomic hydrogen has $g = 2.0032$. In an ESR spectrometer at 9.250 GHz, two lines from the H atom appeared at 353.3 mT and 306.6 mT. The hyperfine coupling constant will be :

- (A) 1.6×10^9 Hz
- (B) 1.6×10^{10} Hz
- (C) 3.2×10^9 Hz
- (D) 3.2×10^{10} Hz

78. Relative intensities of successive lines in the observed Raman spectra of nitrogen molecule is :

- (A) 3 : 4 (B) 1 : 2
- (C) 2 : 3 (D) 1 : 3

79. The D_1 and D_2 lines of sodium (${}^2P_{1/2} \rightarrow {}^2S_{1/2}$ and ${}^2P_{3/2} \rightarrow {}^2S_{1/2}$) will split on application of a weak magnetic field into :

- (A) 3 lines each
- (B) 6 lines each
- (C) 4 lines each
- (D) 4 and 6 lines, respectively

80. The first reflection from FCC crystal is observed at Bragg angle $\theta = 21.5^\circ$, the θ corresponding to the second reflection is :

- (A) 13.5° (B) 18.5°
- (C) 25.0° (D) 36.8°

81. A pair of Li^+ and Cl^- ions, with their radii 0.60 Å and 1.81 Å respectively, touch each other. The attractive force between them is :

- (A) 1.96×10^{-9} N
- (B) 2.96×10^{-9} N
- (C) 3.96×10^{-9} N
- (D) 4.96×10^{-9} N

82. Heat capacity C_v of a metal is measured as a function of temperature T in the low temperature region. Assume that the measured C_v is due to both electronic and lattice contributions, then the plot of (C_v/T) versus T is :
- (A) linear in T
 (B) quadratic in T
 (C) cubic in T
 (D) inversely proportional to T
83. The number of independent elastic constants in an isotropic cubic solid is :
- (A) 1 (B) 2
 (C) 3 (D) 4
84. For an intrinsic semiconductor, m_e^* and m_h^* are respectively the effective masses of electrons and holes near the corresponding band edges. At a finite temperature, the position of the Fermi level :
- (A) depends on m_e^* but not on m_h^*
 (B) depends on m_h^* but not on m_e^*
 (C) depends on both m_e^* and m_h^*
 (D) depends neither on m_e^* nor on m_h^*
85. A solid superconductor of type I is placed in an external magnetic field and is then cooled below its critical temperature. The superconductor :
- (A) retains its magnetic flux because the surface current supports it
 (B) expels out its magnetic flux because it behaves like a paramagnetic material
 (C) expels out its magnetic flux because it behaves like an antiferromagnetic material
 (D) expels out its magnetic flux because the surface current induces a field in the direction opposite to the applied field
86. The dispersion relation for a simple cubic crystal is given by :
- $$E(\vec{k}) = E_0 - 2\beta (\cos k_x a + \cos k_y a + \cos k_z a),$$
- where β is constant having dimension of energy and a is lattice constant. The width of the energy band is :
- (A) 2β (B) 4β
 (C) 8β (D) 12β

87. Consider the energy E in the Brillouin zone as a function of the magnitude of the wave vector \vec{k} for a crystal of lattice constant 'a'. Then :
- (A) the slope of E versus k is proportional to the group velocity
- (B) the slope of E versus k has its maximum value at $|\vec{k}| = \pi / a$
- (C) the plot of E versus k will be parabolic in the interval $-\pi / a < k < \pi / a$
- (D) the slope of E versus k is non-zero for all k in the interval $-\pi / a < k < \pi / a$
88. Eu^{3+} ion has outer electronic configuration $4f^6 5s^2 5p^6$. Its ground state is characterized by one of the following spectroscopic terms :
- (A) 7F_0 (B) ${}^8S_{7/2}$
- (C) 7F_6 (D) ${}^6H_{15/2}$
89. If the static dielectric constant of NaCl crystal is 5.6 and its optical refractive index is 1.5, the ratio of its ionic polarizability to its total polarizability is :
- (A) 0.5 (B) 0.7
- (C) 0.8 (D) 0.9
90. A lattice is characterized by the following primitive vectors $\vec{a} = 2(\hat{i} + \hat{j})$, $\vec{b} = 2(\hat{j} + \hat{k})$, $\vec{c} = 2(\hat{k} + \hat{i})$.
- The reciprocal lattice corresponding to the above is :
- (A) fcc with cube edge 2π
- (B) bcc with cube edge π
- (C) bcc with cube edge 2π
- (D) fcc with cube edge π
91. What is the binding energy per nucleon for isotope $\frac{55}{25} \text{Mn}$?
- (Given : $M_N = 1.008665$ amu, $M_p = 1.007825$ amu, $\frac{55}{25} \text{Mn} = 54.938050$ amu)
- (A) 8.7 MeV (B) 9.2 MeV
- (C) 9.5 MeV (D) 9.9 MeV

92. What should be the energy required, if an electron is used as a probe for studying the nuclear structure, shape and distribution. (Consider nuclear radius is 10^{-13} cm) :
- (A) 0.1 GeV (B) 0.2 GeV
(C) 0.3 GeV (D) 0.4 GeV
93. To penetrate the Coulomb barrier of a light nucleus (${}^1_1\text{H}$), a proton must have a minimum energy of the order of (Consider radius of nucleus $\sim 1\text{Fm}$) :
- (A) 1.44 TeV (B) 1.44 GeV
(C) 1.44 MeV (D) 1.44 KeV
94. What is the energy released in the following nuclear reaction :
- $${}^6_3\text{Li} + {}^2_1\text{H} \rightarrow 2 {}^4_2\text{He} + \text{Q}$$
- (Given : ${}^6_3\text{Li} = 6.01693$ amu,
 ${}^2_1\text{H} = 2.01471$ amu,
 ${}^4_2\text{He} = 4.00388$ amu)
- (A) 11.4 MeV (B) 22.4 MeV
(C) 33.4 MeV (D) 44.4 MeV
95. The quark content of baryon Ξ^0 with strangeness $S = -2$ is given by :
- (A) $u \bar{s} \bar{s}$ (B) $d s s$
(C) $d \bar{s} \bar{s}$ (D) $u s s$
96. Experimentally it is observed that neutron (n)-proton(p) system (deuteron) is bound, but the proton-proton and neutron-neutron systems are not bound. This is due to :
- (A) unequal nuclear force between n - p , n - n and p - p systems
(B) unequal total charges of n - p , n - n and p - p systems
(C) Pauli's principle
(D) non-conservation of angular momentum
97. In the nuclear shell model, orbitals are filled in the following order $1s_{1/2}$, $1p_{3/2}$, $1p_{1/2}$, $1d_{5/2}$, $2s_{1/2}$, $1d_{3/2}$, etc. The splitting between the $p_{3/2}$ and $p_{1/2}$ orbitals is caused by :
- (A) angular momentum of the nucleus
(B) only the spins of the nucleus
(C) spin-orbit coupling of the nucleus
(D) angular momentum and spin of the nucleus

98. Based on the additive quantum numbers such as strangeness (S), baryon number (B), charge (Q), and isospin (I), indicate for which among the four options given below, the following nuclear reaction cannot be induced

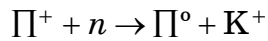

- (A) Q, B, S are conserved, but I_3 is not conserved
- (B) Q and B are conserved, but S and I_3 are not conserved
- (C) Q and I_3 are conserved, but B and S are not conserved
- (D) B, S and I_3 are conserved, but Q is not conserved
99. Parity is not conserved in :
- (A) strong nuclear interactions
- (B) gravitational interactions
- (C) weak interactions
- (D) electromagnetic interactions

100. Parity non-conservation was established in β -decay when it was observed that from polarised Co^{66} nuclei :

- (A) electrons were emitted equally in all directions
- (B) more electrons were emitted in direction opposite to that of magnetic field
- (C) electrons were not emitted in any direction
- (D) more electrons were emitted perpendicular to the direction of magnetic field

MAR - 32223/II—A

ROUGH WORK