

Test Booklet Code & Serial No.

प्रश्नपत्रिका कोड व क्रमांक

**Paper-II**

**ELECTRONIC SCIENCE**

**D**

**Signature and Name of Invigilator**

Seat No.

--	--	--	--	--	--	--	--

1. (Signature) .....

(In figures as in Admit Card)

(Name) .....

Seat No. ....

(In words)

2. (Signature) .....

(Name) .....

OMR Sheet No.

--	--	--	--	--	--	--	--

(To be filled by the Candidate)

**JUN - 38219**

**Time Allowed : 2 Hours]**

**[Maximum Marks : 200**

**Number of Pages in this Booklet : 32**

**Number of Questions in this Booklet : 100**

**Instructions for the Candidates**

- Write your Seat No. and OMR Sheet No. in the space provided on the top of this page.
- This paper consists of 100 objective type questions. Each question will carry two marks. All questions of Paper II will be compulsory.
- At the commencement of examination, the question booklet will be given to the student. In the first 5 minutes, you are requested to open the booklet and compulsorily examine it as follows :
  - To have access to the Question Booklet, tear off the paper seal on the edge of this cover page. Do not accept a booklet without sticker-seal or open booklet.
  - Tally the number of pages and number of questions in the booklet with the information printed on the cover page. Faulty booklets due to missing pages/questions or questions repeated or not in serial order or any other discrepancy should not be accepted and correct booklet should be obtained from the invigilator within the period of 5 minutes. Afterwards, neither the Question Booklet will be replaced nor any extra time will be given. The same may please be noted.
  - After this verification is over, the OMR Sheet Number should be entered on this Test Booklet.
- Each question has four alternative responses marked (A), (B), (C) and (D). You have to darken the circle as indicated below on the correct response against each item.

**Example :** where (C) is the correct response.

A    B    C    D
- Your responses to the items are to be indicated in the **OMR Sheet given inside the Booklet only**. If you mark at any place other than in the circle in the OMR Sheet, it will not be evaluated.
- Read instructions given inside carefully.
- Rough Work is to be done at the end of this booklet.
- If you write your Name, Seat Number, Phone Number or put any mark on any part of the OMR Sheet, except for the space allotted for the relevant entries, which may disclose your identity, or use abusive language or employ any other unfair means, you will render yourself liable to disqualification.
- You have to return original OMR Sheet to the invigilator at the end of the examination compulsorily and must not carry it with you outside the Examination Hall. You are, however, allowed to carry the Test Booklet and duplicate copy of OMR Sheet on conclusion of examination.
- Use only Blue/Black Ball point pen.
- Use of any calculator or log table, etc., is prohibited.
- There is no negative marking for incorrect answers.

**विद्यार्थ्यांसाठी महत्वाच्या सूचना**

- परिक्षार्थींनी आपला आसन क्रमांक या पृष्ठावरील वरच्या कोपऱ्यात लिहावा. तसेच आपणांस दिलेल्या उत्तरपत्रिकेचा क्रमांक त्याखाली लिहावा.
- सदर प्रश्नपत्रिकेत 100 बहुपर्यायी प्रश्न आहेत. प्रत्येक प्रश्नास दोन गुण आहेत. या प्रश्नपत्रिकेतील सर्व प्रश्न सोडविणे अनिवार्य आहे.
- परीक्षा सुरु झाल्यावर विद्यार्थ्यांला प्रश्नपत्रिका दिली जाईल. सुरुवातीच्या 5 मिनीटांमध्ये आपण सदर प्रश्नपत्रिका उघडून खालील बाबी अवश्य तपासून घ्याव्यात.
  - प्रश्नपत्रिका उघडण्यासाठी प्रश्नपत्रिकेवर लावलेले सील उघडावे. सील नसलेली किंवा सील उघडलेली प्रश्नपत्रिका स्विकारू नये.
  - पहिल्या पृष्ठावर नमूद केल्याप्रमाणे प्रश्नपत्रिकेची एकूण पृष्ठे तसेच प्रश्नपत्रिकेतील एकूण प्रश्नांची संख्या पडताळून घ्यावी. पृष्ठे कमी असलेली/कमी प्रश्न असलेली/प्रश्नांचा चुकीचा क्रम असलेली किंवा इतर त्रुटी असलेली सदोष प्रश्नपत्रिका सुरुवातीच्या 5 मिनिटातच पर्यवेक्षकाला परत देऊन दुसरी प्रश्नपत्रिका मागवून घ्यावी. त्यानंतर प्रश्नपत्रिका बदलून मिळणार नाही तसेच वेळही वाढवून मिळणार नाही याची कृपया विद्यार्थ्यांनी नोंद घ्यावी.
  - वरीलप्रमाणे सर्व पडताळून पाहिल्यानंतरच प्रश्नपत्रिकेवर ओ.एम.आर. उत्तरपत्रिकेचा नंबर लिहावा.
- प्रत्येक प्रश्नासाठी (A), (B), (C) आणि (D) अशी चार विकल्प उत्तरे दिली आहेत. त्यातील योग्य उत्तराचा रकाना खाली दर्शविल्याप्रमाणे ठळकपणे काळा/निळ्या करावा.

**उदा. :** जर (C) हे योग्य उत्तर असेल तर.

A    B    C    D
- या प्रश्नपत्रिकेतील प्रश्नांची उत्तरे ओ.एम.आर. उत्तरपत्रिकेतच दर्शवावीत. इतर ठिकाणी लिहिलेली उत्तरे तपासली जाणार नाहीत.
- आत दिलेल्या सूचना काळजीपूर्वक वाचाव्यात.
- प्रश्नपत्रिकेच्या शेवटी जोडलेल्या कोऱ्या पानावरच कच्चे काम करावे.
- जर आपण ओ.एम.आर. वर नमूद केलेल्या ठिकाणा व्यतिरीक्त इतर कोठेही नाव, आसन क्रमांक, फोन नंबर किंवा ओळख पटेल अशी कोणतीही खूण केलेली आढळून आल्यास अथवा असभ्य भाषेचा वापर किंवा इतर गैरमार्गाचा अवलंब केल्यास विद्यार्थ्यांला परीक्षेस अपात्र ठरविण्यात येईल.
- परीक्षा संपल्यानंतर विद्यार्थ्यांने मूळ ओ.एम.आर. उत्तरपत्रिका पर्यवेक्षकांकडे परत करणे आवश्यक आहे. तथापि, प्रश्नपत्रिका व ओ.एम.आर. उत्तरपत्रिकेची द्वितीय प्रत आपल्याबरोबर नेण्यास विद्यार्थ्यांना परवानगी आहे.
- फक्त निळ्या किंवा काळ्या बॉल पेनचाच वापर करावा.
- कॅलक्युलेटर किंवा लॉग टेबल वापरण्यास परवानगी नाही.
- चुकीच्या उत्तरासाठी गुण कपात केली जाणार नाही.

**JUN - 38219/II—D**

## Electronic Science Paper II

**Time Allowed : 120 Minutes]**

**[Maximum Marks : 200**

**Note :** This Paper contains **Hundred (100)** multiple choice questions. Each question carrying **Two (2)** marks. Attempt *All* questions.

- |   |   |
|---|---|
| <p>1. On which of the following principles does Klystron operate ?</p> <p>(A) Amplitude modulation</p> <p>(B) Frequency modulation</p> <p>(C) Pulse modulation</p> <p>(D) Velocity modulation</p> <p>2. DSO cannot be used for :</p> <p>(A) Signal analysis</p> <p>(B) Signal monitoring</p> <p>(C) Signal digitisation</p> <p>(D) Signal generation</p> <p>3. Duplexer in RADAR system is :</p> <p>(A) An oscillator</p> <p>(B) Microwave switch</p> <p>(C) An amplifier</p> <p>(D) Active filter</p> <p>4. Which of the following is the Poisson's equation ?</p> <p>(A) <math>\nabla^2 V = - \rho/\epsilon</math></p> <p>(B) <math>\nabla^2 V = - 4\pi\sigma</math></p> <p>(C) <math>\nabla^2 V = - 4\pi\rho</math></p> <p>(D) <math>\nabla^2 V = 0</math></p> | <p>5. The Health status of functioning heart is recorded as ECG, which is represented as :</p> <p>(A) Current in <math>\mu\text{A}</math></p> <p>(B) DC voltage in mV</p> <p>(C) Pulsed waveform of micro volt</p> <p>(D) High frequency signal</p> <p>6. Match List-I with List-II :</p> <p style="text-align: center;"><b>List-I : Number on Display</b></p> <p>(a) 1072</p> <p>(b) 893</p> <p>(c) 132</p> <p>(d) 59705</p> <p style="text-align: center;"><b>List-II : ADC</b></p> <p>(i) 8-bit</p> <p>(ii) 10-bit</p> <p>(iii) 12-bit</p> <p>(iv) 16-bit</p> <p><b>Codes :</b></p> <p>(a) (b) (c) (d)</p> <p>(A) (iii) (i) (ii) (iv)</p> <p>(B) (iii) (ii) (i) (iv)</p> <p>(C) (iv) (i) (ii) (iii)</p> <p>(D) (i) (ii) (iii) (iv)</p> |
|---|---|

7. The dominant mode of a rectangular wave guide is :

- (A)  $TE_{11}$
- (B)  $TE_{12}$
- (C)  $TE_{10}$
- (D)  $TE_{21}$

8. Arrange the following microwave frequency bands on increasing order of frequency :

- (i) L Band
  - (ii) S Band
  - (iii) C Band
  - (iv) X Band
- (A) (iii), (i), (iv), (ii)
  - (B) (iv), (iii), (ii), (i)
  - (C) (ii), (iii), (iv), (i)
  - (D) (i), (ii), (iii), (iv)

9. Match the following lists :

**List I**

- (a) Tunnel diode
- (b) Gunn diode
- (c) Reflex klystron
- (d) TRAPATT

**List II**

- (i) Negative Resistance
- (ii) Two cavity
- (iii) Oscillator
- (iv) Low noise oscillator

**Codes :**

- (a) (b) (c) (d)
- (A) (i) (iii) (iv) (ii)
- (B) (i) (iii) (ii) (iv)
- (C) (i) (ii) (iii) (iv)
- (D) (iv) (i) (ii) (iii)

10. Assertion-Reason type questions :

**Assertion (A) :**

Electromagnetic waves are transverse in nature.

**Reason (R) :**

The electric and magnetic fields are perpendicular to the direction of wave propagation.

- (A) Both (A) and (R) are true and (R) is the correct explanation of (A)
- (B) Both (A) and (R) are true but (R) is not correct explanation of (A)
- (C) (A) is true but (R) is false
- (D) (A) is false and (R) is true

11. An AM signal is detected using an envelope detector. The carrier frequency and modulating signal frequency are 2 MHz and 1 kHz respectively. An appropriate value for the time constant of the envelope detector is :

- (A) 2000  $\mu\text{s}$
- (B) 0.050  $\mu\text{s}$
- (C) 100  $\mu\text{s}$
- (D) 200  $\mu\text{s}$

12. Which of the following is *not* the MEMS application ?

- (A) Impact sensor in air bags
- (B) Face detection
- (C) Hall effect proximity sensor
- (D) Accelerometer

13. A frame in video transmission system has  $800 \times 400$  pixel grid with 64 intensity levels per pixel. The transmission system transmit 360 picture frames per second. The data rate of the system is :
- (A) 1382.4 Mb/s
  - (B) 3686 Mb/s
  - (C) 691.2 Mb/s
  - (D) 7372 Mb/s
14. Receiver without automatic gain control is tuned to a strong station, the signal may ..... the later IF and AF stage.
- (A) Cut-off
  - (B) Overload
  - (C) Underload
  - (D) Cut-in
15. An eye diagram is an oscilloscope display in which the ..... is synchronized to the ..... .
- (A) Bit rate, intensity base
  - (B) Intensity base, time base
  - (C) Time base, bit rate
  - (D) Bit rate, time base
16. Three sinusoidal signals 2400 Hz, 1200 Hz and 800 Hz are sampled at their respective Nyquist rates, these are encoded with 8 bit words and time division multiplexed. The bit rate for the multiplexed signal is :
- (A) 35.2 kb/s
  - (B) 105.6 kb/s
  - (C) 352 kb/s
  - (D) 10.56 kb/s

17. In frequency shift keying :

- (a) The combined signal in FSK modulator generated from two separate oscillators cannot have discontinuities in amplitude.
- (b) The combined signal in FSK modulator generated from two separate oscillators cannot have discontinuities in phase.
- (c) The combined signal in FSK modulator generated from single oscillator method can have discontinuities in amplitude.
- (d) The combined signal in FSK modulator generated from single oscillator method cannot have discontinuities in amplitude.

**Options :**

- (A) (b) and (d)
- (B) (a) and (d)
- (C) (d) only
- (D) (a) and (c)

18. Match List I with List II and select the *correct* answer using codes given below :

**List I**

- (a) DSB-SC modulation
- (b) Amplitude modulation
- (c) Frequency modulation
- (d) Phase modulation

**List II**

- (i)  $A \sin (\omega_c t + k \int_{-\infty}^t m(z) dz)$
- (ii)  $A \sin (\omega_c t + k_m(t))$
- (iii)  $k.m(t) A \sin (\omega_c t)$
- (iv)  $\{1 + k_m(t)\} A \sin (\omega_c t)$

**Codes :**

- (a) (b) (c) (d)
- (A) (iv) (i) (iii) (ii)
- (B) (iii) (iv) (i) (ii)
- (C) (iii) (i) (ii) (iv)
- (D) (iv) (iii) (i) (ii)

19. The main difference between the thermal noise and shot noise is that :

- (A) Mean square noise component is dependent noise bandwidth in shot and thermal noise
- (B) Mean noise component is zero in both
- (C) Shot noise non-uniform spectrum in high microwave frequency range
- (D) Shot noise and thermal noise is temperature dependent

20. Which of the following technologies is associated with IOT implementation ?

- (A) High power drivers
- (B) Big data analytics
- (C) LTCC
- (D) Cryogenics

21. Find maximum operating/switching frequency of a converter grade SCR whose turn on time and turn off time are  $50 \mu\text{s}$  and  $150 \mu\text{s}$  respectively.

- (A) 20 kHz
- (B) 10 kHz
- (C) 5 kHz
- (D) 2 kHz



22. For the following DIAC triggered circuit the pattern of the current trigger pulses at gate ( $I_G$ ) will be :

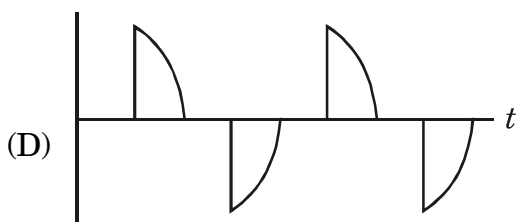
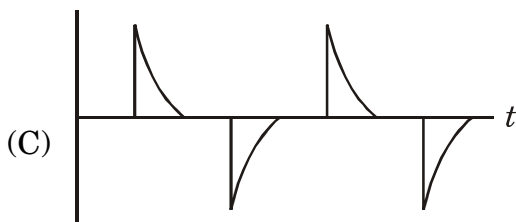
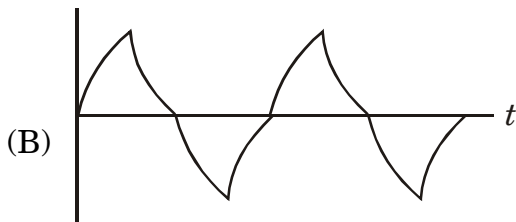
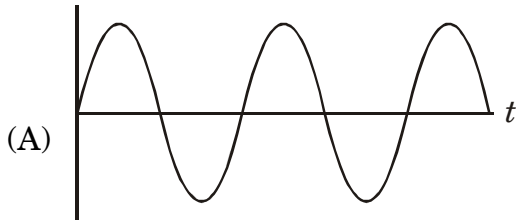
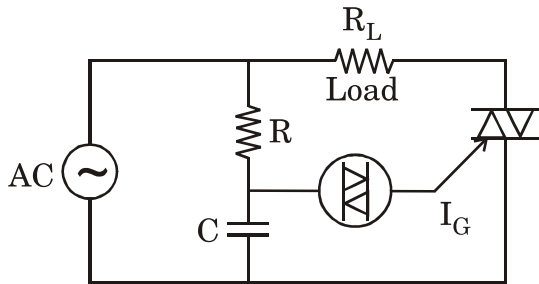

23. In thyristor circuits to isolate control part from power section the following method of coupling is used :

- (A) Pulse transformer
- (B) High voltage capacitor
- (C) Specialized RC section
- (D) High speed relay

24. Field breakdown voltage for silicon used in power devices is :

- (A) 100 kV/cm
- (B) 300 kV/cm
- (C) 1 MV/cm
- (D) 10 MV/cm

25. In two transistor analogy of a thyristor, if ' $\alpha$ ' is current gain and  $I_{CBO}$  is the collector leakage current, the expression for anode current ' $I_A$ ' is given by :

(A) 
$$I_A = \frac{\alpha_1 I_G + I_{CBO1} - I_{CBO2}}{1 - (\alpha_1 + \alpha_2)}$$

(B) 
$$I_A = \frac{\alpha_1 I_G + I_{CBO1} + I_{CBO2}}{1 + (\alpha_1 + \alpha_2)}$$

(C) 
$$I_A = \frac{\alpha_2 I_G + I_{CBO2} + I_{CBO1}}{1 - (\alpha_1 - \alpha_2)}$$

(D) 
$$I_A = \frac{\alpha_2 I_G + I_{CBO1} + I_{CBO2}}{1 - (\alpha_1 + \alpha_2)}$$

26. The following light source has the best directivity :

- (A) Burrus LED
- (B) Edge emitting LED
- (C) Surface emitting LED
- (D) Double Heterojunction LED

27. The following technique is best suited for low cost optical fibers :

- (A) VAD
- (B) OVD
- (C) MCVD
- (D) Double crucible

28. The following optical fiber has no effect of impurity in the axis region in its transmission properties :

- (A) Graded index fiber
- (B) Single mode fiber
- (C) Step index multimode fiber
- (D) Plastic cladded silica fiber

29. In a four level laser system :

- (A) There are four blocks in the laser system
- (B) Power levels are very high
- (C) Lower lasing level empty
- (D) Pumping power is designed with four stages

30. Match the following :

**Set I**

- (a) Line width
- (b) Directionality
- (c) Energy
- (d) Quality factor

**Set II**

- (i) Wavelength
- (ii) Coherence
- (iii) Energy stored
- (iv) Scattering

**Codes :**

- |     |      |       |      |       |
|-----|------|-------|------|-------|
|     | (a)  | (b)   | (c)  | (d)   |
| (A) | (i)  | (iii) | (ii) | (iv)  |
| (B) | (iv) | (iii) | (i)  | (ii)  |
| (C) | (i)  | (iv)  | (ii) | (iii) |
| (D) | (ii) | (iv)  | (i)  | (iii) |

**Q. No. 31 - 35 :**

The static characteristics of an instrument are, in general, considered for instruments which are used to measure an unvarying process condition. All the static performance characteristics are obtained by one form or another of a process called calibration. There are a number of related definitions (or characteristics), which are described below, such as accuracy, precision, repeatability, resolution errors, sensitivity, etc.

- (1) **Instrument** : A device or mechanism used to determine the present value of the quantity under measurement.
- (2) **Measurement** : The process of determining the amount, degree, or capacity by comparison (direct or indirect) with the accepted standards of the system units being used.
- (3) **Accuracy** : The degree of exactness (closeness) of a measurement compared to the expected (desired) value.

- (4) **Resolution** : The smallest change in a measured variable to which an instrument will respond.
- (5) **Precision** : A measure of the consistency or repeatability of measurements *i.e.*, successive readings do not differ. (Precision is the consistency of the instrument output for a given value of input).
- (6) **Expected value** : The design value *i.e.*, the most probable value that calculations indicate one should expect to measure.
- (7) **Error** : The deviation of the true value from the desired value.
- (8) **Sensitivity** : The ratio of the change in output (response) of the instrument to a change of input or measured variable.
31. Which of the following is *not* an instrument ?
- (A) Fuel gauge in motorbike  
(B) Meter scale  
(C) PID controller  
(D) Wrist watch
32. Which of the following is most accurate device for length measurement ?
- (A) Odometer  
(B) Calorimeter  
(C) Micrometer  
(D) Vernier calipers
33. Which of the following instruments has highest resolution ?
- (A) Electrometer  
(B) Micro-ammeter  
(C) 6½ digit multimeter  
(D) Galvanometer

34. Which of the following has very low precession ?
- (A) Mercury thermometer
  - (B) PTC thermometer
  - (C) Thermistor gauge
  - (D) Pyroelectric gauge
35. Which of the following is highly sensitive transducer ?
- (A) Photodiode
  - (B) Potentiometer
  - (C) Thermocouple
  - (D) Thermistor
36. Transient analysis in a control system means :
- (A) Subjecting a system for short duration of period
  - (B) Applying high voltage momentarily
  - (C) Analysing system with infinite frequency spectrum
  - (D) A mathematical tool
37. Derivative control is desirable in a system in which :
- (A) Output goes to steady state below the set level
  - (B) Value of the controlled variable changes rapidly
  - (C) Environmental variables play higher role
  - (D) Cost effective design is necessary
38. The following is an example for closed loop system :
- (A) Room fan
  - (B) Air cooler
  - (C) Laboratory soldering iron
  - (D) Refrigerator

39. In a control system, what is the percentage error in measurement if the variable range is 4.20 mA and the measured value is 13 mA with set point of 10 mA :

- (A) 18.75
- (B) 20.50
- (C) 24.00
- (D) 28.75

40. Disadvantage of an electronic control system is :

- (A) Large current requirement
- (B) Expensive
- (C) Susceptible to fire risk
- (D) Varies with seasonal changes

41. Which of the following compounds is *not* suitable for Light Emitting Diodes (LEDs) ?

- (A) GaN
- (B) GaP
- (C) SiCa
- (D) GaAs

42. The distribution coefficient  $K_d$  is given by

$$K_d = \frac{C_S}{C_L}$$

where  $C_S$  = Concentration of impurity in the solid

$C_L$  = Concentration in the liquid

Which of the following is *not* a function of  $K_d$  ?

- (A) Growth rate
- (B) The impurity concentration
- (C) The temperature of the solid-liquid interface
- (D) The orientation of the material

43. Ebers-Moll model of BJT has two coupled back to back diodes in parallel with controlled current sources.

Which of the following is/are *correct* for switching applications ?

- (1) If two diodes are both in forward bias, then the BJT is in a low impedance state.
- (2) If two diodes are both in reverse bias, then BJT is in a high impedance state.
- (3) If two diodes are both in forward bias, then the BJT is in high impedance state.
- (4) If two diodes are both in reverse bias, then BJT is in low impedance state.

- (A) 1 and 2
- (B) 2 and 4
- (C) 1, 2 and 3
- (D) 2, 3 and 4

44. The technique of growing an oriented single crystal layer on a substrate wafer is called :

- (A) Oxidation
- (B) Ion-implantation
- (C) Epitaxy
- (D) Diffusion

45. Determine the values of current amplification factor ( $\beta$ ) of two different transistors having  $\alpha_1 = 0.99$  and  $\alpha_2 = 0.98$  :

- (A) 99 and 98 respectively
- (B) 49 and 99 respectively
- (C) 99 and 49 respectively
- (D) 98 and 99 respectively

46. When the applied voltage across the PN junction is less than zero, then :

- (A) Energy barrier between P and N junction becomes small
- (B) Drift current flow is favourable
- (C) Diffusion current flow is favourable
- (D) Drift current flow is not favourable

47. Band gap of  $\text{SiO}_2$  in electron volt is :

- (A) 1.12 eV
- (B) 1.42 eV
- (C) 5 eV
- (D) 8 eV

48. The tunnel diode is useful in microwave oscillators and amplifiers because of the following reasons :

- (A) Because it is lightly doped as compared to PN junction diode.
- (B) Because it absorbs power.
- (C) Because it exhibits a negative resistance characteristic in the region between peak current  $I_P$  and valley current  $I_V$ .
- (D) Because it exhibits a positive resistance characteristic in the region between peak current  $I_P$  and valley current  $I_V$ .

49. Identify which one of the following materials *cannot* be used for the gate electrode in a MOSFET ?

- (A) Aluminium
- (B) Tungsten
- (C) Gold
- (D) Hafnium dioxide



50. Match List-I with List-II :

**List I**

- (a) Drift current
- (b) Diffusion current
- (c)  $I_D \approx I_S e^{\frac{qV_D}{\eta kT}}$
- (d)  $I_D \approx - I_S$

**List II**

- (1) Ideal current when  $V_D$  is negative
- (2) A current when there is an electric field
- (3) A current when there is concentration difference for either the electrons or holes or both
- (4) Ideal current when  $V_D$  is positive

**Codes :**

- (a) (b) (c) (d)
- (A) (1) (2) (3) (4)
- (B) (2) (3) (4) (1)
- (C) (3) (4) (1) (2)
- (D) (2) (3) (1) (4)

51. Find the short circuit current ( $I_{S.C.}$ ) of the following circuit using Norton's theorem :

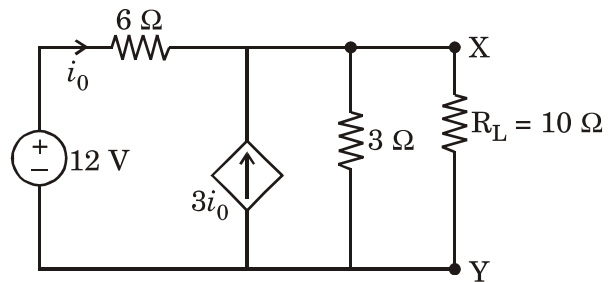

- (A) 4 A
- (B) 2.5 A
- (C) 8 A
- (D) 6 A

52. A two port network is a rectangular box that represents a network consisting of :

- (A) Two pairs of ports
- (B) Two pairs of terminals
- (C)  $n$ -pairs of ports
- (D) Two terminals

53. An ideal filter is the one which has :

- (A) Zero attenuation in the pass band
- (B) Zero attenuation in the reject band
- (C) Infinite attenuation in the pass band
- (D) Finite attenuation in the reject band

54. If a network contains B branches and N nodes, then the number of mesh current equations would be :

- (A)  $B - (N - 1)$
- (B)  $N - (B - 1)$
- (C)  $B - N - 1$
- (D)  $(B + N) - 1$

55. A power factor of 1 indicates a :

- (A) Purely resistive element
- (B) Purely resistive circuit
- (C) Purely reactive element
- (D) Purely reactive circuit

56. The Laplace transform of first derivative of function  $f(t)$  is :

- (A)  $F(s)/s$
- (B)  $sF(s) - f(0)$
- (C)  $F(s) - f(0)$
- (D)  $f(0)$

57. State variable analysis is *not* applicable to which of the following circuits ?

- (A) A circuit consisting of resistors only
- (B) A circuit with resistors and capacitors
- (C) A circuit with capacitors and inductors
- (D) A RLC circuit

58. What is the phase angle of a series RLC circuit at resonance ?

- (A) Zero
- (B)  $90^\circ$
- (C)  $45^\circ$
- (D)  $30^\circ$

59. A function is said to be even if :

- (A)  $f(t) = -f(-t)$
- (B)  $f(t) = f(-t)$
- (C)  $f(t) = -f\left[t - \frac{T_0}{2}\right]$
- (D)  $f(t) = -f(t)$

60. A superposition theorem is valid for which of the following ?

- (A) Resistors with voltage sources
- (B) Resistors with diodes
- (C) Resistors with transistors
- (D) Resistors with zener diodes

61. Peak inverse voltage of diodes in bridge rectifier is normally ..... times that of diodes in full wave rectifier with centre tap transformer.

- (A) 3
- (B) 2
- (C) 0.5
- (D) 1

62. Load regulation of a regulated power supply must be :

- (A) As high as possible
- (B) Varying with load impedance
- (C) As low as possible
- (D) Fixed to some intermediate value

63. For a 3-stage amplifier having gains of 5 dB, 10 dB and 15 dB respectively, the overall gain would be :

- (A) 750 dB
- (B) 15 dB
- (C) 25 dB
- (D) 30 dB

64. An amplifier having open loop gain of 100 is provided with a negative feedback having feedback factor of 0.02. The gain of the amplifier after feedback will be :

- (A) 50.00
- (B) 33.33
- (C) 60.72
- (D) 21.89

65. The number of harmonics in addition to base frequency present in the output of a tuned oscillator are :

- (A) 5
- (B) 2
- (C) 0
- (D) 1

66. The output of the following circuit will be :

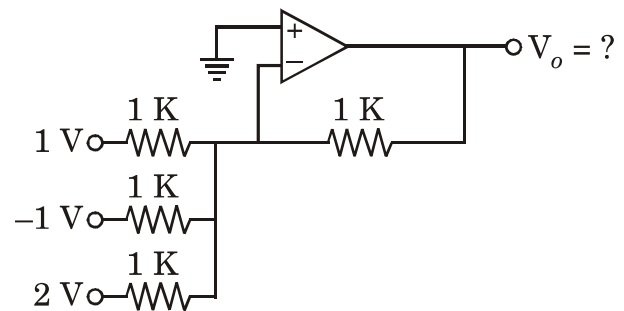

- (A) 2 V
- (B) 0 V
- (C) - 1 V
- (D) 1 V

67. Which of the following is *not* true in case of phase locked loop ?

- (A) The phases of input and VCO are matched
- (B) The frequency of input and VCO are same
- (C) The VCO frequency tracks the input
- (D) The VCO input is always zero when locked

68. Arrange the following semiconductor devices in increasing order of number of  $p-n$  junctions :

- (i) diode
- (ii) mosfet
- (iii) bjt
- (iv) scr

**Codes :**

- (A) (ii), (i), (iii), (iv)
- (B) (i), (ii), (iii), (iv)
- (C) (iii), (ii), (i), (iv)
- (D) (iii), (ii), (iv), (i)

69. Match List-I with List-II :

**List-I**

- (a) Active filters
- (b) Multivibrators
- (c) Schmitt trigger
- (d) Voltage regulator

**List-II**

- (i) Hysteris
- (ii) dc output
- (iii) Pulse/Pulse train
- (iv) R-C network with OP-Amp.

**Codes :**

- (a) (b) (c) (d)
- (A) (i) (ii) (iii) (iv)
- (B) (iv) (iii) (i) (ii)
- (C) (iv) (iii) (ii) (i)
- (D) (iii) (ii) (i) (iv)

70. **Assertion (A) :**

An oscillator is basically multivibrator with feedback.

**Reason (R) :**

R-C combination is used for low or high pass filtering.

(A) Both (A) and (R) are true and

(R) is correct explanation of (A)

(B) Both (A) and (R) are true and (R)

is not correct explanation of (A)

(C) (A) is true and (R) is false

(D) (A) is false and (R) is true

71. The *correct* circuit of a Half Adder is :

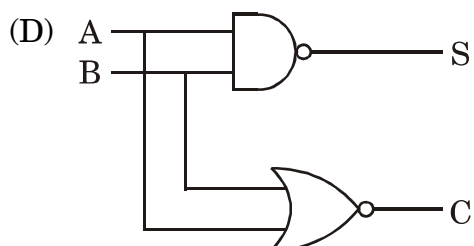
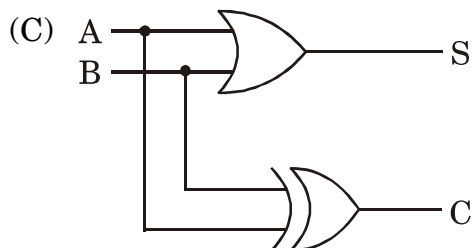
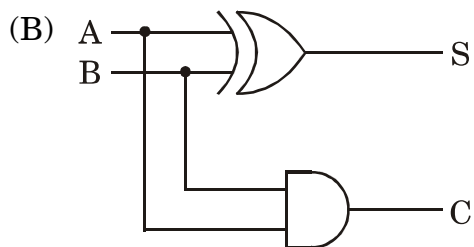
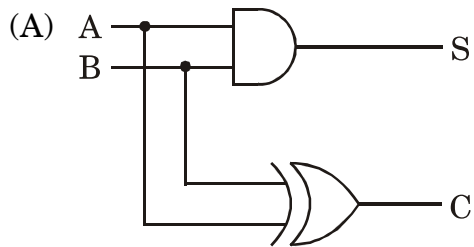

72. A 16-bit presetable counter with 1 MHz clock input can be used to generate delay in the range of :

- (A) 0 to 64 mS with 1  $\mu$ S resolution
- (B) 16  $\mu$ S with 1  $\mu$ S resolution
- (C) 6400  $\mu$ S with 1 mS resolution
- (D) 16 mS with 1 mS resolution

73. Address and Data lines required to access 32 kB, byte organised memory will be :

- (A) 12 and 8
- (B) 13 and 8
- (C) 32 and 1
- (D) 15 and 8

74. An ADC used in  $3\frac{1}{2}$  (Three and half) digital multimeter is generally :

- (A) 12 bit dual slope
- (B) 8-bit successive approximation
- (C) 8-bit flash
- (D) 8-bit dual slope

75. A state equation specifies :

- (A) Next state as a function of present state and inputs
- (B) Clock applied
- (C) Behaviour of a combinational circuit
- (D) Number of arithmetic operations

76. An 8-bit DAC is used to control a linear valve with a 0 to 5 volt signal. The valve is fully open if the signal is 5 volts and closed if signal is 0 volt. An approximate resolution of the DAC in terms of volts and percentage of valve opening will be :

- (A) 0.02 V and 0.4%
- (B) 0.01 V and 10%
- (C) 0.1 V and 10%
- (D) 0.02 V and 4%

77. Decimal to BCD priority encoder, 74147 will have :

- (A) 8 inputs and 4 outputs
- (B) 10 inputs and 8 outputs
- (C) 10 inputs and 4 outputs
- (D) 8 inputs and 8 outputs

78. What does the following HDL

statement mean ?

wire [7 : 0] data-a;

(A) data-a is an 8-bit wire and the

msb is bit 7

(B) data-a is a 4-bit wire and the

msb is bit 7

(C) data-a is a 4-bit wire and the

lsb is bit 7

(D) data-a is a 8-bit wire and the

lsb is bit 7

79. Match the List-I with List-II and select the *correct* answer using the codes given below the lists :

**List-I**

- (a) ALU
- (b) Parity checker
- (c) Shift register
- (d) DRAM

**List-II**

- (i) EXOR-Gate
- (ii) Full adder
- (iii) MOS Transistor
- (iv) DFF

**Codes :**

- (a) (b) (c) (d)
- (A) (iii) (iv) (i) (ii)
- (B) (ii) (iii) (iv) (i)
- (C) (ii) (iv) (iii) (i)
- (D) (ii) (i) (iv) (iii)



80. **Assertion (A) :**

Universal shift register can be used to implement accumulator.

**Reason (R) :**

Addition and subtraction can be realised using shift registers.

(A) Both (A) and (R) are true and (R) is the correct explanation of (A).

(B) Both (A) and (R) are true but (R) is not the correct explanation of (A).

(C) (A) is true but (R) is false.

(D) (A) is false and (R) is true.

81. Microcontroller 8051 operates with 12 MHz oscillator and one machine cycle is defined as 12 oscillator periods. The execution time for a 4 machine cycle instruction would therefore be :

(A) 4  $\mu$ s

(B) 8  $\mu$ s

(C) 1  $\mu$ s

(D) 2  $\mu$ s

82. 8086 works in multiprocessing mode with the help of :

(A) Virtual memory

(B) DMA mode

(C) Max mode

(D) Minimum mode

83. Which of the following special function registers of 8051 is *not* bit addressible ?
- (A) Accumulator (ACC)
  - (B) Program Status Word (PSW)
  - (C) Port 0 (PO)
  - (D) Serial Data Buffer (SBUF)
84. The fastest I/O data transfer uses :
- (A) Polled I/O
  - (B) Interrupt driven I/O
  - (C) Memory mapped I/O
  - (D) DMA
85. MUL A, B instruction of micro-controller 8051 needs :
- (A) 4 machine cycles
  - (B) 2 machine cycles
  - (C) 1 machine cycle
  - (D) 3 machine cycles
86. If the contents of code segment register of 8086 is 1000H and the instruction pointer is loaded with 0134H, then the instruction will be fetched from :
- (A) 10000H
  - (B) 0134H
  - (C) 10134H
  - (D) 1134H
87. Vector addresses of 8051 interrupts are located in :
- (A) On-chip RAM
  - (B) 0000-0023H
  - (C) 0001-1000H
  - (D) External memory

88. The *correct* sequence of execution of Read/Write instruction in 8086 Min mode of operation is :

- (A) Set  $\overline{MN/\overline{MX}}$  high, Output high on  $M/\overline{IO}$ , Set ALE, Transfer data
- (B) Set  $\overline{MN/\overline{MX}}$  low, Output high on  $M/\overline{IO}$ , Transfer data, Set ALE
- (C) Output high on  $M/\overline{IO}$ , Transfer data, Set ALE, Set  $\overline{MN/\overline{MX}}$  high
- (D) Transfer data, Set ALE, Set  $\overline{MN/\overline{MX}}$  high, Output high on  $M/\overline{IO}$

89. Match List-I with List-II :

**List I : Register**

- (a) IP
- (b) CX
- (c) SI
- (d) SP

**List II : Use**

- (i) Loop operations
- (ii) String manipulation
- (iii) Modular programming
- (iv) Code access

**Codes :**

- (a) (b) (c) (d)
- (A) (iv) (ii) (iii) (i)
- (B) (ii) (i) (iii) (iv)
- (C) (iv) (i) (ii) (iii)
- (D) (i) (iii) (ii) (iv)

90. **ASSERTION (A) :**

LCALL adder16 calls a subroutine located at the indicated address.

**REASON (R) :**

The execution of LCALL results in putting the 16-bit address on the stack.

- (A) Both (A) and (R) are true and (R) is the correct explanation of (A)
- (B) Both (A) and (R) are true but (R) is not the correct explanation of (A)
- (C) (A) is true but (R) is false
- (D) (A) is false but (R) is true

91. Identify the ordered processing steps in fabrication of integrated circuits :

- (A) Diffusion, Oxidation, Chemical vapour deposition, Photolithography, Metallization
- (B) Oxidation, Diffusion, Chemical vapour deposition, Photolithography, Metallization
- (C) Chemical vapour deposition, Oxidation, Diffusion, Photolithography, Metallization
- (D) Diffusion, Oxidation, Photolithography, Chemical vapour deposition, Metallization

92. In nMOS device, gate material could be :

- (A) Silicon
- (B) Polysilicon
- (C) Boron
- (D) Phosphorus

93. Which of the following *cannot* be obtained from an X-ray crystallography study ?

- (A) Packing arrangements
- (B) Spacing between two parallel atomic rings
- (C) Vibration frequency of a carbonyl group
- (D) Geometry of hydrogen bonding

94. Most of the VLSI foundries specify Design Rule files. These design rules however do not specify :

- (A) Line widths
- (B) Interpattern separations
- (C) Layer colours
- (D) Pattern extensions

95. In CMOS logic circuits the *p*-MOS transistor acts as :

- (A) Pull-down network
- (B) Pull-up network
- (C) Short to ground
- (D) Load

96. The circuit diagram shown in figure represents :

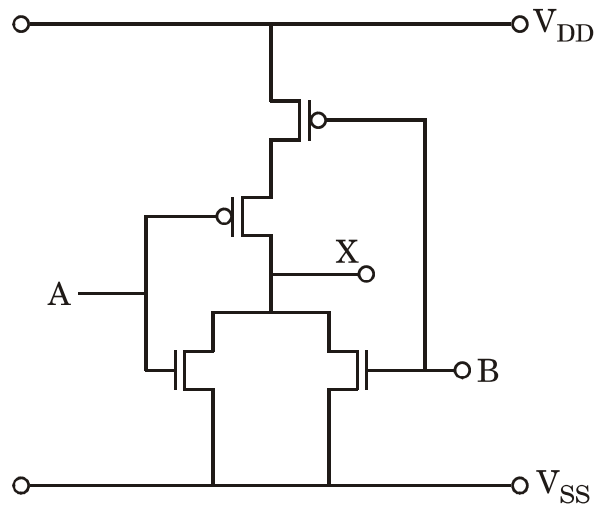

- (A) Two input CMOS AND gate
- (B) Two input CMOS NAND gate
- (C) Two input CMOS NOR gate
- (D) Two input CMOS OR gate

97. The Fast Fourier Transform algorithm exploits properties of the twiddle factor :

- (A) Symmetry and periodicity
- (B) Convolution and correlation
- (C) Linearity and causality
- (D) Asymmetry and linearity

98. **ASSERTION (A)** : Epitaxy refers to the deposition of a crystalline overlayer on a crystalline substrate.

**REASON (R)** : An epitaxial layer cannot be doped during growth phase.

- (A) Both (A) and (R) are true and (R) is correct explanation of (A)
- (B) Both (A) and (R) are true but (R) is not correct explanation of (A)
- (C) (A) is true but (R) is false
- (D) (A) and (R) both are false

99. Match List-I with List-II :

**List-I**

- (a) Gate conductor
- (b) Masking impurity diffusion
- (c) Isolation method
- (d) Layout planning

**List-II**

- (i) SiO<sub>2</sub> layer
- (ii) Polysilicon
- (iii) Stick diagram
- (iv) Trench oxidation (LOCOS)

**Codes :**

- (a) (b) (c) (d)
- (A) (ii) (iii) (iv) (i)
- (B) (iii) (i) (ii) (iv)
- (C) (iv) (i) (ii) (iii)
- (D) (ii) (i) (iv) (iii)

100. Identify the *correct* sequence for implementing sensors in IOT :

- (A) Data acquisition, conversion, sensing and communication
- (B) Sensing, data acquisition, conversion and communication
- (C) Sensing, conversion, data acquisition and communication
- (D) Sensing, conversion, communication and data acquisition

**JUN - 38219/II—D**

**ROUGH WORK**

**JUN - 38219/II—D**

**ROUGH WORK**