

Test Booklet Code & Serial No.

प्रश्नपत्रिका कोड व क्रमांक

Paper-II

A

COMPUTER SCIENCE AND APPLICATIONS

Signature and Name of Invigilator

Seat No.

--	--	--	--	--	--	--	--

1. (Signature)

(In figures as in Admit Card)

(Name)

Seat No.

(In words)

2. (Signature)

(Name)

OMR Sheet No.

--	--	--	--	--	--	--	--

(To be filled by the Candidate)

JUN - 37219

Time Allowed : 2 Hours]

[Maximum Marks : 200

Number of Pages in this Booklet : 32

Number of Questions in this Booklet : 100

Instructions for the Candidates

- Write your Seat No. and OMR Sheet No. in the space provided on the top of this page.
- This paper consists of 100 objective type questions. Each question will carry two marks. All questions of Paper II will be compulsory.
- At the commencement of examination, the question booklet will be given to the student. In the first 5 minutes, you are requested to open the booklet and compulsorily examine it as follows :
 - To have access to the Question Booklet, tear off the paper seal on the edge of this cover page. Do not accept a booklet without sticker-seal or open booklet.
 - Tally the number of pages and number of questions in the booklet with the information printed on the cover page. Faulty booklets due to missing pages/questions or questions repeated or not in serial order or any other discrepancy should not be accepted and correct booklet should be obtained from the invigilator within the period of 5 minutes. Afterwards, neither the Question Booklet will be replaced nor any extra time will be given. The same may please be noted.
 - After this verification is over, the OMR Sheet Number should be entered on this Test Booklet.
- Each question has four alternative responses marked (A), (B), (C) and (D). You have to darken the circle as indicated below on the correct response against each item.
Example : where (C) is the correct response.

<input type="radio"/>	<input type="radio"/>	<input checked="" type="radio"/>	<input type="radio"/>
A	B	C	D
- Your responses to the items are to be indicated in the **OMR Sheet given inside the Booklet only**. If you mark at any place other than in the circle in the OMR Sheet, it will not be evaluated.
- Read instructions given inside carefully.
- Rough Work is to be done at the end of this booklet.
- If you write your Name, Seat Number, Phone Number or put any mark on any part of the OMR Sheet, except for the space allotted for the relevant entries, which may disclose your identity, or use abusive language or employ any other unfair means, you will render yourself liable to disqualification.
- You have to return original OMR Sheet to the invigilator at the end of the examination compulsorily and must not carry it with you outside the Examination Hall. You are, however, allowed to carry the Test Booklet and duplicate copy of OMR Sheet on conclusion of examination.
- Use only Blue/Black Ball point pen.
- Use of any calculator or log table, etc., is prohibited.
- There is no negative marking for incorrect answers.

विद्यार्थ्यांसाठी महत्वाच्या सूचना

- परिक्षार्थींनी आपला आसन क्रमांक या पृष्ठावरील वरच्या कोपऱ्यात लिहावा. तसेच आपणांस दिलेल्या उत्तरपत्रिकेचा क्रमांक त्याखाली लिहावा.
- सदर प्रश्नपत्रिकेत 100 बहुपर्यायी प्रश्न आहेत. प्रत्येक प्रश्नास दोन गुण आहेत. या प्रश्नपत्रिकेतील सर्व प्रश्न सोडविणे अनिवार्य आहे.
- परीक्षा सुरु झाल्यावर विद्यार्थ्यांला प्रश्नपत्रिका दिली जाईल. सुरुवातीच्या 5 मिनीटांमध्ये आपण सदर प्रश्नपत्रिका उघडून खालील बाबी अवश्य तपासून पहाव्यात.
 - प्रश्नपत्रिका उघडण्यासाठी प्रश्नपत्रिकेवर लावलेले सील उघडावे. सील नसलेली किंवा सील उघडलेली प्रश्नपत्रिका स्विकारू नये.
 - पहिल्या पृष्ठावर नमूद केल्याप्रमाणे प्रश्नपत्रिकेची एकूण पृष्ठे तसेच प्रश्नपत्रिकेतील एकूण प्रश्नांची संख्या पडताळून पहावी. पृष्ठे कमी असलेली/कमी प्रश्न असलेली/प्रश्नांचा चुकीचा क्रम असलेली किंवा इतर त्रुटी असलेली सदोष प्रश्नपत्रिका सुरुवातीच्या 5 मिनिटातच पर्यवेक्षकाला परत देऊन दुसरी प्रश्नपत्रिका मागवून घ्यावी. त्यानंतर प्रश्नपत्रिका बदलून मिळणार नाही तसेच वेळही वाढवून मिळणार नाही याची कृपया विद्यार्थ्यांनी नोंद घ्यावी.
 - वरीलप्रमाणे सर्व पडताळून पाहिल्यानंतरच प्रश्नपत्रिकेवर ओ.एम.आर. उत्तरपत्रिकेचा नंबर लिहावा.
- प्रत्येक प्रश्नासाठी (A), (B), (C) आणि (D) अशी चार विकल्प उत्तरे दिली आहेत. त्यातील योग्य उत्तराचा रकाना खाली दर्शविल्याप्रमाणे ठळकपणे काळा/निळ्या करावा.
उदा. : जर (C) हे योग्य उत्तर असेल तर.

<input type="radio"/>	<input type="radio"/>	<input checked="" type="radio"/>	<input type="radio"/>
A	B	C	D
- या प्रश्नपत्रिकेतील प्रश्नांची उत्तरे ओ.एम.आर. उत्तरपत्रिकेतच दर्शवावीत. इतर ठिकाणी लिहिलेली उत्तरे तपासली जाणार नाहीत.
- आत दिलेल्या सूचना काळजीपूर्वक वाचाव्यात.
- प्रश्नपत्रिकेच्या शेवटी जोडलेल्या कोऱ्या पानावरच कच्चे काम करावे.
- जर आपण ओ.एम.आर. वर नमूद केलेल्या ठिकाणा व्यतिरीक्त इतर कोठेही नाव, आसन क्रमांक, फोन नंबर किंवा ओळख पटेल अशी कोणतीही खूण केलेली आढळून आल्यास अथवा असभ्य भाषेचा वापर किंवा इतर गैरमार्गाचा अवलंब केल्यास विद्यार्थ्यांला परीक्षेस अपात्र ठरविण्यात येईल.
- परीक्षा संपल्यानंतर विद्यार्थ्यांने मूळ ओ.एम.आर. उत्तरपत्रिका पर्यवेक्षकांकडे परत करणे आवश्यक आहे. तथापि, प्रश्नपत्रिका व ओ.एम.आर. उत्तरपत्रिकेची द्वितीय प्रत आपल्याबरोबर नेण्यास विद्यार्थ्यांना परवानगी आहे.
- फक्त निळ्या किंवा काळ्या बॉल पेनचाच वापर करावा.
- कॅलक्युलेटर किंवा लॉग टेबल वापरण्यास परवानगी नाही.
- चुकीच्या उत्तरासाठी गुण कपात केली जाणार नाही.

JUN - 37219/II—A

Computer Science and Applications Paper II

Time Allowed : 120 Minutes]

[Maximum Marks : 200

Note : This Paper contains **Hundred (100)** multiple choice questions. Each question carrying **Two (2)** marks. Attempt *All* questions.

1.

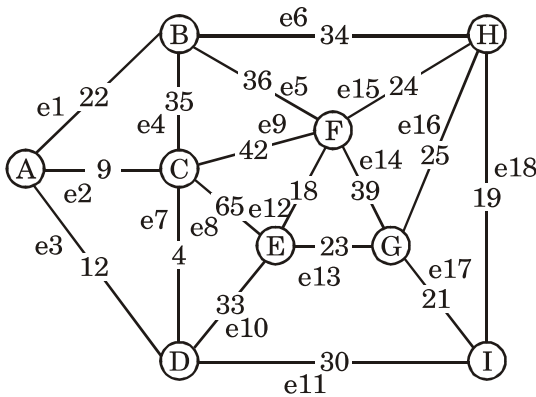

$V = \{A, B, C, D, E, F, G, H, I\}$

$E = \{e_1 = (A, B), e_2 = (A, C), e_3 = (A, D), e_4 = (B, C), e_5 = (B, F), e_6 = (B, H), e_7 = (C, D), e_8 = (C, E), e_9 = (C, F), e_{10} = (D, E), e_{11} = (D, I), e_{12} = (E, F), e_{13} = (E, G), e_{14} = (F, G), e_{15} = (F, H), e_{16} = (G, H), e_{17} = (G, I), e_{18} = (H, I)\}$

$W = \{22, 9, 12, 35, 36, 34, 4, 33, 30, 18, 23, 24, 39, 25, 21, 19\}$

..... is a cut-set in the above graph.

- (A) $\{e_1, e_2, e_4\}$
- (B) $\{e_1, e_2, e_5, e_6\}$
- (C) $\{e_{12}, e_{13}, e_{15}, e_{16}\}$
- (D) $\{e_4, e_7, e_8, e_9\}$

2. Group code set is built by using a generator G of size 5×8 with full rank, then code set weight is

- (A) 5
- (B) 6
- (C) 7
- (D) 8

3. is a received code word knowing that one-bit error occurred while transition of a group code word

generated by $G = \begin{vmatrix} 1 & 0 & 0 & 1 \\ 0 & 1 & 0 & 1 \\ 0 & 0 & 1 & 1 \end{vmatrix}$

- (A) 0011
- (B) 0111
- (C) 1111
- (D) 1100

4. Let $P(x, y)$ be a propositional function, then is a tautology.

- (A) $\exists x P(x, y_0) \rightarrow \forall y P(x_0, y)$, x_0 is a fixed value from domain of x and y_0 is a fixed value from domain of y
- (B) $\exists x P(x, y_0) \rightarrow \exists x \forall y P(x, y)$, y_0 is a fixed value from domain of y
- (C) $\exists x \forall y P(x, y) \rightarrow \forall y \exists x P(x, y)$
- (D) $\exists x \forall y P(x, y) \rightarrow \forall y P(x_0, y)$, x_0 is a fixed value from domain of x

5. Let $A = \{1, 2, 2, 3, 3, 3, 4, 4, 4, 4, 5, 5, 5, 5, 5\}$, $B = \{1, 2, 3, 4, 5\}$, $C = \{1\}$, $D = \{1, \{1\}\}$

- S1 : A and B are equal
 S2 : C and D are equal then is True
- (A) S1 and S2
 - (B) $\sim S1$ and $\sim S2$
 - (C) $\sim S1$ and S2
 - (D) S1 and $\sim S2$

6. Notation :

$$C(n, r) = n! / (r! * (n-r)!)$$

$n!$ is factorial n .

$|A|$ cardinality of set A

\bar{s} is negation of s

$$C(2n, 2) = \dots\dots\dots$$

- (A) $2C(2n, 1)$
- (B) $nC(n, 1) + 2n$
- (C) $2C(n, 2) + n^2$
- (D) $C(n, 2) + 2n^2$

7. Consider the following Linear Programming Problem :

$$\text{Maximize : } Z = 8x_1 + 5x_2$$

$$\text{Subject to } 2x_1 + x_2 \leq 500$$

$$x_1 \leq 150$$

$$x_2 \leq 250, x_1, x_2 \geq 0$$

The value of decision variable after the first iteration will be :

- (A) $x_1 = 0, x_2 = 250$
- (B) $x_1 = 150, x_2 = 0$
- (C) $x_1 = 250, x_2 = 0$
- (D) $x_1 = 150, x_2 = 200$

8. Consider the following Linear Programming Problem :

$$\text{Minimize : } Z = 5x_1 + 10x_2$$

$$\text{Subject to : } x_1 \leq 4$$

$$x_2 \geq 2$$

$$x_1 + x_2 = 5, x_1, x_2 \geq 0$$

The problem is to be solved by simplex method. How many variables are needed to bring it to the standard form ?

- (A) 1 slack, 1 surplus, 2 artificial
- (B) 1 slack, 1 surplus, 1 artificial
- (C) 2 slack, 2 surplus, 2 artificial
- (D) 2 slack, 1 surplus, 2 artificial

9. Consider the following transportation problem :

Destinations

		D ₁	D ₂	D ₃	D ₄	
Sources	S ₁	3	7	6	4	5
	S ₂	2	4	3	2	2
	S ₃	3	8	5	3	3
		3	3	2	2	

The initial solution is obtained by Vogel's method. The initial cost of transportation will be :

- (A) 36
- (B) 32
- (C) 40
- (D) 28

10. Consider the following assignment cost matrix :

		Jobs			
		J ₁	J ₂	J ₃	J ₄
Machines	M ₁	10	9	7	8
	M ₂	5	8	7	7
	M ₃	5	4	6	5
	M ₄	2	3	4	5

The optimal cost of assignment is :

- (A) 24
- (B) 26
- (C) 20
- (D) 18

11. Using De-Morgan's law the simplified form of the expression

$$\overline{(A + \overline{B}) (\overline{A} + B)}$$
 is :

- (A) $A \oplus B$
- (B) $\overline{A}.B + A.\overline{B}$
- (C) $A + B$
- (D) AB

12. What is the single error-correcting code for the information code 10111 for odd parity ?
- (A) 100111110
 (B) 111000001
 (C) 10101011
 (D) 10101100
13. Using 15's complement method of subtraction $69B_H - C14_H$ is :
- (A) $3EB_H$
 (B) $A86_H$
 (C) 579_H
 (D) $- 579_H$
14. Which of the following are the performance parameters of memory ?
- (i) Latency
 (ii) Memory Cycle Time
 (iii) Transfer Rate
- (A) (i) and (ii)
 (B) (ii) and (iii)
 (C) (i) and (iii)
 (D) (i), (ii) and (iii)
15. One of the following is *not* a program control instruction :
- (A) Interrupt-handling instructions
 (B) Subroutine call instructions
 (C) Unconditional branch instructions
 (D) System-control instructions
16. What is the range of instruction addresses to which conditional branches, such as beq and bne can branch in MIPS ?
- (A) $\pm 2^{17}$
 (B) $\pm 2^{16}$
 (C) $\pm 2^{32}$
 (D) $\pm 2^8$
17. SPARC and POWER PC are based on which of the following micro-processor architecture ?
- (A) EPIC
 (B) RISC
 (C) CISC
 (D) None of the above

18. Strobe and Handshaking are mechanisms used to solve problems associated with :

- (A) Synchronous I/O communication
- (B) Asynchronous I/O communication
- (C) Synchronous I/O synchronization
- (D) Asynchronous I/O synchronization

19. The term 'Locality of Reference' is generally associated with :

- (A) Secondary Memory
- (B) Registers
- (C) Main Memory
- (D) Cache Memory

20. Which of the following are the characteristics of multiprocessors ?

- (i) Ability to share main memory and I/O devices
- (ii) Increased reliability because of redundancy in processors
- (iii) Increased throughput because of execution of multiple jobs in parallel
- (iv) Portions of the same job in parallel

- (A) (i) and (ii)
- (B) (i), (ii) and (iii)
- (C) Only (iii)
- (D) (i), (ii), (iii) and (iv)

21. Which of the following is dangling reference ?
- (i) Accessing the storage that is already disposed at users request.
 - (ii) Accessing the storage that is already disposed at the request of processor.
 - (iii) Accessing the variable that is declared but not initialised.
 - (iv) Accessing the reference variable that is declared but not initialised.
- (A) (i) and (ii)
- (B) (ii) and (iii)
- (C) (i), (ii) and (iii)
- (D) (i), (iii) and (iv)
22. Consider the following 'C' fragment of code where a, b, c is given as input then predict the output from the following :
- ```

...
char x, y, z;

printf ("%d", scanf ("%c%c%c", &x, &y, &z));

```
- (A) A syntax error
- (B) A fatal error
- (C) Segmentation violation
- (D) Shows 3 at output
23. Consider the following 'C' program fragment :
- ```

static char data [ ] [10] = {"Java",
"Python", "CSharpe"};

printf ("%d, %d, %d", data, data [0], data [0] [0]);

```
- results in showing memory address (irrespective of context as general) from the following sequences :
- (A) 170, 170, 170
- (B) 170, 172, 174
- (C) 170, 170, 172
- (D) 170, 172, 170

24. In object oriented programming for references and values, which of the following statements are *true* :

- (i) If variables are references, then every object must be created explicitly.
- (ii) If variables are values, then object creation can happen implicitly as result.
- (iii) If variables are references, then every object must be created implicitly
- (iv) If variables are values, then object creation happens explicitly

- (A) (i) and (ii)
- (B) (ii) and (iii)
- (C) (iii) and (iv)
- (D) (i) and (iv)

25. Using a constructor to specify the type conversion is convenient but has implications that can be undesirable in :

- (i) There can be no implicit conversion from a user defined type to basic type.
- (ii) It is not possible to specify a conversion from a new type to an old one without modifying the declaration for the old one.
- (iii) It is not possible to have a constructor with a single argument without also having a conversion.
- (iv) A user defined conversion is implicitly applied only if it's unique.

- (A) (i) and (iv)
- (B) (i), (ii) and (iii)
- (C) (ii), (iii) and (iv)
- (D) (iii) and (iv)

26. Which *one* of the following ensures proper cleanup of objects of the type ?
- (i) Destructor
 - (ii) Delete
 - (iii) Exception Handling
 - (iv) Garbage Collection
- (A) (i) only
- (B) (i) and (ii)
- (C) (iii) only
- (D) (iv) only
27. Microsoft has developed a very general scripting interface, that is implemented uniformly by the operating system called WSH. Here WSH stands for :
- (A) Windows System Handle
 - (B) Windows Sewer Host
 - (C) Windows Scripting Host
 - (D) Windows Scripting Handle
28. Coordinates of a point (x, y) on a circle having centre at (x_c, y_c) and polar coordinates r and θ may be expressed in parametric polar form as :
- (A) $x = x_c + r \cos \theta, y = y_c + r \sin \theta$
 - (B) $x = x_c + r \sin \theta, y = y_c + r \cos \theta$
 - (C) $x = x_c + r \cos \theta, y = y_c + r \cos \theta$
 - (D) $x = x_c + r \sin \theta, y = y_c + r \sin \theta$
29. Binary region codes assigned to line end points according to relative position with respect to the clipping rectangle in the row order are :
- (A) 1001, 1000, 0001, 1010, 0000, 0010, 0101, 0100, 0110
 - (B) 1001, 1000, 1010, 0001, 0000, 0010, 0101, 0100, 0110
 - (C) 1001, 1000, 0001, 1010, 0000, 0101, 0010, 0100, 0110
 - (D) 1001, 1000, 0001, 1010, 0000, 0010, 0100, 0101, 0110

30. Ambient light is light illuminated
..... .

- (A) From a single light source
- (B) From multiple light sources
- (C) By light sources and reflected by various surfaces
- (D) Due to reflection from various surfaces

31. The online redo log contains :

- (i) A record of all committed transactions.
 - (ii) A record of all rolled back transactions.
 - (iii) A list of all the logged in users.
 - (iv) A list of all the associated files.
- (A) (i) and (ii)
 - (B) (i), (ii) and (iii)
 - (C) (i), (ii) and (iv)
 - (D) (ii), (iii) and (iv)

32. Which amongst the following is an example of object based logical model ?

- (A) Network Model
- (B) Hierarchical Model
- (C) Entity Relationship Model
- (D) Relational Model

33. A table has single valued attributes A, B, C, D and E, with the following functional dependencies

$$\{A \rightarrow C, B \rightarrow D, AB \rightarrow E\}$$

In terms of normalization, this table is in :

- (A) 1 NF
- (B) 2 NF
- (C) 3 NF
- (D) BCNF

34. Database contains the relation Employee (id, name, salary), which of the following is an *incorrect* SQL query ?
- (A) Select * from Employee where salary > 10000;
 - (B) Select distinct name from Employee;
 - (C) Select * from Employee order by salary Desc, name Asce;
 - (D) Select * from Employee where name like '%Joshi';
35. Suppose you own a student table, the correct syntax for giving delete privileges to all users of the database with one SQL statement is :
- (A) Grant delete to all on student;
 - (B) Grant delete on student to all;
 - (C) Grant delete to public on student;
 - (D) Grant delete on student to public;
36. Which of the following properties of a transaction are handled by Recovery Manager ?
- (i) Atomicity
 - (ii) Durability
 - (iii) Isolation
 - (iv) Consistency
- (A) (i) and (ii)
 - (B) (i), (ii) and (iii)
 - (C) (i), (ii) and (iv)
 - (D) (i), (ii), (iii) and (iv)
37. A statistical method used to make numerical predictions is
- (A) Regression
 - (B) Support vector machine
 - (C) Hidden Markov model
 - (D) Link analysis
38. Which of the following is the characteristic which is not exhibited by social network ?
- (A) Heavy tailed distribution
 - (B) Densification power law
 - (C) Widening diameter
 - (D) None of the above

39. Acronym for Hadoop YARN is

- (A) Yet Another Repository Navigator
- (B) Yet Another Research Negotiator
- (C) Yet Another Register Negotiator
- (D) Yet Another Resource Negotiator

40. As per the CAP theorem, distributed database can provide to achieve high scalability.

- (A) Availability
- (B) Consistency
- (C) Partition tolerance
- (D) At least two among (A), (B) and (C)

41. Operating system level firewall provides an advantage over a Network level firewall by allowing traffic control/filter according to

- (A) IP Addresses
- (B) Port Numbers
- (C) Application Layer Protocols
- (D) Application Programs

42. Which of the following clouds computing service is most appropriately supported by virtualization technology ?

- (A) Infrastructure as a service (IaaS)
- (B) Platform as a service (PaaS)
- (C) Software as a service (SaaS)
- (D) Communication as a service (CaaS)

43. In Windows operating system, terminal services refer to support for

- (A) Terminating user sessions on a system
- (B) Management of display devices
- (C) Shut down the operating system
- (D) Multiple interactive user sessions on a single system

44. Which command is used to manage hard disk partitions in a Linux system ?

- (A) df
- (B) fdisk
- (C) dd
- (D) iostat

45.

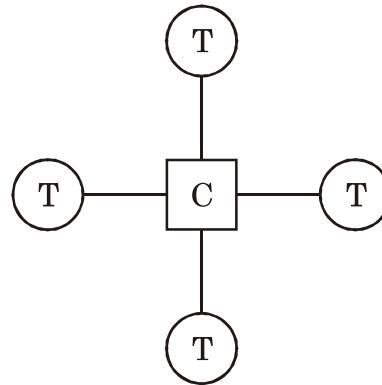

C : Computer System

T : Dumb Terminal

The given diagram most appropriately represents which of the following scenario ?

- (A) Centralized system
- (B) Local-access system
- (C) Distributed system
- (D) Remote-access system

46. Which of the following algorithms may cause starvation ?

- (i) First-come-first-serve
- (ii) Round Robin
- (iii) Priority
- (iv) Shortest process next
- (v) Shortest remaining time first

- (A) (i), (iii) and (v)
- (B) (iii), (iv) and (v)
- (C) (ii), (iv) and (v)
- (D) (ii), (iii) and (iv)

47. Suppose that the number of instructions executed between page fault is directly proportional to the number of page frames allocated to a program. If the available memory is doubled, the mean interval between page faults is also doubled. Further, consider that a normal instruction takes one microsecond, but if a page fault occurs, it takes 2001 microseconds. If a program takes 60 sec. to run, during which time it gets 15,000 page faults, how long would it take to run if twice as much memory were available ?

(A) 60 sec.
 (B) 30 sec.
 (C) 45 sec.
 (D) 10 sec.

48. Three processes A, B and C each executes a loop of 100 iterations. In each iteration of the loop, a process performs a single computation that requires t_c CPU milliseconds and the initiates single I/O operation that requires t_{io} milliseconds. It is assumed that the computer where the processes execute has sufficient number of I/O devices and the OS of the computer assigns different I/O devices to each process. Also, the scheduling overhead of the OS is negligible. The processes have the following characteristics :

Process id	t_c	t_{io}
A	100 ms	500 ms
B	350 ms	500 ms
C	200 ms	500 ms

The processes A, B and C are started at times 0, 5 and 10 milliseconds respectively, in a pure time thrashing system (round robin scheduling) that uses a time slice of 50 milliseconds. The time in milliseconds at which process C would complete its first I/O operation is :

- (A) 700 ms
 (B) 900 ms
 (C) 800 ms
 (D) 1000 ms

49. A 4-way set-associative cache memory unit with a capacity of 16 kB is built using a block size of 8 words. The word length is 32 bits. The size of the physical address space is 4 GB. The number of bits in the TAG field is :
- (A) 5
 (B) 15
 (C) 20
 (D) 25
50. Consider a disk queue with request for input/output to block on cylinders 98, 183, 37, 122, 14, 124, 65 and 67 in that order. Assume that the disk head is initially positioned at cylinder 53 and moving towards cylinder 0. The total number of head movements using Shortest Seek Time First (SSTF) and SCAN algorithms are respectively :
- (A) 236 and 252 cylinders
 (B) 640 and 236 cylinders
 (C) 235 and 640 cylinders
 (D) 236 and 236 cylinders
51. What are the *three* framework activities for the Adaptive Software Development (ASD) process model ?
- (A) Analysis, design, coding
 (B) Feasibility study, functional model iteration, implementation
 (C) Speculation, collaboration, learning
 (D) Requirements gathering, adaptive cycle planning, iterative development
52. In software development process, which of the following is *not* an Agile methodology ?
- (A) XP
 (B) SCRUM
 (C) Waterfall
 (D) Feature Driven Development

53. Which of the following may not be preferred as a tool to specify requirements during requirement gathering stage of a software development project ?

- (A) Use case diagram
- (B) Sequence diagram
- (C) Finite-state machine
- (D) Class diagram

54. Which of the following is *not* a design principle for class based component in modeling component level design ?

- (i) A module should be open for extension but closed for modification.
- (ii) One General purpose interface is always better than many client-specific interfaces.
- (iii) Classes that change together belong together

- (A) (iii) only
- (B) (ii) only
- (C) (i) only
- (D) (i) and (iii) only

55. Which amongst the following are subcharacteristics of Reliability in ISO-9126 quality model ?

- (i) Maturity
- (ii) Recoverability
- (iii) Suitability
- (iv) Fault Tolerance

- (A) (i), (ii) and (iii)
- (B) (i), (ii) and (iv)
- (C) (i), (iii) and (iv)
- (D) (i), (ii), (iii) and (iv)

56. Testing a software for the performance towards extreme or abnormal resource utilization as against normal requirements is known as

- (A) Stress testing
- (B) Recovery testing
- (C) Performance testing
- (D) Security testing

57. Which of the following is a structure which does *not* belong to classes of loops considered for loop testing ?
- (A) Simple loop
- (B) Nested loop
- (C) Concatenated loop
- (D) Structured loop
58. The formula for estimating the development effort and development time of an embedded product is :
- (A) Effort = 2.4 (KLOC)^{1.05} PM,
Tdev = 2.5(Effort)^{0.38} Months
- (B) Effort = 3.0 (KLOC)^{1.12} PM,
Tdev = 2.5(Effort)^{0.35} Months
- (C) Effort = 3.6 (KLOC)^{1.20} PM,
Tdev = 2.5(Effort)^{0.32} Months
- (D) Effort = 2.4 (KLOC)^{1.05} PM,
Tdev = 2.5(Effort)^{0.35} Months
59. The CMM maturity levels measure the :
- (A) Quality of product
- (B) Quantity of modules
- (C) Capabilities of processes
- (D) Process maturity
60. Select the components from the following which contributes in the building of software configuration management (SCM) :
- (i) Software configuration identification (SCI)
- (ii) Change control
- (iii) Configuration status accounting
- (iv) Configuration audit
- (A) (ii) and (iv)
- (B) (i), (ii), (iii) and (iv)
- (C) (i), (ii) and (iii)
- (D) (i), (iii) and (iv)

61. Which of the following applications may use a stack ?

- (A) A parentheses balancing program
- (B) Tracking of local variables at run time
- (C) Compiler syntax analyzer
- (D) All of the mentioned

62. Which of the following concepts make extensive use of arrays ?

- (A) Binary trees
- (B) Scheduling of processes
- (C) Caching
- (D) Spatial locality

63. What is the value of the postfix expression :

6 3 2 4 + - *

- (A) 28
- (B) 24
- (C) 30
- (D) 18

64. A technique for direct search is :

- (A) Linear search
- (B) Binary search
- (C) Hashing
- (D) Tree search

65. Identify the odd one :

- (A) Priority queue
- (B) Circular queue
- (C) Deque
- (D) Tower of Hanoi

66. In-order traversal of a binary search tree gives the output in :

- (A) Non-increasing order
- (B) Unsorted
- (C) Non-decreasing order
- (D) Decreasing order

67. The *correct* ordering of the growth rates 3^n , n^3 , 3^3 , $\log_3 n$ is :

- (A) $\log_3 n$, n^3 , 3^3 , 3^n
- (B) $\log_3 n$, 3^3 , n^3 , 3^n
- (C) 3^3 , $\log_3 n$, 3^n , n^3
- (D) 3^3 , $\log_3 n$, n^3 , 3^n

68. The discovery and finish time for the vertex 5 in depth first traversal for the following graph is :

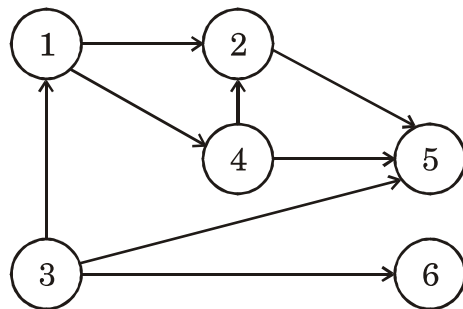

- (A) 3, 5
- (B) 4, 5
- (C) 2, 6
- (D) 1, 3

69. Which amongst the following is *not* an NP problem ?

- (A) Satisfiability problem
- (B) Sorting problem
- (C) Clique decision problem
- (D) Node cover problem

70. Working modulo $q = 11$, how many spurious hits does the Rabin Karp matcher encounter in the text $T = 459263781$ when working for the pattern $\beta = 37$:

- (A) 2
- (B) 3
- (C) 4
- (D) 5

71. Type checking is normally done during

- (A) Lexical Analysis
- (B) Code Generation
- (C) Syntax Analysis
- (D) Syntax Directed Translation

72. Which of the following are types of optimizations that operate on loops and instruction scheduling ?

- (i) Constant Folding
- (ii) Code Hoisting
- (iii) Shrink Wrapping
- (iv) Branch and Basic Block Scheduling

- (A) (i), (ii) and (iv) only
- (B) (i) and (iv) only
- (C) (ii) and (iii) only
- (D) (ii), (iii) and (iv) only

73. Consider an array A of n elements of integer type for assignment statement

$$\text{Value} = A[i]$$

Which of the following is three address code representation for address computation and value assignment above ?

(A) $\text{Temp1} = i * \text{sizeof}(\text{integer})$

$$\text{Temp2} = \&A + \text{Temp1}$$

$$\text{Value} = *(\text{Temp2})$$

(B) $\text{Temp1} = i * \text{sizeof}(\text{integer})$

$$\text{Temp2} = \&A + \text{Temp2}$$

$$*(\text{Temp2}) = \text{value}$$

(C) $\text{Temp1} = \&A * \text{sizeof}(\text{integer})$

$$\text{Temp2} = \text{Temp1} + i$$

$$\text{Value} = *(\text{Temp2})$$

(D) $\text{Temp1} = \&A * i$

$$\text{Temp2} = \text{Temp1} + \text{sizeof}(\text{integer})$$

$$\text{Value} = *(\text{Temp2})$$

74. Which of the following are *correct* statements in context of compiler ?

(i) A grammar is Left Recursive if we can find some non-terminal 'A' which will eventually derive a sentential form with itself as a left symbol.

(ii) Syntax analyzer groups the tokens produced by the scanner into syntactic structures by parsing the expressions and statements.

(iii) A control flow statement is an instruction when executed can cause a change in the subsequent control flow to differ from the natural sequential order in which the instructions are listed.

(A) (i) and (ii) only

(B) (ii) and (iii) only

(C) (i), (ii) and (iii) only

(D) (i) and (iii) only

75. Depending on a programming language which of the following a type checker may prevent ?

- (i) Use of undeclared variables in expressions.
- (ii) Functions that do not return value.
- (iii) Variables are declared before they are used.

- (A) (i) and (ii) only
- (B) (ii) and (iii) only
- (C) (i) and (iii) only
- (D) (i), (ii) and (iii) only

76. LR parsers read their input from to and produce a derivation.

- (A) Left, Right, Rightmost
- (B) Right, Left, Leftmost
- (C) Left, Right, Leftmost
- (D) Right, Left, Rightmost

77. Which among the following is/are correct statement(s) ?

- (i) If there is a TM (or algorithm) which when applied to any problem in the class, always eventually terminates with the correct YES/NO answer, then we call the problem solvable.
- (ii) If there is a TM (or algorithm) which when applied to any problem in the class, always eventually terminates with the correct answer when the answer is YES and with incorrect answer when answer is NO, then we call the problem as unstable.
- (iii) If there is a TM (or algorithm) which when applied to any problem in the class, always, eventually terminates with the correct YES as an answer then we call the problem unsolvable.

- (A) (i) only
- (B) (ii) only
- (C) (iii) only
- (D) (i) and (iii) only

78. Consider the TM described below for computing 2's complement using a transition diagram. In this diagram few of the transition input entries are missing and are denoted by I, II and III.

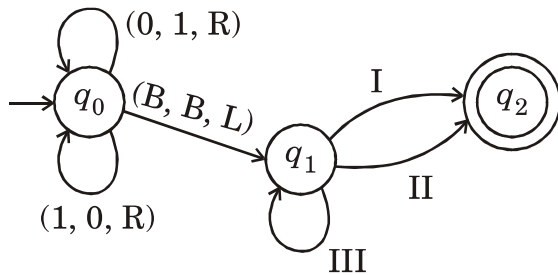

Here L represents left, R represents right and N represents Accept (No movement)

Which of the following is exact replacement for I, II and III above in the order.

- (A) (0, 1, N), (B, 1, N), (1, 0, L)
- (B) (0, 0, N), (B, 1, N), (1, 0, R)
- (C) (1, 0, N), (B, 0, N), (0, 1, R)
- (D) (1, 1, N), (B, 0, N), (0, 1, L)

79. For which context free languages below, we can construct an equivalent PDA with one (1) stack :

- (i) $L = \{a^n b^n c^n / n \geq 1\}$
- (ii) $L = \{a^n b^n / n \geq 1\}$
- (iii) $L = \{a^n b^{2n} / n \geq 1\}$

- (A) (i) and (ii) only
- (B) (ii) and (iii) only
- (C) (i) and (iii) only
- (D) (i), (ii) and (iii) only

80. Which of the following languages are regular :

- (i) $L = \{a^n / n \text{ is a perfect square}\}$
- (ii) $L = \{a^n / n \text{ is even}\}$
- (iii) $L = \{a^n / n \geq 0\}$
- (iv) $L = \{a^n \cup b^n / n \geq 0\}$

- (A) (i) and (iii) only
- (B) (ii) and (iv) only
- (C) (iii) and (iv) only
- (D) (ii) and (iii) only

81. In the infrastructure as a service (IaaS) cloud implementation, “Provisioning” component is responsible for :

- (A) Storing VM images
- (B) Hiring third party IaaS cloud
- (C) VM image repository
- (D) Reservation of VM’s service

82. Which DNS resource record is used to reverse map IP addresses to names ?

- (A) PTR
- (B) MXC
- (C) SRV
- (D) PTR

83. According to the IEEE project 802.11, there are two types of wireless LANs. In an infrastructure-based network, what is a BSA (Base Service Area) ?

- (A) A BSA is a wireless station
- (B) A BSA is a gateway which connects a wireless station to a network
- (C) A BSA is simply a cell
- (D) A BSA is another word for server

84. While designing cloud API using the “Richardson Maturity Model” on level “1”, it uses :

- (A) Individual URI for each resource
- (B) Right HTTP method with status code
- (C) HATEOAS
- (D) All (A), (B) and (C)

85. A telephone line normally has a bandwidth of 3000 Hz assigned for data communications. The signal-to-noise ratio is usually 3162. Then the channel capacity for this channel is :
- (A) 34,860 bps
 (B) 6,262 bps
 (C) 11.62 bps
 (D) 3,854 bps
86. Which of the following CRC generator guarantee the detection of a single bit errors ?
- (A) $X^4 + X^2$
 (B) 1
 (C) $X^3 + X$
 (D) $X^2 + 1$
87. Calculate the HLEN (Header Length) value in IPv4, if the total length is 1200 bytes, 1176 of which is data from the upper layer :
- (A) 4
 (B) 6
 (C) 12
 (D) 16
88. In RSA given two prime numbers $p = 19$ and $q = 23$, find n and ϕ ?
- (A) $n = 437, \phi = 396$
 (B) $n = 381, \phi = 231$
 (C) $n = 38, \phi = 52$
 (D) $n = 19, \phi = 23$

89. Encrypt "INTERNET" using transposition cipher with the following key :

3	5	2	1	4
1	2	3	4	5

- (A) RINTE ZZNET
- (B) ZZNET INTER
- (C) ETRNI NZETZ
- (D) TRNIE TZENZ

90. Which provision can resolve/overcome the shortcomings associated with duplication or failure condition of Stop-and-Wait Automatic Repeat Request protocol especially due to loss of data frames or non-reception of acknowledgement ?

- (A) Provision of sequence number in the header of message
- (B) Provision of checksum computation
- (C) Both (A) and (B)
- (D) None of the above

91. The task environment in case of part-picking robot is :

- (A) Full observable, Deterministic and Episodic
- (B) Partially observable, Stochastic and Sequential
- (C) Fully observable, Deterministic and Sequential
- (D) Partially observable, Stochastic and Episodic

92. Match the knowledge representation schema in Group-1 used to describe situation in Group-2 :

Group-1

- (P) Frames
- (Q) Scripts
- (R) Stereotypes
- (S) Rule models

Group-2

- (i) Common sequence of events
 - (ii) Cluster of characteristics often found together
 - (iii) Common features shared among a set of laws
 - (iv) Collection of attributes that given objects normally possess
- (A) (P) → (ii), (Q) → (i), (R) → (iv), (S) → (iii)
 - (B) (P) → (iv), (Q) → (i), (R) → (iii), (S) → (ii)
 - (C) (P) → (iii), (Q) → (ii), (R) → (i), (S) → (iv)
 - (D) (P) → (iii), (Q) → (iv), (R) → (i), (S) → (ii)

93. Which of the following is *not* a property of planning graph ?

- (A) Literals increase monotonically
- (B) Actions decrease monotonically
- (C) Mutexes decrease monotonically
- (D) Eventually the graph levels off

94. Which visual clues amongst the following are helpful in computer visions ?

- (i) Color
- (ii) Motion
- (iii) Depth
- (iv) Texture
- (v) Height

- (A) (i), (ii), (iii) and (iv)
- (B) (ii), (iii), (iv) and (v)
- (C) (i), (iii), (iv) and (v)
- (D) (ii), (iii), (iv) and (i)

95. Which of the following is *not* true for Internet Book Shopping Agent ?

- (A) Its interface for user requests acts as sensors
- (B) Its ability to follow links acts as actuators
- (C) Its environment as Internet is fully observable and sequential
- (D) Its performance is based on obtaining requested books in minimum cost and time

96. The defining length and order of the schema 1*****1 is :

- (A) $\delta(H) = 13, O(H) = 02$
 (B) $\delta(H) = 10, O(H) = 13$
 (C) $\delta(H) = 12, O(H) = 2$
 (D) $\delta(H) = 12, O(H) = 13$

97. The axiom of excluded middle is represented as :

- (A) $A \cup \bar{A} = X$
 (B) $A \cap \bar{A} = X$
 (C) $\bar{A} \cup \bar{A} = X$
 (D) $\bar{A} \cap \bar{A} = X$

98. The centroid method of defuzzification can be represented by the following algebraic expression :

- (A) $\mu_c(z^*) \geq \mu_c(z) \forall z \in Z$
 (B) $z^* = \frac{\int \mu_c(z).z dz}{\int \mu_c(z) dz}$
 (C) $z^* = \frac{\sum \mu_c(\bar{z}).\bar{z}}{\sum \mu_c(\bar{z})}$
 (D) $z^* = \frac{a+b}{2}$

99. The following table shows attributes of biological and artificial neurons respectively. Match the following according to the functions performed by their counterpart :

List I

- (i) Cell/soma
- (ii) Synapse
- (iii) Dendrites
- (iv) Axon

List II

- (a) Neuron/Node
- (b) Weights
- (c) Net input
- (d) Output
- (A) (i)-(a), (ii)-(b), (iii)-(c), (iv)-(d)
- (B) (i)-(b), (ii)-(c), (iii)-(d), (iv)-(a)
- (C) (i)-(c), (ii)-(d), (iii)-(a), (iv)-(b)
- (D) (i)-(d), (ii)-(a), (iii)-(b), (iv)-(c)

100. In a simple MLP model with 8 neurons in the input layer, 5 neurons in the hidden layer and 1 neuron in the output layer. What is the size of the weight matrices between hidden-output layer and input-hidden layer ?

- (A) $[1 \times 5]$, $[5 \times 8]$
- (B) $[8 \times 5]$, $[1 \times 5]$
- (C) $[8 \times 5]$, $[5 \times 1]$
- (D) $[5 \times 1]$, $[8 \times 5]$

JUN - 37219/II—A

ROUGH WORK

JUN - 37219/II—A

ROUGH WORK