

Test Booklet No.

प्रश्नपत्रिका क्र.

M

Paper-III

ELECTRONIC SCIENCE

Signature and Name of Invigilator

Seat No.

--	--	--	--	--	--	--

(In figures as in Admit Card)

1. (Signature)

(Name)

Seat No.

(In words)

2. (Signature)

(Name)

OMR Sheet No.

--	--	--	--	--	--	--

(To be filled by the Candidate)

DEC - 38313**Time Allowed : 2½ Hours]****[Maximum Marks : 150****Number of Pages in this Booklet : 24****Number of Questions in this Booklet : 75****Instructions for the Candidates**

- Write your Seat No. and OMR Sheet No. in the space provided on the top of this page.
- This paper consists of 75 objective type questions. Each question will carry two marks. All questions of Paper-III will be compulsory, covering entire syllabus (including all electives, without options).
- At the commencement of examination, the question booklet will be given to the student. In the first 5 minutes, you are requested to open the booklet and compulsorily examine it as follows :
 - To have access to the Question Booklet, tear off the paper seal on the edge of this cover page. Do not accept a booklet without sticker-seal or open booklet.
 - Tally the number of pages and number of questions in the booklet with the information printed on the cover page. Faulty booklets due to missing pages/questions or questions repeated or not in serial order or any other discrepancy should not be accepted and correct booklet should be obtained from the invigilator within the period of 5 minutes. Afterwards, neither the Question Booklet will be replaced nor any extra time will be given. The same may please be noted.**
 - After this verification is over, the OMR Sheet Number should be entered on this Test Booklet.
- Each question has four alternative responses marked (A), (B), (C) and (D). You have to darken the circle as indicated below on the correct response against each item.
Example : where (C) is the correct response.

(A)	(B)	(C)	(D)
-----	-----	-----	-----
- Your responses to the items are to be indicated in the **OMR Sheet given inside the Booklet only**. If you mark at any place other than in the circle in the OMR Sheet, it will not be evaluated.
- Read instructions given inside carefully.
- Rough Work is to be done at the end of this booklet.
- If you write your Name, Seat Number, Phone Number or put any mark on any part of the OMR Sheet, except for the space allotted for the relevant entries, which may disclose your identity, or use abusive language or employ any other unfair means, you will render yourself liable to disqualification.
- You have to return original OMR Sheet to the invigilator at the end of the examination compulsorily and must not carry it with you outside the Examination Hall. You are, however, allowed to carry the Test Booklet and duplicate copy of OMR Sheet on conclusion of examination.
- Use only Blue/Black Ball point pen.**
- Use of any calculator or log table, etc., is prohibited.**
- There is no negative marking for incorrect answers.**

विद्यार्थ्यांसाठी महत्वाच्या सूचना

- परिक्षार्थीनी आपला आसन क्रमांक या पृष्ठावरील वरच्या कोपऱ्यात लिहावा. तसेच आपणांस दिलेल्या उत्तरपत्रिकेचा क्रमांक त्याखाली लिहावा.
- सदर प्रश्नपत्रिकेत 75 बहुपर्याय प्रश्न आहेत. प्रत्येक प्रश्नास दोन गुण आहेत. या प्रश्नपत्रिकेतील सर्व प्रश्न सोडविणे अनिवार्य आहे. सदरचे प्रश्न हे या विषयाच्या संपूर्ण अभ्यासक्रमावर आधारित आहेत.
- परीक्षा सुरु झाल्यावर विद्यार्थ्यांला प्रश्नपत्रिका दिली जाईल. सुरुवातीच्या 5 मिनीटांमध्ये आपण सदर प्रश्नपत्रिका उघडून खालील बाबी अवश्य तपासून घ्याव्यात.
 - प्रश्नपत्रिका उघडण्यासाठी प्रश्नपत्रिकेवर लावलेले सील उघडावे. सील नसलेली किंवा सील उघडलेली प्रश्नपत्रिका स्विकारू नये.
 - पहिल्या पृष्ठावर नमूद केल्याप्रमाणे प्रश्नपत्रिकेची एकूण पृष्ठे तसेच प्रश्नपत्रिकेतील एकूण प्रश्नांची संख्या पडताळून घ्यावी. पृष्ठे कमी असलेली/कमी प्रश्न असलेली/प्रश्नांचा चुकीचा क्रम असलेली किंवा इतर त्रुटी असलेली सदोष प्रश्नपत्रिका सुरुवातीच्या 5 मिनिटातच पर्यवेक्षकाला परत देऊन दुसरी प्रश्नपत्रिका मागवून घ्यावी. त्यानंतर प्रश्नपत्रिका बदलून मिळणार नाही तसेच वेळही वाढवून मिळणार नाही याची कृपया विद्यार्थ्यांनी नोंद घ्यावी.
 - वरीलप्रमाणे सर्व पडताळून पहिल्यानंतरच प्रश्नपत्रिकेवर ओ.एम.आर. उत्तरपत्रिकेचा नंबर लिहावा.
- प्रत्येक प्रश्नासाठी (A), (B), (C) आणि (D) अशी चार विकल्प उत्तरे दिली आहेत. त्यातील योग्य उत्तराचा रकाना खाली दर्शविल्याप्रमाणे ठळकपणे काळा/निळा करावा.
उदा. : जर (C) हे योग्य उत्तर असेल तर.

(A)	(B)	(C)	(D)
-----	-----	-----	-----
- या प्रश्नपत्रिकेतील प्रश्नांची उत्तरे ओ.एम.आर. उत्तरपत्रिकेतच दर्शवावीत. इतर ठिकाणी लिहिलेली उत्तरे तपासली जाणार नाहीत.
- आत दिलेल्या सूचना काळजीपूर्वक वाचाव्यात.
- प्रश्नपत्रिकेच्या शेवटी जोडलेल्या कोऱ्या पानावरच कच्चे काम करावे.
- जर आपण ओ.एम.आर. वर नमूद केलेल्या ठिकाणा व्यतिरीक्त इतर कोठेही नाव, आसन क्रमांक, फोन नंबर किंवा ओळख पटेल अशी कोणतीही खूण केलेली आढळून आल्यास अथवा असभ्य भाषेचा वापर किंवा इतर गैरमार्गाचा अवलंब केल्यास विद्यार्थ्यांला परीक्षेस अपात्र ठरविण्यात येईल.
- परीक्षा संपल्यानंतर विद्यार्थ्यांनी मूळ ओ.एम.आर. उत्तरपत्रिका पर्यवेक्षकांकडे परत करणे आवश्यक आहे. तथापी, प्रश्नपत्रिका व ओ.एम.आर. उत्तरपत्रिकेची द्वितीय प्रत आपल्याबरोबर नेण्यास विद्यार्थ्यांना परवानगी आहे.
- फक्त निळा किंवा काळा बॉल पेनचाच वापर करावा.**
- कॅलक्युलेटर किंवा लॉग टेबल वापरण्यास परवानगी नाही.**
- चुकीच्या उत्तरासाठी गुण कपात केली जाणार नाही.**

DEC - 38313/III

Eelectronic Science
Paper III

Time Allowed : 2½ Hours]

[Maximum Marks : 150

Note : This Paper contains **Seventy Five (75)** multiple choice questions, each question carrying **Two (2)** marks. Attempt *All* questions.

-
- | | |
|---|--|
| <p>1. The pinch off voltage V_p for a FET is the drain to source voltage at which :</p> <p>(A) a considerable drain current starts flowing</p> <p>(B) drain current does not flow</p> <p>(C) channel gets constricted</p> <p>(D) avalanche break-down occurs</p> <p>2. A varactor diode is usually :</p> <p>(A) Forward biased</p> <p>(B) Reverse biased</p> <p>(C) Does not require bias</p> <p>(D) Both forward and reverse biased</p> | <p>3. A transistor in CE-configuration has :</p> <p>(A) high I/P and low O/P resistance</p> <p>(B) low I/P and high O/P resistance</p> <p>(C) low I/P and low O/P resistance</p> <p>(D) high I/P and high O/P resistance</p> <p>4. For an intrinsic semiconductor, Fermi level lies :</p> <p>(A) at the mid gap</p> <p>(B) near the conduction band</p> <p>(C) near the valence band</p> <p>(D) within conduction band</p> |
|---|--|
-

5. Growth of single crystal Si is normally favoured along :
- (A) $\langle 1\ 1\ 1 \rangle$ direction
 (B) $\langle 0\ 0\ 1 \rangle$ direction
 (C) $\langle 1\ 0\ 1 \rangle$ direction
 (D) $\langle 1\ 1\ 0 \rangle$ direction
6. Match the pairs and select the correct answer from the codes given below :

List I

- (a) Epitaxy
 (b) Electronic charge
 (c) V-groove
 (d) MOSFET

List II

- (i) 1.6×10^{-19} coulombs
 (ii) Growth of single crystal Si
 (iii) Voltage controlled device
 (iv) Isolation method

Codes :

- (a) (b) (c) (d)
 (A) (ii) (i) (iv) (iii)
 (B) (i) (iii) (ii) (iv)
 (C) (iii) (iv) (i) (ii)
 (D) (iv) (ii) (iii) (i)

7. If the base current of transistor is 100 mA and the current gain is 30, the emitter current is
- (A) 3.33 A
 (B) 3 A
 (C) 3.1 A
 (D) 30 A
8. The maximum power that can be transferred to the load resistor R_L from the voltage source in the figure shown below is :

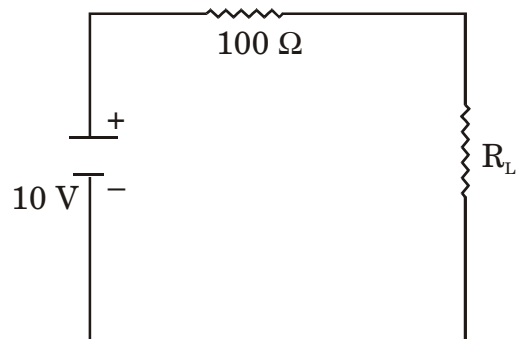

- (A) 1 W
 (B) 10 W
 (C) 0.25 W
 (D) 0.5 W

9. In the circuit shown in figure the switch S has been opened for a long time. It is closed at $t = 0$. The values of $V_L(0+)$ and $I_L(0+)$ are

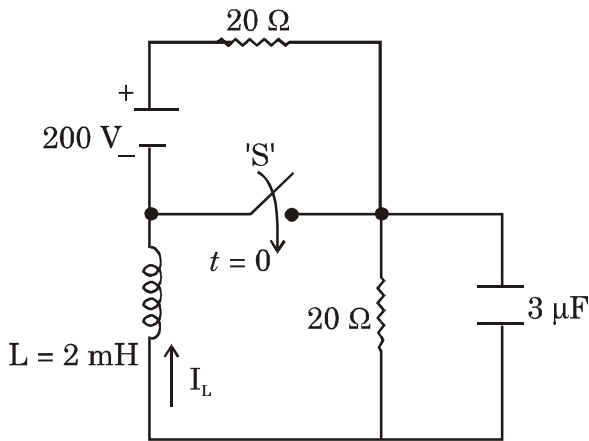

- (A) 200 V, -5 A
- (B) 0 V, 5 A
- (C) 100 V, 5 A
- (D) 100 V, -5 A

For answering Q. No. 10 and Q. No. 11 refer to the circuit shown in the figure is initially under a steady state condition :

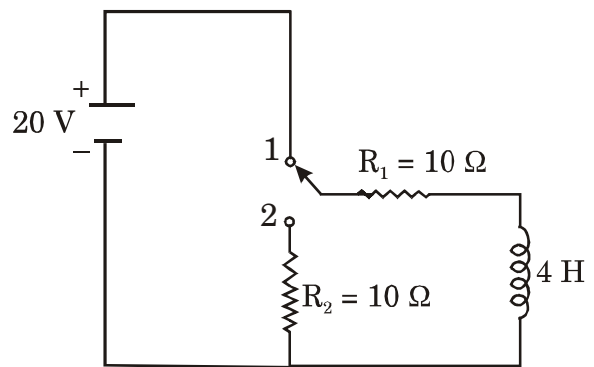

The switch is moved from position 1 to position 2 at $t = 0$.

10. The current through inductor immediately after switching is
- (A) 2 A
 - (B) $\frac{1}{2}$ A
 - (C) 1 A
 - (D) 5 A

11. The expression for current $i(t)$ is

- (A) e^{-5t}
- (B) $2.e^{-5t}$
- (C) $\frac{2}{5}.e^{-5t}$
- (D) $5.e^{-2t}$

12. For the network shown in the following figure, the transfer

function $\frac{V_2(s)}{V_1(s)}$ is :

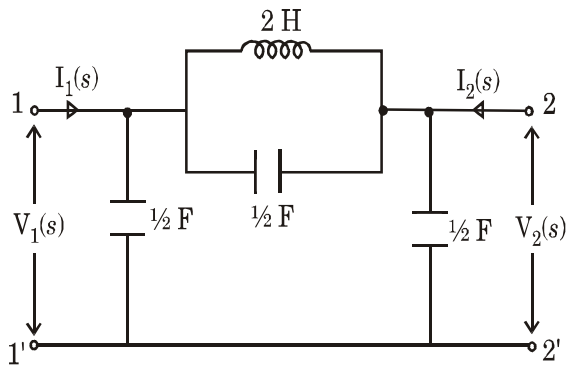

- (A) $\frac{s^2 - 1}{2s^2 + 2}$
- (B) $\frac{s^2 - 1}{2s^2 - 1}$
- (C) $\frac{s^2 + 1}{2s^2 + 1}$
- (D) $\frac{s^2 + 1}{2s^2 - 1}$

13. The transmission parameters for the following circuit are :

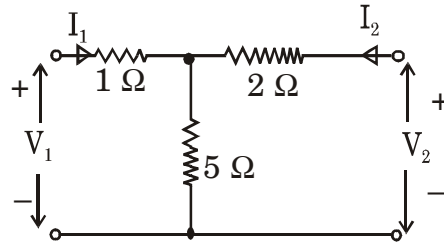

- (A) $A = \frac{7}{5}, B = \frac{1}{5}, C = \frac{-119}{50},$

$D =$

- (B) $A = \frac{1}{5}, B = \frac{7}{5}, C = \frac{6}{5},$

$D = \frac{-119}{50}$

- (C) $A = , B = \frac{-119}{50}, C = ,$

$D = \frac{7}{5}$

- (D) $A = \frac{-119}{50}, B = , C = \frac{7}{5},$

$D = \frac{1}{5}$

14. Match the following and select the correct answer from the codes given below :

List I

(a) $\frac{10}{s(s+10)}$

(b) $\frac{10}{s^2+100}$

(c) $\frac{(s+10)}{(s+10)^2+100}$

(d) 10

List II

(1) $10 \delta(t)$

(2) $[e^{-10t} \cdot \cos 10 t] \cdot u(t)$

(3) $[\sin 10 t] \cdot u(t)$

(4) $[1 - e^{-10t}] \cdot u(t)$

Codes :

(a) (b) (c) (d)

(A) (3) (4) (1) (2)

(B) (3) (4) (2) (1)

(C) (4) (3) (2) (1)

(D) (4) (3) (1) (2)

• Choose the *correct* options in case of Q. No. 15 to Q. No. 18 after studying the following circuit :

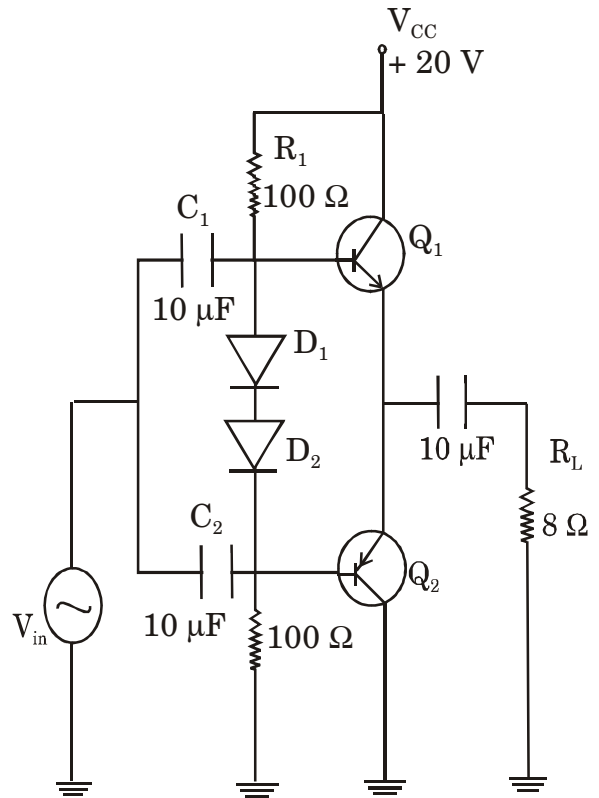

For Q_1 and Q_2 $\beta_{ac} = 50$ and ac emitter resistance $r'_e = 6 \Omega$.

15. The maximum peak output voltage is :

(A) 5 V

(B) 10 V

(C) 15 V

(D) 20 V

16. The maximum peak output current is :

- (A) 1 A
- (B) 0.75 A
- (C) 2.25 A
- (D) 1.25 A

17. The ac output power is :

- (A) 12.5 W
- (B) 6.25 W
- (C) 7.96 W
- (D) 25 W

18. The input resistance is :

- (A) 10 Ω
- (B) 500 Ω
- (C) 700 Ω
- (D) 1 k Ω

19. CMRR is the ratio of :

- (A)
- (B) Ad.Acm
- (C) $\frac{A_{cm}}{A_d}$
- (D) $\frac{1}{A_d.A_{cm}}$

20. The following circuit stands for :

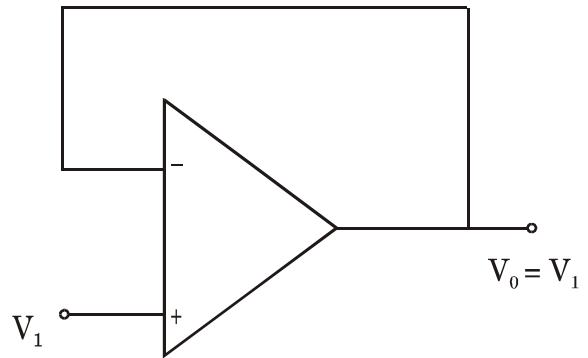

- (A) Buffer amplifier
- (B) Inverting amplifier
- (C) Non-inverting amplifier
- (D) Cascade amplifier

21. The volt-ampere equivalent of temperature is :

- (A) $\frac{kT}{e}$
- (B) $\frac{e}{kT}$
- (C) $\frac{T}{k.e.}$
- (D) $\frac{k}{T.e.}$

22. Using four cascaded counters with a total of 16 bits, how many states must be deleted to achieve a modulus of 50,000 ?
- (A) 50,000
(B) 65,536
(C) 25,536
(D) 15,536
23. If an analog signal is to be converted into digital with an 8 bit resolution, how many comparators are used in a parallel encoded ADC ?
- (A) 127
(B) 128
(C) 255
(D) 256
24. Which of the following describes the basic operation of a single slope A/D converter ?
- (A) The VCO quits changing frequency when the input voltage stabilizes. The frequency of the VCO, which is proportional to the analog voltage, is measured and is displayed on the digital display as a voltage reading
- (B) A ramp generator is used to enable a counter through a comparator. When the ramp voltage equals the input voltage, the counter is latched and then reset. The counter reading is proportional to the input voltage since the ramp is changing at a constant V/second rate
- (C) A ramp voltage and analog input voltage are applied to a comparator. As the input voltage causes the integrating capacitor to charge, it will at some point equals the ramp voltage. The ramp voltage is measured and displayed on the digital panel meter
- (D) The input is compared with the number of levels of a resistive ladder and the output is encoded and displayed on a digital panel meter

25. Match List I with List II and select the correct answer using the codes given below the lists :

List I

- (a) ECL
- (b) CMOS
- (c) TTL
- (d) RTL

List II

- (i) Low power dissipation
- (ii) Current mode logic
- (iii) Slow switching speed
- (iv) Totem-pole arrangement

Codes :

- (a) (b) (c) (d)
- (A) (iii) (iv) (i) (ii)
- (B) (iv) (iii) (ii) (i)
- (C) (ii) (i) (iv) (iii)
- (D) (i) (ii) (iii) (iv)

- Read the following and answer the questions from 26 to 28 based on the same :

A low power Schottky TTL is a modification of standard TTL in which larger resistances and Schottky diodes are used. The larger resistances decrease the power dissipation, and the Schottky diodes increases the speed. In case of such a low power Schottky TTL NOR gate, the specifications are as follows :

Parameter	Value
V_{CC}	5 V
I_{CH}	1.6 mA (Feeding 4 gates)
I_{CL}	2.8 mA (Feeding 4 gates)

V_{OH} (min)	2.7 V
V_{OL} (min)	0.4 V
V_{IH} (max)	2.0 V
V_{IL} (max)	0.8 V
I_{OH} (max)	4.0 mA (out)
I_{OL} (max)	8.0 mA (in)
I_{IH} (max)	0.02 mA (in)
I_{IL} (max)	0.4 mA (in)
t_{PLH}	10 ns
t_{PHL}	10 ns

26. The power dissipation of the above referred low power Schottky TTL NOR gate is :

- (A) 1.75 mW
- (B) 3.75 mW
- (C) 4.75 mW
- (D) 2.75 mW

27. One of the following statements hold good in case of the above referred low power Schottky TTL NOR gate. Indicate the same :

- (A) Both fan-out and fan-in are same which is equal to 10
- (B) Fan-out and fan-in are different and their values are 10 and 20 respectively
- (C) Both fan-out and fan-in are same which is equal to 20
- (D) Fan-out and fan-in are different and their values are 20 and 10 respectively

28. The propagation delay of the above referred low power Schottky TTL NOR gate is :

- (A) 10 ns
- (B) 20 ns
- (C) 30 ns
- (D) 40 ns

29. Match List I (State diagram) with List II (name of the flip-flop) and select the *correct* answers from the codes given below the lists :

List I

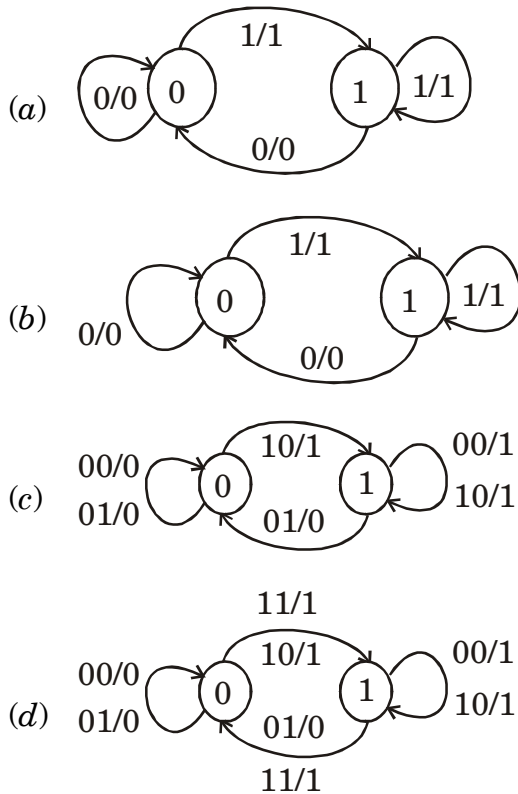

List II

- (i) S-R- flip-flop
- (ii) D-flip-flop
- (iii) J-K flip-flop
- (iv) T-flip-flop

Codes :

- | | | | | |
|-----|-------|-------|-------|-------|
| | (a) | (b) | (c) | (d) |
| (A) | (i) | (ii) | (iii) | (iv) |
| (B) | (i) | (iii) | (iv) | (ii) |
| (C) | (ii) | (iv) | (i) | (iii) |
| (D) | (iii) | (i) | (ii) | (iv) |

Read the following program written in 8085 assembly language and answer the question Nos. 30 to 32 :

```

2000    LXI SP, # 2100 H
2003    LXI B, # 0000 H
2006    PUSH B
2007    POP PSW
2008    LXI H, # 200B H
200B    CALL DELAY
200E    OUT 01 H
2010    HLT
    
```

DELAY : 2064 PUSH H

2065 PUSH B

2066 LXI B, # 80FF H

LOOP : 2069 DCXB

206A MOV A, B

206B ORA C

206C JNZ LOOP

206F POP B

2070 RET

30. The memory location where the program return after the subroutine is
- (A) $(200B)_H$
 (B) $(2064)_H$
 (C) $(2069)_H$
 (D) $(2070)_H$
31. The status of the flags and the contents of the accumulator after the execution of the POP instruction located at $(2007)_H$ is
- (A) Sign flag set, $(ACC) = (00)_H$
 (B) Sign flag reset, $(ACC) = (FF)_H$
 (C) All flag reset, $(ACC) = (00)_H$
 (D) All flag set, $(ACC) = (FF)_H$
32. The contents of the stack pointer register and the program counter after the execution of CALL instruction are as follows :
- (A) $SP = (2069)_H$ $PC = (200E)_H$
 (B) $SP = (20FE)_H$ $PC = (2064)_H$
 (C) $SP = (2010)_H$ $PC = (2000)_H$
 (D) $SP = (200B)_H$ $PC = (200B)_H$
33. Arrange the following in descending order the type of memory depending on speed of operations :
- (a) static RAM
 (b) static ROM
 (c) dynamic RAM
 (d) flash RAM
- (A) (a) (b) (c) (d)
 (B) (a) (c) (d) (a)
 (C) (d) (a) (c) (b)
 (D) (d) (c) (a) (b)
34. In interfacing the memory externally to an 8085 microprocessor the following signals are required :
- (A) Address and data bus
 (B) Control bus RD, WR, chip select signal (\overline{OE})
 (C) Only address Bus and RD, WR, \overline{OE} signal
 (D) Both (A) and (B)
35. I/O in 8085 based system can be accessed by :
- (A) I/O instructions
 (B) Memory instructions
 (C) I/O and memory instructions
 (D) I/O or memory instructions depending on which I/O is connected as I/O map or memory map

36. Match the following peripherals of 8085 bus system with the function they can perform and select the correct answer from the codes given below :

I/O device/chip

- (1) 8155
 (2) 8255
 (3) 8279
 (4) 8253

Function

- (a) I/O + RAM
 (b) Keyboard and Display
 (c) Timer and Counter
 (d) I/O port only
 (e) Serial Rs 232

Codes :

- (1) (2) (3) (4)
 (A) (a) (d) (b) (c)
 (B) (d) (a) (c) (b)
 (C) (c) (d) (a) (b)
 (D) (b) (c) (e) (d)

37. In C programming a comment can be initiated by the :

- (A) / and *
 (B) / & //
 (C) * and **
 (D) * & /

38. The C programming language provides some of the following basic data types. Match with suitable examples and select the correct answer from the codes given below :

Type

- (1) long int
 (2) long double
 (3) unsigned long int
 (4) _Bool

Constant examples

- (i) 0, 1
 (ii) 12.34, 3.1×10^{-5}
 (iii) 12.341, 3.1×10^{-51}
 (iv) 12411, 0xffee UL
 (v) 12 L, -97, 0XFFEO

Codes :

- (1) (2) (3) (4)
 (A) (v) (iii) (i) (v)
 (B) (ii) (iv) (ii) (v)
 (C) (iii) (ii) (i) (iv)
 (D) (v) (iii) (iv) (i)

39. Translation of assembly code into machine code in an embedded system is performed by :

- (A) Assembler
 (B) Compiler
 (C) Linker
 (D) Locator

40. A list in which each entry contains a pointer to the preceding entry in the list as well as pointer to the next entry in the list is known as :
- (A) Tree
(B) Double linked list
(C) Circular list
(D) Singly linked list
41. **Assertion (A) :** The programmer doesn't have to write the printf and scanf routines because.
- Reason (R) :** Both printf and scanf are part of the standard C library.
- (A) Both (A) and (R) are true and (R) is the correct explanation of (A)
(B) Both (A) and (R) are true but (R) is not the correct explanation of (A)
(C) The (A) is true but (R) is false
(D) The (A) is false but (R) is true
42. The data transmitted by a device connected to serial port is properly displayed on a hyperterminal if :
- (A) the bit length is 8 bits only
(B) the baud rate of transmission and reception are matched
(C) the correct decryption algorithm is used
(D) proper graphics adapter is used
43. Given a uniform ring of charge with opposite charge located at the center, the net force on the central charge is :
- (A) Outward
(B) Inward
(C) Zero
(D) Out of plane

44. A $\frac{\lambda}{4}$ transformer in a transmission line helps in :

- (A) reducing voltage
- (B) increasing voltage
- (C) reflecting the voltage
- (D) matching the impedance

45. The reflection coefficient for a system is $|\rho|e^{j\theta_v}$. For a particular load arrangement, first minimum from the load is at . The angle θ_v is :

- (A)
- (B) $-\pi$
- (C) 0
- (D) π

Figure shows construction of a hybrid ring with four ports for question nos. 46 and 47.

46. For an input at port P1, the output appears at :

- (A) P2
- (B) P2, P3
- (C) P3, P4
- (D) P2, P4

47. For an input at port P2, the output appears at :

- (A) P3, P4
- (B) P1, P4
- (C) P4 only
- (D) P1, P3

48. In a metallic cylindrical wave guide the boundary conditions require that component :

- (A) $E_\phi = 0$
- (B) $E_r = 0$
- (C) $E_z = 0$
- (D) $E_\phi = E_z = 0$

49. For a plane polarized wave moving in z -direction with E_x and H_y as its components, ratio E_x/H_y is :

- (A) $3 \times 10^8 \Omega$
- (B) 75Ω
- (C) 377Ω
- (D) 50Ω

The modulation is given by

$$V(t) = 100 \cos[2\pi f_c t + 4\sin 2000\pi t]$$

and $f_c = 10 \text{ MHz}$.

Answer question Nos. 50 and 51 based on this information.

50. The average transmitted power is

- (A) 5 kW
- (B) 3 kW
- (C) 2 kW
- (D) 4 kW

51. The maximum frequency deviation is

- (A) 3 kHz
- (B) 2 kHz
- (C) 4 kHz
- (D) 1 kHz

52. The random variable X has the probability function :

$$f_x(x) = k, \text{ for } x = 0$$

$$= 2k, \text{ for } x = 1$$

$$= 3k, \text{ for } x = 2$$

$$= 0, \text{ otherwise}$$

Then k is

- (A) $\frac{1}{2}$
- (B) $\frac{1}{6}$
- (C) $\frac{1}{3}$
- (D) $\frac{5}{6}$

53. An RC filter based pre-emphasis de-emphasis is employed in FM system. The de-emphasis first order RC filter has $R = 2 \text{ k}\Omega$, $C = 0.05 \mu\text{F}$. The gain in dB for the FM broadcasting system which has the base bandwidth of 15 kHz is :

- (A) 5.4 dB
- (B) 1.5 dB
- (C) 18.8 dB
- (D) 7.3 dB

54. Match the following lists. List I is name of a shift keying technique and List II represents wave forms. Choose the correct answer from the codes given below :

List I

- (a) BFSK
- (b) ASK
- (c) BPSK
- (d) QPSK

List II

- (i)
- (ii)
- (iii)
- (iv)

Codes :

- | | | | | |
|-----|------|-------|------|-------|
| | (a) | (b) | (c) | (d) |
| (A) | (ii) | (i) | (iv) | (iii) |
| (B) | (iv) | (iii) | (i) | (ii) |
| (C) | (ii) | (iii) | (iv) | (i) |
| (D) | (iv) | (iii) | (ii) | (i) |

55. Six message signals each of bandwidth 5 kHz are time division multiplexed and transmitted. The signaling rate the minimum channel bandwidth for the PAM/TDM channel will be :

- (A) 60 K bits/s and 30 kHz
- (B) 30 K bits/s and 60 kHz
- (C) 10 K bits/s and 30 kHz
- (D) 480 K bits/s and 240 kHz

56. **Assertion (A)** : PCM is a “digital” modulation system because.

Reason (R) : The PCM system consists of an encoder and a decoder.

- (A) Both (A) and (R) are true and (R) is the correct explanation of (A)
- (B) Both (A) and (R) are true and (R) is not the correct explanation of (A)
- (C) The (A) is true but (R) is false
- (D) Both (A) and (R) are false

57. A communication system consisting of six messages with probabilities $\frac{1}{4}$, $\frac{1}{4}$, $\frac{1}{8}$, $\frac{1}{8}$, $\frac{1}{8}$ and $\frac{1}{8}$ respectively, the entropy of the system would be :
- (A) 16 bits/message
 (B) 2.5 bits/message
 (C) 3 bits/message
 (D) 12 bits/message
58. The IGBT has the following drawback :
- (A) Low voltage and current rating
 (B) High switching losses
 (C) Long turn on and turn off times
 (D) High conduction losses
59. A three phase half wave rectifier has a supply of 150 V/phase. What is the required diode PRV rating ? Assuming the load current is level at 25 A, and each diode has a voltage drop of 0.7 V.
- (A) 152 V
 (B) 286 V
 (C) 386 V
 (D) 552 V

60. Match the items from List I with List II and select the correct answer from the codes given below :

List I

- (a) SCR
 (b) UJT
 (c) IGBT
 (d) Diode

List II

- (i) Rectifier
 (ii) Half-wave controlled rectifier
 (iii) Trigger device
 (iv) Low voltage drop power device

Codes :

- (a) (b) (c) (d)
 (A) (iii) (iv) (i) (ii)
 (B) (ii) (iii) (iv) (i)
 (C) (i) (ii) (iii) (iv)
 (D) (iv) (iii) (ii) (i)

61. **Assertion (A) :** IR lasers are used for long haul transmission with operating frequency 193 THz.

Reason (R) : The line width of semiconductor lasers are of the order of fraction of nm.

- (A) Both (A) and (R) are true and (R) is the correct explanation of (A)
 (B) Both (A) and (R) are true but (R) is not the correct explanation of (A)
 (C) (A) is true and (R) is false
 (D) (A) is false but (R) is true

62. Match the items from List I with List II and select the correct answer from the codes given below :

List I

- (a) Silicon
(b) GaAs
(c) Silica
(d) Water

List II

- (i) Impurity
(ii) Detection
(iii) Photo-emission
(iv) Optical fiber

Codes :

- (a) (b) (c) (d)
(A) (ii) (iii) (iv) (i)
(B) (iv) (iii) (i) (ii)
(C) (ii) (iv) (iii) (i)
(D) (iii) (i) (ii) (iv)

63. Match the items from List I with List II and select the correct answer from the codes given below :

List I

- (a) PN Diode
(b) PIN Diode
(c) Avalanche Diode
(d) LDR

List II

- (i) Broadband
(ii) High quantum efficiency
(iii) Low cost
(iv) High speed

Codes :

- (a) (b) (c) (d)
(A) (ii) (i) (iv) (iii)
(B) (iii) (ii) (iv) (i)
(C) (iv) (iii) (i) (ii)
(D) (i) (iv) (iii) (ii)

64. Silicon P-i-N detector are *not* suitable for the following wavelength :

- (A) 850 nm
(B) 1060 nm
(C) 630 nm
(D) 1300 nm

65. The following are the losses found in fiber joints :

- (a) Lateral misalignment
(b) Angular misalignment
(c) Longitudinal misalignment
(d) Reflection loss

Arrange these losses in increasing order :

- (A) (a) (b) (c) (d)
(B) (c) (b) (a) (d)
(C) (d) (c) (b) (a)
(D) (c) (a) (d) (b)

66. Match the following and select the correct answer from the codes given below :

List I

- (i) Resistive
(ii) Capacitive
(iii) Photovoltaic
(iv) Electromagnetic

List II

- (a) Limit switches
(b) Temperature, pressure
(c) Velocity acceleration
(d) Sound pressure, moisture
(e) pH and conductivity

Codes :

- (i) (ii) (iii) (iv)
(A) (c) (a) (e) (b)
(B) (b) (d) (a) (c)
(C) (a) (c) (b) (d)
(D) (d) (a) (b) (c)

67. The factors that affect the measurement are :
- (A) The measuring instrument and environmental conditions
- (B) The measuring instrument and the person using the instrument
- (C) The person using instrument and environmental condition
- (D) The measuring instrument, the person using instrument and environmental conditions
68. Measuring in process control is basically used to monitor the :
- (A) Process input parameters
- (B) Process input and output parameters
- (C) Process input, output and surrounding environmental parameters
- (D) Process output and environmental parameters
69. The following precautions should be observed when using ammeter for measurement :
- (i) Never connect an ammeter across a source of emf
- (ii) Using multirange meter use lowest current first
- (iii) Using multirange meter use highest range first
- (iv) Observe the correct polarity if analog type ammeter is used
- (A) (i) only
- (B) (i) and (iii)
- (C) (i), (iii) and (iv)
- (D) (ii) only
70. A certain crystal has a coupling coefficient of 0.32. How much electrical energy must be applied to produce an output of 1 oz. in of mechanical energy.
(1 oz. in = 7.06×10^{-3} J)
- (A) 22.19 mJ
- (B) 2.219 mJ
- (C) 221.9 mJ
- (D) 0.2219 mJ
71. The post-deflection acceleration in a CRT is used in high frequency oscilloscopes mainly to :
- (A) increase the deflection sensitivity
- (B) improve the beam focussing
- (C) improve the deflection linearity
- (D) improve the spot brightness

72. A 10-bit successive approximation type A/D converter working in the range of 0-10 V takes 50 μs to analog signal of 10 volts. Then the time it takes to convert 5 V signal would be :

- (A) 25 μs
- (B) Slightly more than 25 μs
- (C) Slightly less than 25 μs
- (D) 50 μs

73. Temperature was measured in eight locations in a room and the values obtained were 21.2°, 25.0°, 18.5°, 22.1°, 19.7°, 27.1°, 19.0° and 20.0°C then the arithmetic mean and standard deviation will be :

- (A) 21.6°C and 3.04°C
- (B) 21.7°C and 3.03°C
- (C) 21.8°C and 3.02°C
- (D) 21.5°C and 3.04°C

74. If the Nyquist plot cuts the negative real axis at a distance of, then the gain margin of the system is -2.5 dB.

- (A) 0.2
- (B) 0.4
- (C) 0.6
- (D) 1.333

75. The approximate Bode magnitude plot of a minimum phase system is shown in the following figure. The transfer function of the system is

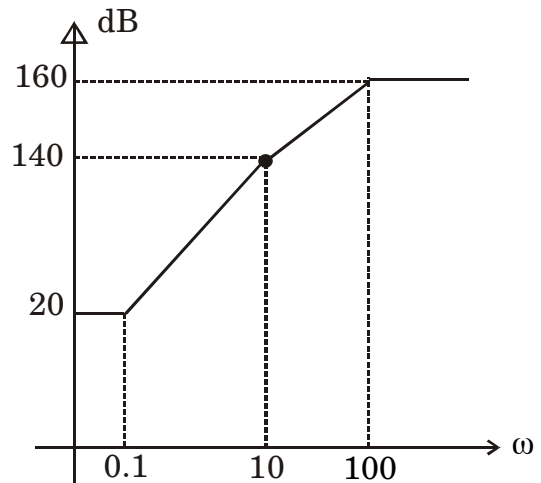

- (A) $10^8 \cdot \frac{(s + 0.1)^3}{(s + 10)^2 (s + 100)}$
- (B) $10^7 \cdot \frac{(s + 0.1)^3}{(s + 10) (s + 100)}$
- (C) $10^8 \cdot \frac{(s + 0.1)^2}{(s + 10)^2 (s + 100)}$
- (D) $10^9 \cdot \frac{(s + 0.1)^3}{(s + 10) (s + 100)^2}$

DEC - 38313/III

ROUGH WORK

DEC - 38313/III

ROUGH WORK