

7. Arts DBMS is designed to maintain general database and provide all facilities required for wide range of business application software. Arts DBMS has optimal scheduler to perform transactions for better performance. Which of the following serializable schedules would Arts DBMS scheduler prefer ?

(A)

Transaction 1	Transaction 2
Read X	Read X
.....	
Write X	
	Write X
Read Y	Read Z
Write Y	Write Z

(B)

Transaction 1	Transaction 2
Read X	
.....	
Write X	
	Read X
	Write X
Read Y	
Write Y	
	Read Z
	Write Z

(C)

Transaction 1	Transaction 2
Read X	
Read Y	
Write X	
Write Y	
	Read X
	Read Z
	Write X
	Write Z

(D)

Transaction 1	Transaction 2
Read X	
.....	
Write X	
	Read X
	Write X
Read Y	Read Z
Write Y	Write Z

8. In order to improve the performance of Arts DBMS mentioned in question number 7, the Scheduler further started handling parallel events in multiuser mode. At some instant of time the system entered a deadlock state with the following transaction scenario :

Transaction	Data items locked by transaction	Data items transaction is waiting for
T1	X2	X1, X3
T2	X3, X10	X7, X8
T3	X8	X4, X5
T4	X7	X1
T5	X1, X5	X3
T6	X4, X9	X6
T7	X6	X5

The DBMS started analysing the state and decided to overcome the situation by aborting minimum number of transactions. The system started testing serially and found that by aborting some transactions it could remove the deadlock whereas some transactions were found strong such that by aborting those it could not remove the deadlock state.

In the situation above, termination of which transaction *does not* affect the deadlock state ?

- (A) T6 (B) T5
(C) T2 (D) T3

9. In continuation with the scenario described in question number 7 and 8, consider time stamping mechanism instead of locks for tackling concurrency related problems. In that case Arts DBMS maintains a record of different transaction times for each data item in the system. For example, $t\text{-In}(x)$ denotes the time of insertion of the data item x into the system, $t\text{-Del}(x)$ denotes the time of deletion of the data item x from the system. Similarly, $t\text{-R}(x)$ denotes the time when the x was last read and $t\text{-W}(x)$ denotes the time of last update of the item x in the system. The scheduler receives a request from any process regarding any item x , in the form given below :

(\langle transaction-type \rangle , \langle request-time \rangle , \langle item \rangle).

If the request is valid then it is granted and the corresponding changes are made in the database. The assumptions are as follows :

- (i) Insertion is valid iff the item does not exist in the database.
- (ii) Read is valid iff the item does exist in the database and the last update is older than the current transaction.
- (iii) Deletion and update (write) are valid iff the item exists and is not being used by any other process.

Which concurrency control technique does Arts DBMS follow now ?

- (A) Total Timestamp ordering
- (B) Partial Timestamp ordering
- (C) Multiversion Timestamp ordering
- (D) Read-Write Timestamp ordering

10. Arts DBMS is used to implement automation of Shivam Engineering. Shivam Engineering is a private organisation manufacturing compressors. It has five branches located at places 200 to 1000 Kms from the central head office. Instead of having a centralised database, the MIS manager of Shivam Engineering opts for a distributed database system. All sites will have Arts DBMS in order to avoid any problem of mismatched database capabilities.

Which type of distributed database is implemented at Shivam Engineering ?

- (A) Heterogeneous DDBS (B) Homogeneous DDBS
(C) Multi-database System (D) Federal database System
11. DBA of Shivam Engineering allocated data to six different sites applying a technique of data distribution. After a test period, DBA checked the performance of the system with respect to standard parameters. He found that the locality of reference, reliability and availability, performance are satisfactory, whereas communication and storage costs are high.

Which data distribution technique might the DBA have implemented ?

- (A) Centralised (B) Partitioned
(C) Replicated (D) Fragmented
12. As Shivam Engineering decided to implement a distributed database system, Arts DBMS needs to upgrade its components to maintain atomicity and durability of distributed transactions as well as consistency of data. Arts DBMS recovery mechanism is upgraded to recover the data even in case of failure of any one site including the coordinating site, without blocking any site.

Which recovery mechanism was applied in Arts DBMS ?

- (A) Two-phase commit (B) Three-phase commit
(C) Roll-backward recovery (D) Roll-forward recovery

For the answers to the next three questions read the paragraph given below :

In My Computer if you want to select a colour, you have a choice of Colour1 or Colour2 or Colour3. Call this set Palette. Further, a colour pixel is either set to invisible mode or it is visible. I wish to increase the choice for the colour to be selected in My Computer by adding the following logic : Add 50% white to get light shades and add 50% black to get dark shades. Call it New Palette.

13. In order to facilitate New Palette, what is minimum number of bits needed per pixel ?

- (A) 10
- (B) 7
- (C) 5
- (D) 6

14. Given : Let Display be the function that takes three parameters (position, colour and visibility), and paints the pixel. Here position indicates coordinates of the point to be painted, colour specifies the colour from Palette for painting the pixel, which is invisible if visibility set to 0 and is visible otherwise.

What is the purpose of the body of the While loop in the following algorithm ?

$x = 0; y = 0$

while not keypressed() do

 Display ((x, y), Colour2, x)

$x = x + 1$

 Display ((x, y), Colour1, x)

 delay for 50 milliseconds

enddo

- (A) Draw a two colour line (consecutive points are of different colours) that starts at the origin
- (B) A point started at the origin progressing in the positive direction of the X-axis, leaving the trail in the other colour.
- (C) A point moving horizontally
- (D) (B) or (C) above

15. Let Colour1, Colour2 and Colour3 be Red, Green and Blue, respectively. In your picture, you want to show a butterfly with red and green spots on its violet wings. Which of the statements below is *true* ?
- (A) It is not possible to show this picture
 - (B) It is possible to paint the wings of the butterfly in violet
 - (C) Red and green on violet can be shown by changing the texture of the wings from violet to red and blue
 - (D) Both (B) and (C)
16. The entities given in the set {PDF, 3-D Studio Max, graphic design, cartoon animation, calligraphy} are closely associated with :
- (A) Graphics editing
 - (B) Vector graphics
 - (C) Raster graphics
 - (D) Both (B) and (C)
17. Assuming that $a \neq b \neq c$, to what transformation does this 4×4 matrix correspond to ?

$$\begin{matrix} a & 0 & 0 & 0 \\ 0 & b & 0 & 0 \\ 0 & 0 & c & 0 \\ 0 & 0 & 0 & 1 \end{matrix}$$

- (A) shear
- (B) non-uniform scaling
- (C) rotation
- (D) uniform scaling

18. A 2-dimensional rotation of a point about the origin by 180 degrees in anticlockwise direction, followed by reflection about the x axis is equivalent to reflection about which line ?

(A) $y = -x$

(B) $y = x$

(C) $x = 0$

(D) $y = 0$

19. Predict the output of the following pseudo-code for $F(5)$:

```
function F(var  $n$  : integer)
```

```
begin
```

```
    if  $n \neq 0$ 
```

```
        then
```

```
            print  $n$ 
```

```
            F( $n - 1$ )
```

```
            print  $n$ 
```

```
end
```

(A) 5544332211

(B) 554433221100

(C) 54321

(D) 5432112345

20. Which of the following arrays represents the given binary tree ?

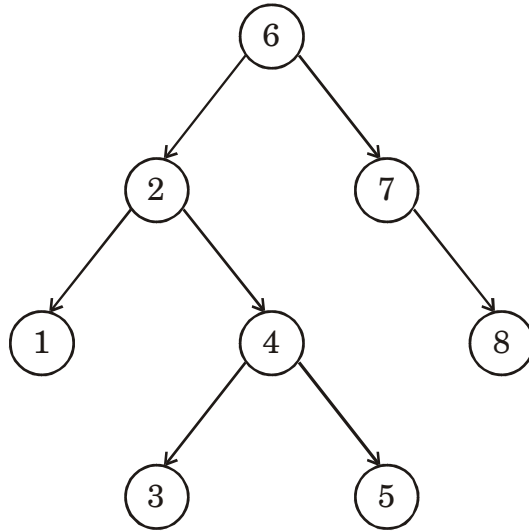

6	2	7	1	4		8			3	5		
	1	2	3	4	5	6	7	8	9	10	11	12

(A)

6	2	7	1	4	8	3	5				
---	---	---	---	---	---	---	---	--	--	--	--

(B)

(C)

6	2	7	1	4		8		3	5		
---	---	---	---	---	--	---	--	---	---	--	--

(D)

1	2	3	4	5	6	7	8				
---	---	---	---	---	---	---	---	--	--	--	--

21. Predict the output of the following pseudo-code for F(5) :

```
function F(var  $n$  : integer)
```

```
  var
```

```
     $n$  : integer
```

```
     $i$  : integer
```

```
     $x$  : integer
```

```
  begin
```

```
     $i \leftarrow 0$ 
```

```
    while  $i < n$  do
```

```
      begin
```

```
        print  $i$ 
```

```
         $i \leftarrow i + 1$ 
```

```
      end
```

```
  end
```

- (A) 0 1 2 3 4
- (B) Output cannot be predicted due to redeclaration of variable ' n '
- (C) Error in pseudo-code due to redeclaration of variable ' n '
- (D) Error in pseudo-code due to unused variable ' x '

22. Predict the output of the following flow-chart :

(Note : ++ in post-increment operator in $i++$ and $j++$)

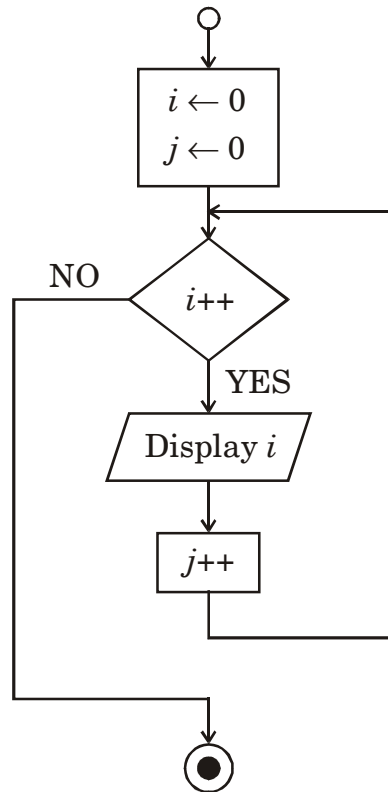

- (A) 0 1 2 3 4 5
- (B) 1 2 3 4 5 6
- (C) No output
- (D) Error

23. Conceptually which of the following language paradigm is most powerful in terms of its ability to solve given problems ?

- (i) Procedure oriented
- (ii) Object oriented
- (iii) Functional
- (iv) Logical

- (A) (i) and (ii)
- (B) (ii)
- (C) (iii)
- (D) All are equal

24. Consider the following scenario :

- Class 'A' contains a variable 'x' and a method 'fa'.
- Class 'B' is derived from Class 'A'.
- Class 'B' contains a method 'fb'.

What should be the visibility of 'x' in 'A' to satisfy the following requirements :

- 'x' should be accessible to 'fa' and 'fb'.
- 'x' should not be accessible to users of 'A' or 'B' objects.

- (A) Private
- (B) Protected
- (C) Public
- (D) The requirements cannot be satisfied

25. Let $g(x) = x^3 + x + 1$. Find the cyclic redundancy check (CRC) codeword-corresponding to the information sequence 1001 :

- (A) 0111
- (B) 110
- (C) 1011
- (D) 011

Consider the following information to answer questions **26** and **27** :

Consider an ARQ (Automatic Repeat Request) protocol that uses only negative acknowledgments (NAKs), but no positive acknowledgements (ACKs). Under these conditions :

26. The condition for timeouts needed is that :

- (A) No Timer required
- (B) NAK TIMER is required at receiver side
- (C) NAK TIMER is required at sender side
- (D) Both (B) and (C)

27. The ACK based ARQ is preferred to the NAK based protocol due to :
- (A) Easy management
 - (B) Increased complexity at sender and receiver due to NAKs
 - (C) ACKs are faster than NAKs
 - (D) NAKs consume more bandwidth
28. Suppose you are designing a sliding window protocol for a 1-Mbps point-to-point link to Mars, which has a one-way latency of 1.25 seconds. Assuming that each frame carries 1 kb of data, the minimum number of bits you need for the sequence number is :
- (A) 9 bits
 - (B) 11 bits
 - (C) 10 bits
 - (D) 12 bits
29. A communications link provides 1 Mbps for communications between the earth and the moon. The link is used to send color images from the moon. Each image consists of $10,000 \times 10,000$ pixels, and 16-bits are used for each of the three-color components of each pixel. How many images per second can be transmitted over the link ?
- (A) 2.1×10^{-4}
 - (B) 2.1×10^4
 - (C) 2.1×10^{-5}
 - (D) 2.2×10^6

32. Assume that we have already applied InW 'myword', and InB 'mybyte' into an empty UD, where myword = '00001110 00101010', and mybyte = '00001111'. What is the value of X ? Assume that X value is 'Limit' when UD is empty.
- (A) Limit + 1 (B) Limit - 1
 (C) Limit + 3 (D) Limit - 2
33. The content of UD remains as in Q. No. 32. Now the following operations are carried out : InB X, InW Y, InB Z, OutB, OutB, OutB, OutW. The contents of UD is now :
- (A) 14, 42 (B) 42, 19, 34
 (C) 5, 503, 42 (D) 14, 42, 19
34. The contents of UD are contained in the range R_1 and R_2 (both excluded and $R_1 < R_2$). What is the maximum number of InB operations that can be carried out ?
- (A) 0 (B) R_2
 (C) $2 \cdot R_2 - 2 \cdot R_1 + 2$ (D) $2 \cdot R_1 - 2 \cdot R_2 + 1$
35. Let P be the set problems solvable in deterministic polynomial time, NP is the set of problems solvable in non-deterministic polynomial time, NPC is the set of NP complete problems.
- Given $X = P \cap NP$, $Y = NP - P$, $Z = P \cap NPC$, which of the following is true ?
- (A) $X = NP$, $Y \neq \phi$, $Z = \phi$ (B) $X = P$, $Y \supseteq NPC$, $Z \neq \phi$
 (C) $X = P$, $Y \supseteq NPC$, $Z = \phi$ (D) $X = NP$, $Y \supseteq NPC$, $Z \neq \phi$

40. By abstraction in object-oriented modeling we mean picking :
- (A) only attributes appropriate to model an object
 - (B) only operations appropriate to model an object
 - (C) operations and attributes appropriate to model an object
 - (D) the appropriate abstract data type
41. Inheritance in object-oriented modeling can be used to :
- (A) generalize classes
 - (B) specialize classes
 - (C) generalize and specialize classes
 - (D) create new classes
42. An object is selected for modeling a system provided :
- (A) its attributes are invariant during operation of the system
 - (B) its attributes change during operation of the system
 - (C) it has numerous attributes
 - (D) it has no attribute relevant to the system
43. In the software functionality is verified against the SRS.
- (A) Stress testing
 - (B) Integration testing
 - (C) White box testing
 - (D) Black box testing
44. Suppose you have to gather requirements from users for a rather complicated but small scale system in one sitting. In this scenario, which of the following is a better choice over the others ?
- (A) Waterfall model
 - (B) Iterative model
 - (C) Prototype model
 - (D) Spiral model

45. Which among the following is *not* a class-oriented software metric ?

- (A) Depth of inheritance tree
- (B) Weighted methods per class
- (C) Coupling between classes
- (D) Class content complexity

46. In an application written in Java, it was found that a particular computationally-intensive module, that contains 1% of the total code of the entire software, takes 40% of the execution time. Call the module HeavyModule.

Given : To code such an application in Java, it takes 100 man days. Programming in Assembly Language takes 10 times more man days than in Java. However, the programs coded in Assembly Language runs 10 times faster than the programs coded in Java. Converting a Java program into Assembly Level language takes 5 times more man days than that of developing it directly in Assembly.

What is the cost of converting HeavyModule into Assembly language, compared to the cost of deciding at design time to write 99% of the code in Java and 1% in Assembly ?

- (A) A design-time decision and developing the code in the respective languages saves around 5% of the time and brings 40% speed up in execution time
- (B) Design time decision and developing the code in the respective languages costs around 4% higher in terms of the time and brought 40% speed up in the execution time
- (C) Late decision to convert HeavyModule into Assembly saves almost 4% of the man days and reduces the execution time by 36%
- (D) Late decision to convert HeavyModule into Assembly increases the man days by almost 4% but reduces the execution time by 36%

47. With software emerging as a service on the internet, a useful set of software metrics for web applications have emerged. Which of the following metrics measures navigation flow ?
- (A) Connectivity density (B) Page complexity
(C) Selection complexity (D) Layout complexity
48. Two programmers, each with productivity 100 LOC per month, were employed to complete a project of size 48 KLOC within a year's time. In the 10th month it was realized that the project was lagging behind the completion schedule. Two extremely good quality programmers (having productivity 200 LOC/month) were additionally employed for the next two months. Interpersonal interactions hampered productivity. Assuming that a line of communication between any two persons causes 5% reduction in the team's productivity, what would be the status of the project at the end of the 12th month ?
- (A) Completed before deadline
(B) 4/5 of the work is completed
(C) 3/4 of the work is completed
(D) 2/3 of the work is completed

Consider the following passage to answer questions from Q. Nos. 49 to 54 :

Virtual Memory is a technique that allows the execution of processes that may not be completely in the memory. In this system of over-allocation, while a user process is executing, a page fault occurs. The operating system determines where the desired page is in the memory, but then finds that there are no free frames. In that case, it finds a victim page to be swapped out, thereby making a frame free for the desired page to be swapped in. For this, there are many different page-replacement algorithms. FIFO Page Replacement, LRU Page Replacement, Optimal Page Replacements, etc. are some of the known algorithms. The basic objective of page-replacement algorithms is to minimize the number of page faults. We can do this minimization by distributing heavily-used pages evenly over all of memory, rather than having them compete for a small number of page frames. We can also associate with each page frame a counter of the number of pages that are associated with that frame. Then, to replace a page, we search for the page frame with the smallest counter. We

Suppose that for a particular process under execution, the following page reference string is encountered :

1, 2, 3, 4, 5, 3, 4, 1, 6, 7, 8, 7, 8, 9, 7, 8, 9, 5, 4, 5, 4, 2.

51. How many page faults occur for “FIFO Page Replacement Algorithm” for the above given page reference string for four frames ?
- (A) 11 page faults (B) 20 page faults
(C) 16 page faults (D) 13 page faults
52. How many page faults occur for “LRU Page Replacement Algorithm” for the above given page reference string for four frames ?
- (A) 11 page faults (B) 10 page faults
(C) 13 page faults (D) 18 page faults
53. How many page faults occur for “Optimal Page Replacement Algorithm” for the above given page reference string for four frames ?
- (A) 11 page faults (B) 13 page faults
(C) 15 page faults (D) 17 page faults
54. How many page faults occur for “Best CBPR Algorithm” for the above given page reference string for four frames ?
- (A) 09 page faults (B) 10 page faults
(C) 14 page faults (D) 12 page faults

Data to answer the questions numbered 55 to 58 below :

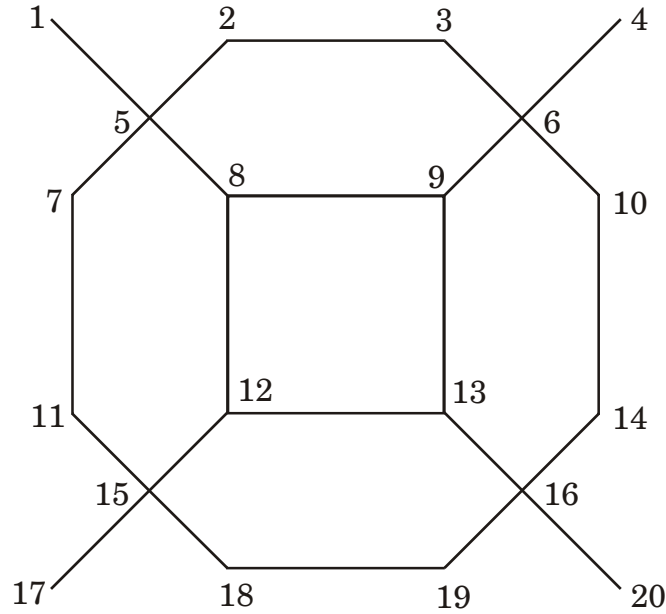

Rangoli graph

55. Definitions :

At any instant, dynamicDegree of a node is the number of untraversed edges that meet at the node.

Heuristic H1 : Among the adjacent nodes, select the one that has the least non-zero dynamicDegree count. (If there is more than one such node, select any *one* of them.)

Heuristic H2 : Visit the selected node by traversing the corresponding edge.

Procedure TraverseRangoli : Begin at Node 1. Keep following H1 and H2 alternately.

Which of the following is *true* about TraverseRangoli ?

- (A) Does not terminate
- (B) Traversal is effectively a DFS
- (C) Equivalent to the A* algorithm
- (D) Generates an AND-OR graph

58. An arbitration mechanism is added to modify NewH1, therefore :

Modified Heuristic NewerH1 : Among the adjacent nodes, select the one with the greatest degree. Choose the one that has largest label, i.e., Node number, in case there is more than one such node.

Modified Heuristic NewerH2 : Visit the selected node by traversing the corresponding edge provided the edge has not been traversed before. Correspondingly,

Procedure NewerTraverseRangoli (i) : Begin at Node i . Keep the following NewerH1 and NewerH2 alternately.

Which of the following is *true* about NewerTraverseRangoli ?

- (A) NewerH1 uniquely defines a path to visit all four Nodes of degree 4.
- (B) NewerH2 ensures that the path does not involve any cycle.
- (C) Both (A) and (B)
- (D) Neither (A) nor (B)

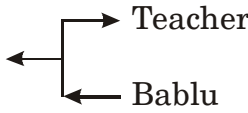
59. Teacher \Leftrightarrow ATRANS \leftarrow Chocolate \leftarrow  most appropriately represents :

- (A) Bablu gives Chocolate to Teacher
- (B) Teacher takes Chocolate from Bablu
- (C) Both (A) and (B)
- (D) Neither (A) nor (B)

60. Teacher \Leftrightarrow MBUILD \leftarrow Teacher \Leftrightarrow LOVE \leftarrow Bablu is to represent :

- (A) Teacher understands that she loves Bablu
- (B) Teacher understands that Bablu loves her
- (C) Bablu understands that Teacher loves him
- (D) Bablu understands that he loves Teacher

61. The number of states in the minimal state DFA, where the transition diagram is given as follows, are :

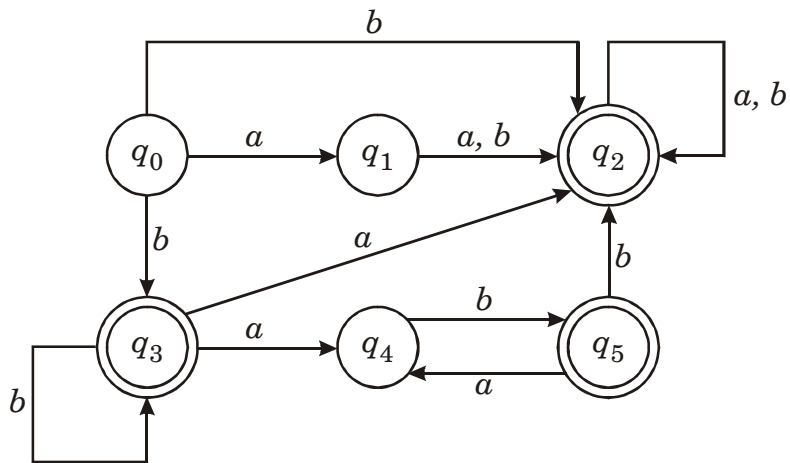

- (A) 2
- (B) 3
- (C) 4
- (D) 5

62. Match the following :

- | | |
|--------------------------|--|
| (a) Matching Parenthesis | (1) $P : \{S \rightarrow aSb \mid bSa \mid \epsilon\}$ |
| (b) Palindromes | (2) $P : \{S \rightarrow SS \mid aSa \mid bSb \mid \epsilon\}$ |
| (c) Expressions | (3) $P : \{S \rightarrow aSa \mid bSb \mid a \mid b \mid \epsilon\}$ |
| (c) Matching count | (4) $P : \{S \rightarrow SaS \mid SbS \mid c \mid d\}$ |
- (A) (a)—(2), (b)—(1), (c)—(4), (d)—(3)
- (B) (a)—(2), (b)—(3), (c)—(4), (d)—(1)
- (C) (a)—(1), (b)—(2), (c)—(3), (d)—(4)
- (D) (a)—(1), (b)—(3), (c)—(4), (d)—(2)

63. Which of the following pairs have different expressive power ?

P	Deterministic Finite Automata (DFA) and Non-Deterministic Finite Automata (NFA)
Q	Deterministic Pushdown Automata (DPDA) and Non-Deterministic Pushdown Automata (NPDA)
R	Single Tape Turing Machine and Multi-tape Turing Machine
S	Turing Machine and Two Stack Pushdown Automata
T	Single Stack Pushdown Automata and Two Stack Pushdown Automata

- | | |
|-------------------|------------------|
| (A) Q, R, S and T | (B) Q and S |
| (C) Q and T | (D) All of these |

64. A channel has two input and output symbols {0, 1} and a common probability p of incorrect decoding of an input at the output. The channel is :
- (A) binary symmetric channel (B) discrete memoryless channel
(C) burst channel (D) binary asymmetric channel
65. When an error-detecting code with even parity check is used, 101101 will be transmitted as :
- (A) 101100 (B) 101101
(C) 1011011 (D) 1011010
66. Elimination of which redundancy will lead to loss of quantitative information ?
- (A) Coding redundancy
(B) Interpixel redundancy
(C) Psychovisual redundancy
(D) Coding and interpixel redundancy

Information for Question Nos. **67** and **68** :

Consider the following problem :

Hardbrick Company has two kilns. Kiln-I can produce 3000 grey bricks, 2000 red bricks and 300 glazed bricks daily. For Kiln-II the corresponding figures are 2000, 5000 and 1500. Daily operating costs of Kiln-I and Kiln-II are Rs. 4,000 and Rs. 6,000 respectively. Find the number of days of operation for each kiln so that the operation cost incurred in meeting an order of 9000 grey, 17000 red and 4500 glazed bricks is minimized.

Let x_1 and x_2 be the number of operation days for Kiln-I and Kiln-II respectively.

67. The mathematical form of the above problem is :

(A) Minimize : $4000x_1 + 6000x_2$

Subject to $3000x_1 + 2000x_2 \geq 9000$

$$2000x_1 + 5000x_2 \geq 17000$$

$$300x_1 + 1500x_2 \geq 4500$$

$$x_1, x_2 \geq 0$$

(B) Minimize : $4000x_1 + 6000x_2$

Subject to $3000x_1 + 2000x_2 = 9000$

$$2000x_1 + 5000x_2 = 17000$$

$$300x_1 + 1500x_2 = 4500$$

$$x_1, x_2 \geq 0$$

(C) Maximize : $-4000x_1 - 6000x_2$

Subject to $3000x_1 + 2000x_2 \leq 9000$

$$2000x_1 + 5000x_2 \leq 17000$$

$$300x_1 + 1500x_2 \leq 4500$$

$$x_1, x_2 \geq 0$$

(D) None of the above

68. The dual of the above problem is :

(A) Maximize $Z' = 9000y_1 + 17000y_2 + 4500y_3$

Subject to $3000y_1 + 2000y_2 + 300y_3 \geq 4000$

$2000y_1 + 5000y_2 + 1500y_3 \geq 6000$

$y_1, y_2 \geq 0$

(B) Maximize $Z' = 9000y_1 + 17000y_2 + 4500y_3$

Subject to $3000y_1 + 2000y_2 + 300y_3 \leq 4000$

$2000y_1 + 5000y_2 + 1500y_3 \leq 6000$

$y_1, y_2 \geq 0$

(C) Maximize $Z' = 9000y_1 + 17000y_2 + 4500y_3$

Subject to $3000y_1 + 2000y_2 + 300y_3 = 4000$

$2000y_1 + 5000y_2 + 1500y_3 = 6000$

$y_1, y_2 \geq 0$

(D) Maximize $Z' = -9000y_1 - 17000y_2 - 4500y_3$

Subject to $3000y_1 + 2000y_2 + 300y_3 \geq 4000$

$2000y_1 + 5000y_2 + 1500y_3 \geq 6000$

$y_1, y_2 \geq 0$

69. Consider the following assignment problem. The cost matrix of assignments of 4 jobs (J_1, J_2, J_3, J_4) on 4 machines (M_1, M_2, M_3, M_4) is given by :

	J_1	J_2	J_3	J_4
M_1	10	9	8	7
M_2	3	4	5	6
M_3	2	1	1	2
M_4	4	3	5	6

An assignment of jobs on machines is as follows :

$$M_1 \rightarrow J_3 \quad M_2 \rightarrow J_1 \quad M_3 \rightarrow J_4 \quad M_4 \rightarrow J_2$$

Which of the following is *true* about this assignments ?

- (A) Given assignment is not feasible.
 - (B) Given assignment is feasible, but not optimal.
 - (C) Given assignment is feasible and optimal.
 - (D) The problem is degenerate and cannot be solved by Hugarian method.
70. Commonly used neuron activation functions are :
- (I) Linear function
 - (II) Threshold binary function
 - (III) Sigmoid function
 - (IV) Hyperbolic Tangent function
 - (V) Gaussian function

Which functions have the good properties of being differentiable, monotonic and bounded ?

- (A) (I), (II) and (III)
- (B) (III) and (IV)
- (C) (III), (IV) and (V)
- (D) (I), (II), (IV) and (V)

71. There are five jobs {1, 2, 3, 4, 5} and the criteria to be applied are interestingness of the job involved and the demands on time required to carry out the job. The two fuzzy sets are given as follows :

$$\text{InterestingJob} = \left\{ \frac{.7}{1} + \frac{.3}{2} + \frac{.5}{3} + \frac{.3}{4} + \frac{.4}{5} \right\}$$

$$\text{DemandingJob} = \left\{ \frac{.4}{1} + \frac{.8}{2} + \frac{.4}{3} + \frac{.3}{4} + \frac{.7}{5} \right\}$$

The fuzzy set for the job that is interesting but not demanding is given by :

- (A) $\left\{ \frac{.7}{1} + \frac{.8}{2} + \frac{.5}{3} + \frac{.3}{4} + \frac{.7}{5} \right\}$ (B) $\left\{ \frac{.4}{1} + \frac{.3}{2} + \frac{.4}{3} + \frac{.3}{4} + \frac{.4}{5} \right\}$
 (C) $\left\{ \frac{.6}{1} + \frac{.2}{2} + \frac{.5}{3} + \frac{.3}{4} + \frac{.3}{5} \right\}$ (D) $\left\{ \frac{.3}{1} + \frac{.7}{2} + \frac{.5}{3} + \frac{.7}{4} + \frac{.6}{5} \right\}$

72. Crisp sets follow certain good properties some of which are given below :

- (I) DeMorgan's law
- (II) Law of excluded middle
- (III) Involution
- (IV) Idempotency
- (V) Law of contradiction
- (VI) Commutativity

Fuzzy sets follow all these properties, *except* :

- (A) (I), (II) and (III) (B) (II) and (V)
 (C) (III) and (IV) (D) (II) and (III)

73. The 'touch' command on UNIX system :

- (A) Creates a new file without opening it
- (B) Creates a new file after opening it
- (C) Creates a new file by opening and closing it immediately
- (D) Creates a new file by renaming an old file

74. The following is the source code corresponding to a 'bash' shell script 's1.sh' in UNIX system;

```
echo "$0 $# $* $1 $2"
```

What will be the output if 's1.sh' is executed from the console as follows :

```
$sh s1.sh sh s1.sh
```

- (A) s1.sh 2 sh s1.sh
 - (B) s1.sh 2 sh s1.sh sh
 - (C) s1.sh 2 sh s1.sh sh s1.sh
 - (D) Displays an error message
75. Which of the following statements is most appropriate ?
- (A) MFC programming can be done through C language.
 - (B) MFC programming can be done through C++ language.
 - (C) MFC programming can be done through C and C++ languages.
 - (D) MFC programming can be done through any language.

FEB - 37313/III

ROUGH WORK