

Test Booklet Code & Serial No.

प्रश्नपत्रिका कोड व क्रमांक
Paper-III

B

PHYSICAL SCIENCE

Signature and Name of Invigilator

Seat No.

--	--	--	--	--	--

1. (Signature)

(In figures as in Admit Card)

(Name)

Seat No.

(In words)

2. (Signature)

(Name)

OMR Sheet No.

--	--	--	--	--	--

(To be filled by the Candidate)

JAN - 32318

Time Allowed : 2½ Hours]

[Maximum Marks : 150

Number of Pages in this Booklet : 28

Number of Questions in this Booklet : 75

Instructions for the Candidates

- Write your Seat No. and OMR Sheet No. in the space provided on the top of this page.
- This paper consists of **75** objective type questions. Each question will carry *two* marks. *All* questions of Paper-III will be compulsory, covering entire syllabus (including all electives, without options).
- At the commencement of examination, the question booklet will be given to the student. In the first 5 minutes, you are requested to open the booklet and compulsorily examine it as follows :
 - To have access to the Question Booklet, tear off the paper seal on the edge of this cover page. Do not accept a booklet without sticker-seal or open booklet.
 - Tally the number of pages and number of questions in the booklet with the information printed on the cover page. Faulty booklets due to missing pages/questions or questions repeated or not in serial order or any other discrepancy should not be accepted and correct booklet should be obtained from the invigilator within the period of 5 minutes. Afterwards, neither the Question Booklet will be replaced nor any extra time will be given. The same may please be noted.**
 - After this verification is over, the OMR Sheet Number should be entered on this Test Booklet.
- Each question has four alternative responses marked (A), (B), (C) and (D). You have to darken the circle as indicated below on the correct response against each item.
Example : where (C) is the correct response.

(A)	(B)	(C)	(D)
-----	-----	-----	-----
- Your responses to the items are to be indicated in the **OMR Sheet given inside the Booklet only**. If you mark at any place other than in the circle in the OMR Sheet, it will not be evaluated.
- Read instructions given inside carefully.
- Rough Work is to be done at the end of this booklet.
- If you write your Name, Seat Number, Phone Number or put any mark on any part of the OMR Sheet, except for the space allotted for the relevant entries, which may disclose your identity, or use abusive language or employ any other unfair means, you will render yourself liable to disqualification.
- You have to return original OMR Sheet to the invigilator at the end of the examination compulsorily and must not carry it with you outside the Examination Hall. You are, however, allowed to carry the Test Booklet and duplicate copy of OMR Sheet on conclusion of examination.
- Use only Blue/Black Ball point pen.**
- Use of any calculator or log table, etc., is prohibited.**
- There is no negative marking for incorrect answers.**

विद्यार्थ्यांसाठी महत्त्वाच्या सूचना

- परिक्षार्थींनी आपला आसन क्रमांक या पृष्ठावरील वरच्या कोपऱ्यात लिहावा. तसेच आपणांस दिलेल्या उत्तरपत्रिकेचा क्रमांक त्याखाली लिहावा.
- सदर प्रश्नपत्रिकेत **75** बहुपर्यायी प्रश्न आहेत. प्रत्येक प्रश्नास **दोन** गुण आहेत. या प्रश्नपत्रिकेतील **सर्व** प्रश्न सोडविणे अनिवार्य आहे. सदरचे प्रश्न हे या विषयाच्या संपूर्ण अभ्यासक्रमावर आधारित आहेत.
- परीक्षा सुरु झाल्यावर विद्यार्थ्यांला प्रश्नपत्रिका दिली जाईल. सुरुवातीच्या 5 मिनीटांमध्ये आपण सदर प्रश्नपत्रिका उघडून खालील बाबी अवश्य तपासून घ्याव्यात.
 - प्रश्नपत्रिका उघडण्यासाठी प्रश्नपत्रिकेवर लावलेले सील उघडावे. सील नसलेली किंवा सील उघडलेली प्रश्नपत्रिका स्विकारू नये.
 - पहिल्या पृष्ठावर नमूद केल्याप्रमाणे प्रश्नपत्रिकेची एकूण पृष्ठे तसेच प्रश्नपत्रिकेतील एकूण प्रश्नांची संख्या पडताळून घ्यावी. पृष्ठे कमी असलेली/कमी प्रश्न असलेली/प्रश्नांचा चूकीचा क्रम असलेली किंवा इतर त्रुटी असलेली सदोष प्रश्नपत्रिका सुरुवातीच्या 5 मिनिटातच पर्यवेक्षकाला परत देऊन दुसरी प्रश्नपत्रिका मागवून घ्यावी. त्यानंतर प्रश्नपत्रिका बदलून मिळणार नाही तसेच वेळही वाढवून मिळणार नाही याची कृपया विद्यार्थ्यांनी नोंद घ्यावी.
 - वरीलप्रमाणे सर्व पडताळून पहिल्यानंतरच प्रश्नपत्रिकेवर ओ.एम.आर. उत्तरपत्रिकेचा नंबर लिहावा.
- प्रत्येक प्रश्नासाठी (A), (B), (C) आणि (D) अशी चार विकल्प उत्तरे दिली आहेत. त्यातील योग्य उत्तराचा रकाना खाली दर्शविल्याप्रमाणे ठळकपणे काळा/निळा करावा.
उदा. : जर (C) हे योग्य उत्तर असेल तर.

(A)	(B)	(C)	(D)
-----	-----	-----	-----
- या प्रश्नपत्रिकेतील प्रश्नांची उत्तरे ओ.एम.आर. उत्तरपत्रिकेतच दर्शवावीत. इतर ठिकाणी लिहिलेली उत्तरे तपासली जाणार नाहीत.
- आत दिलेल्या सूचना काळजीपूर्वक वाचाव्यात.
- प्रश्नपत्रिकेच्या शेवटी जोडलेल्या कोऱ्या पानावरच कच्चे काम करावे.
- जर आपण ओ.एम.आर. वर नमूद केलेल्या ठिकाणा व्यतिरिक्त इतर कोठेही नाव, आसन क्रमांक, फोन नंबर किंवा ओळख पटेल अशी कोणतीही खूप केलेली आढळून आल्यास अथवा असभ्य भाषेचा वापर किंवा इतर गैरमागाचा अवलंब केल्यास विद्यार्थ्यांला परीक्षेस अपात्र ठरविण्यात येईल.
- परीक्षा संपल्यानंतर विद्यार्थ्यांने मूळ ओ.एम.आर. उत्तरपत्रिका पर्यवेक्षकांकडे परत करणे आवश्यक आहे. तथापी, प्रश्नपत्रिका व ओ.एम.आर. उत्तरपत्रिकेची द्वितीय प्रत आपल्याबरोबर नेण्यास विद्यार्थ्यांना परवानगी आहे.
- फक्त निळा किंवा काळा बॉल पेनचाच वापर करावा.**
- कॅलक्युलेटर किंवा लॉग टेबल वापरण्यास परवानगी नाही.**
- चुकीच्या उत्तरासाठी गुण कपात केली जाणार नाही.**

JAN - 32318/III—B

PHYSICAL SCIENCE
Paper III

Time Allowed : 2½ Hours]

[Maximum Marks : 150

Note : This paper contains **Seventy Five (75)** multiple choice questions. Each question carries **Two (2)** marks. Attempt *All* questions.

- | | |
|---|---|
| <p>1. If a particle has the wave function $\psi = e^{ikz}$, the z-component of its angular momentum is :</p> <p>(A) $\hbar k$</p> <p>(B) Zero</p> <p>(C) $i\hbar k$</p> <p>(D) $-i\hbar k$</p> <p>2. The fourth excited state wave function of a one-dimensional infinite square well has.....nodes.</p> <p>(A) Three</p> <p>(B) Four</p> <p>(C) Five</p> <p>(D) Six</p> | <p>3. A particle is represented by a plane wave in position space. Its wave function in momentum space is :</p> <p>(A) a delta function</p> <p>(B) a plane wave</p> <p>(C) a Gaussian function</p> <p>(D) a Lorentzian function</p> <p>4. Consider two spin 1/2 particles having spin angular momentum operators \vec{s}_1 and \vec{s}_2. The expectation value of the product $\vec{s}_1 \cdot \vec{s}_2$ in the singlet state is :</p> <p>(A) $-\frac{3}{8}\hbar^2$</p> <p>(B) $\frac{3}{8}\hbar^2$</p> <p>(C) $1\hbar^2$</p> <p>(D) Zero</p> |
|---|---|

5. A one-dimensional harmonic oscillator in ground state is subjected to time dependent perturbation $V(t) = 0$ for $t < 0$; $V(t) = xe^{-at}$ for $t > 0$. The probability that the system is in third excited state at $t = \infty$ is :

- (A) $1/3$
- (B) 1
- (C) Zero
- (D) $e^{-a/3}$

6. Two identical blocks of a metal with heat capacity C are initially at temperatures T_1 and T_2 , ($T_1 < T_2$). They are brought in thermal contact. When the system reaches equilibrium the change in entropy would be :

- (A) $C \ln \left(\frac{(T_1 + T_2)^2}{T_1 T_2} \right)$
- (B) $C \ln \left(\frac{(T_1 + T_2)^2}{4T_1 T_2} \right)$
- (C) $C \ln \left(\frac{T_1 T_2}{(T_1 + T_2)^2} \right)$
- (D) $C \ln \left(\frac{(T_1 + T_2)^2}{2T_1 T_2} \right)$

7. For a quantum mechanical system of N identical spin – $1/2$ particles in one-dimensional box of length L , the Fermi wave number is :

- (A) $k_F = \frac{N}{L}$
- (B) $k_F = \frac{\pi N}{2L}$
- (C) $k_F = \frac{N}{2L}$
- (D) $k_F = \frac{\pi N}{L}$

8. A system consists of two indistinguishable bosons. Each particle can occupy only two energy levels $E = \epsilon$ and $E = 2\epsilon$. The canonical partition function for the system is :

- (A) $Z = e^{-4\beta\epsilon} + e^{-3\beta\epsilon} + e^{-2\beta\epsilon}$
- (B) $Z = e^{-6\beta\epsilon}$
- (C) $Z = e^{-3\beta\epsilon}$
- (D) $Z = e^{-9\beta\epsilon}$

9. Consider a reversible expansion of an ideal gas from volume V_1 to $4V_1$ while keeping contact with a heat reservoir of temperature T . The heat drawn from the reservoir is equal to :

- (A) $2Nk_B T \ln 2$
- (B) $Nk_B T \ln 2$
- (C) $-2Nk_B T \ln 2$
- (D) $-Nk_B T \ln 2$

10. The partition function of a two-dimensional oscillator whose energy $E_{n_x n_y} = (n_x + n_y + 1)\hbar\omega$, $n_x = 0, 1, 2, \dots$; $n_y = 0, 1, 2, \dots$, is :

- (A) $\frac{e^{\frac{\hbar\omega}{2k_B T}}}{\left(e^{\frac{\hbar\omega}{2k_B T} - 1}\right)^2}$
- (B) $\frac{e^{\frac{\hbar\omega}{k_B T}}}{\left(e^{\frac{\hbar\omega}{2k_B T} - 1}\right)^2}$
- (C) $\frac{e^{\frac{\hbar\omega}{k_B T}}}{\left(e^{\frac{\hbar\omega}{k_B T} - 1}\right)^2}$
- (D) $\frac{e^{\frac{\hbar\omega}{k_B T}}}{\left(e^{\frac{\hbar\omega}{2k_B T} + 1}\right)^2}$

11. Consider a closed system is subdivided into two subsystems 1 and 2, which are connected such that internal energy and particles may be exchanged and volume of the two remain constant. Under this condition the minimum value of the quantity $\left(\frac{dU_1}{dN_1}\right)$ is given by (here μ 's and T 's are the respective chemical potential and temperature) :

- (A) $\frac{\mu_1 T_2 - \mu_2 T_1}{T_2 - T_1}$
- (B) $\frac{\mu_1 T_2 + \mu_2 T_1}{T_2 - T_1}$
- (C) $\frac{\mu_1 T_2 - \mu_2 T_1}{T_2 + T_1}$
- (D) $\frac{\mu_1 T_2 + \mu_2 T_1}{T_1 + T_2}$

12. Which of the following figures depicts the practical pumping chart of a Rotary pump having a pumping speed of 100 L/min ?

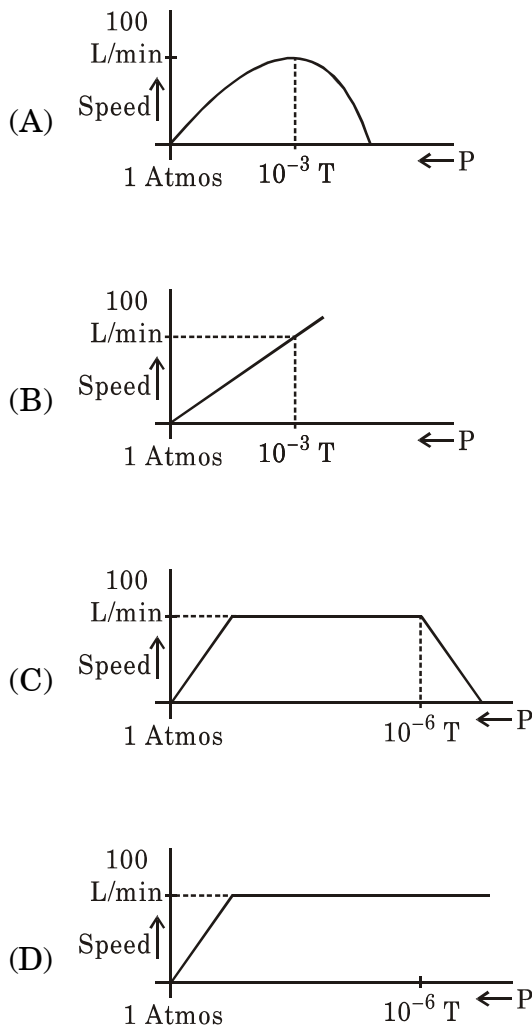

13. Which of the following devices operates under forward bias ?

- (A) Zener diode
- (B) Tunnel diode
- (C) Photodiode
- (D) Light emitting diode

14. An AC bridge of De-Sauty's is used to measure the capacitance. A supply of 450 Hz is used. The bridge is balanced when $C_2 = 0.5 \mu\text{F}$. The values of R_1, R_2, R_3 and R_4 are 0.5, 5, 1000 and 2000 ohms respectively. What is the value of C_1 ?

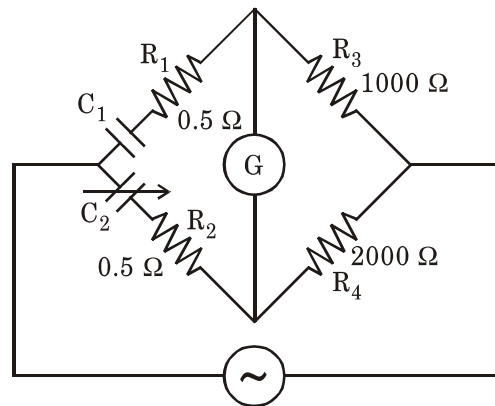

- (A) $0.5 \mu\text{F}$
- (B) $1.0 \mu\text{F}$
- (C) $5.0 \mu\text{F}$
- (D) $0.2 \mu\text{F}$

15. Which one of the following has the highest resolving power in the visible region of electromagnetic spectrum ?

- (A) Triangular prism
- (B) Constant deviation prism
- (C) Grating
- (D) Fabry-Perot etalon

16. An X-ray diffraction pattern of cubic crystal of lattice parameter $a = 3.16 \text{ \AA}$ is obtained using a monochromatic X-ray beam of wavelength 1.54 \AA . The first line is obtained at $\theta = 20.3$. The Miller indices (hkl value) of the corresponding diffracting plane is :

(Note : $\sin 20.3 = 0.34$,
 $\sin 40.6 = 0.64$)

- (A) 110
- (B) 200
- (C) 100
- (D) 220

17. The instrumental broadening of an X-ray diffractometer arising from non-monochromatic beam can be written as :

- (A) $\alpha d \sin \theta$
- (B) $\alpha \frac{1}{d \cos \theta}$
- (C) $\alpha 2\theta$
- (D) $\alpha \frac{1}{d \sin \theta}$

18. In the following circuit, if $R_L = R_C = 10 \text{ k}\Omega$, then the value of V_o will be :

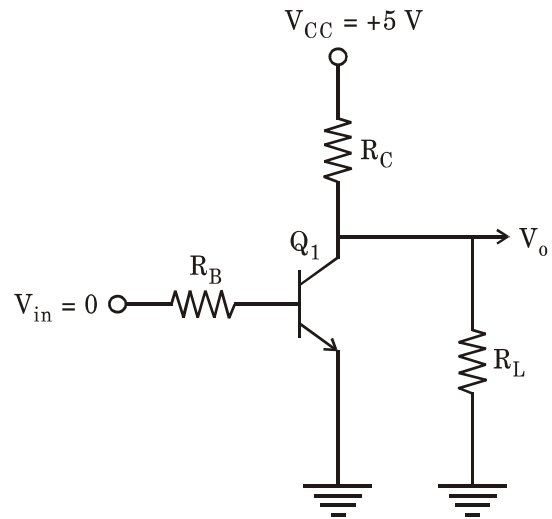

- (A) 4.55 V
- (B) 2.5 V
- (C) 1.0 V
- (D) Zero

19. The output waveform for the following OP-Amp configuration is :

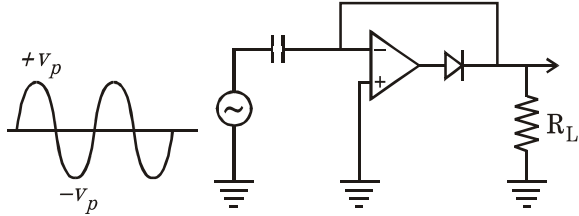

- (A)
- (B)
- (C)
- (D)

20. In the following OP-Amp circuit

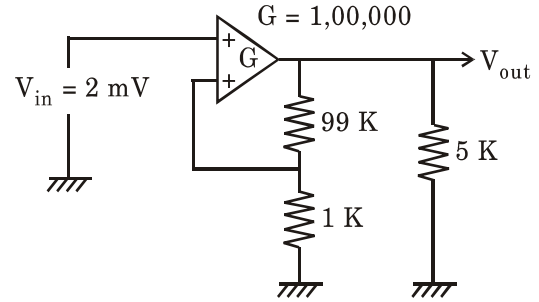

The output voltage V_{out} will be :

- (A) 100 mV
- (B) 200 mV
- (C) 300 mV
- (D) 500 mV

21. The resonant frequency of the following tuned-collector oscillator is 6 MHz. If the value of the tuned circuit capacitor increased by 50%, the new resonant frequency of the oscillator will be around :

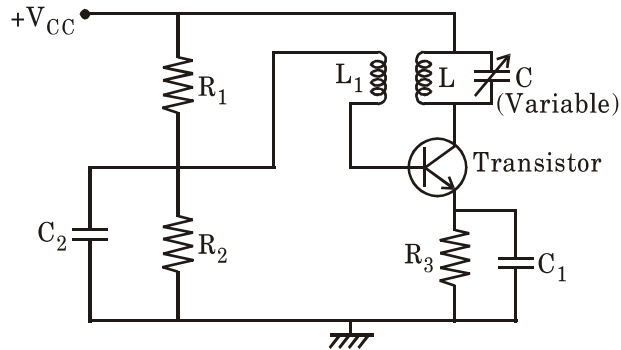

- (A) 3 MHz
- (B) 6.98 MHz
- (C) 4.89 MHz
- (D) 5.89 MHz

22. In the following Zener regulator circuit, the current through Zener diode I_z is equal to :

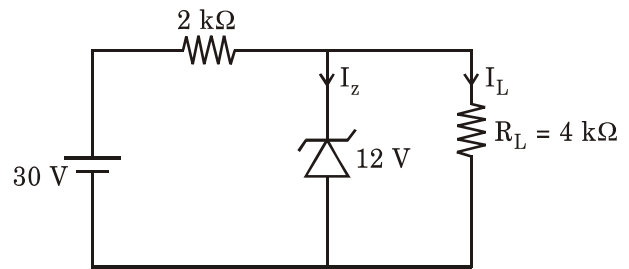

- (A) 4 mA
- (B) 6 mA
- (C) 8 mA
- (D) 10 mA

23. A 8-bit counter type A to D converter is driven by 500 kHz clock frequency. The conversion time is :
- (A) 256 μsec
 (B) 512 μsec
 (C) 1024 μsec
 (D) 2048 μsec
24. In a frequency modulation network, the carrier swing is 240 kHz. If the modulation signal frequency is kHz, the modulation index of the F.M. carrier will be :
- (A) 10
 (B) 12
 (C) 14
 (D) 16
25. The most important mode of operation of magnetron is one where in the phase shift between the electric fields of adjacent cavities is :
- (A) $\pi/4$
 (B) $\pi/2$
 (C) π
 (D) $3/2\pi$
26. A 'D' Flip-Flop has the following data sheet : Information setup time = 5 nsec; hold time = 10 nsec; propagation time = 15 nsec. The output will change after the clock edge in a period of :
- (A) 5 nsec
 (B) 10 nsec
 (C) 15 nsec
 (D) 20 nsec

27. Using Boolean equation, the output

'Y' of the network shown below is

equal to :

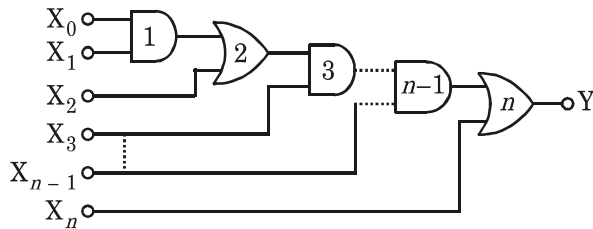

- (A) $X_0X_1X_2\dots X_n + X_1X_2\dots X_n$
 $+ X_2X_3\dots X_n + X_n$
- (B) $X_0X_1 + X_2X_3 + \dots + X_{n-1}X_n$
- (C) $X_0 + X_1 + X_2 + \dots + X_n$
- (D) $X_0X_1X_3\dots X_{n-1} + X_2X_3X_5$
 $\dots X_{n-1} + X_{n-2}X_{n-1} + X_n$

28. For a singlet state of electronic system, the Landé splitting factor will be equal to :

- (A) 3/2
 (B) 5/2
 (C) 1/2
 (D) 1

29. The orbital angular momentum of a single 2s electron is (h is the Planck's constant) :

- (A) $h/2\pi$
 (B) $h/4\pi$
 (C) $h\sqrt{2} / 2\pi$
 (D) Zero

30. The selection rules for vibrational Raman spectra and rotational Raman spectra are :
- (A) $\Delta v = 0, \pm 1$ and $\Delta I = 0, \pm 1$ respectively
- (B) $\Delta v = \pm 1$ and $\Delta J = 0, \pm 1$ respectively
- (C) $\Delta v = \pm 1$ and $\Delta J = 0, \pm 2$ respectively
- (D) $\Delta v = 0, \pm 1$ and $\Delta J = 0, \pm 2$ respectively
31. Consider a source which emits radiation of 500 nm wavelength. The linewidth of the emitted radiation is 1 nm. The coherence length $|l_c|$ is :
- (A) 2.5 μm
- (B) 250 μm
- (C) 1.0 μm
- (D) 100 μm
32. The total number of electrons in d orbital in Fe^{2+} ion (atomic number of Fe is 26) is not equal to that of the total number of :
- (A) p electrons in Ne atom (Atomic number 10)
- (B) d electrons in Fe atom
- (C) p electrons in Cl^- ion (Atomic number 17)
- (D) s electrons of Mg (Atomic number 12)
33. The shortest wavelength observed in Paschen back series of hydrogen spectra is ($R_H = 10967757.6 \text{ m}^{-1}$)
- (A) 7800 \AA
- (B) 7349 \AA
- (C) 9546 \AA
- (D) 8205 \AA

34. The hypothetical equilibrium oscillation frequency ω_e of HCl molecule, considered as an anharmonic oscillator, is equal to 2990 cm^{-1} . If the anharmonicity constant x_e is equal to 0.01, then the first absorption line will be obtained at :
- (A) 2990 cm^{-1}
 (B) 29.90 cm^{-1}
 (C) 2886 cm^{-1}
 (D) 2960 cm^{-1}
35. The possible values of j and m_j for a single d electron system would be :
- (A) $j = 2, 1$ and $m_j = \frac{5}{2}$ and $\frac{3}{2}$
 (B) $j = \frac{5}{2}$ and $\frac{3}{2}$ and

$$m_j = \frac{5}{2}, \frac{3}{2}, \frac{1}{2}, \frac{-1}{2}, \frac{-3}{2}, \frac{-5}{2}$$

 (C) $j = 3$ and 2 and

$$m_j = 3, 2, 1, 0, -1, -2, -3$$

 (D) $j = \frac{5}{2}$ and $\frac{3}{2}$ and

$$m_j = 5, 3, 1, -1, -3, -5$$
36. The rotational spectrum of a molecule is sensitive to isotopic substitution of atoms in the molecule. If the ratio of the rotational constant B' of $^{13}\text{C}^{16}\text{O}$ to the constant B of $^{12}\text{C}^{16}\text{O}$ is 0.956; and if the first rotational line for $^{12}\text{C}^{16}\text{O}$ is observed at 3.84 cm^{-1} , that for $^{13}\text{C}^{16}\text{O}$ will be observed at :
- (A) 4.79 cm^{-1}
 (B) 2.89 cm^{-1}
 (C) 3.87 cm^{-1}
 (D) 3.67 cm^{-1}
37. Which of the following cubic structure is most loosely packed ?
- (A) Simple
 (B) Body centered
 (C) Face centered
 (D) Diamond

38. The Fermi-momentum and dimension of a mono-atomic 2D square crystal are given by k_F and L . If each atom is contributing one electron to the Fermi gas, the size of the primitive cell is :
- (A) $\frac{2\pi}{k_F^2}$
- (B) $\frac{\pi}{k_F^2}$
- (C) $\frac{L\pi}{k_F}$
- (D) $\frac{2L\pi}{k_F}$
39. The ratio of skin depth in copper at 1 kHz to that at 100 MHz is approximately :
- (A) 3
- (B) 30
- (C) 300
- (D) 3000
40. Density of states in conduction band for electrons assumed to be essentially free in two dimensions is proportional to :
- (A) $E^{1/2}$
- (B) E^0 *i.e.* independent of energy
- (C) $E^{-1/2}$
- (D) E^{-1}
41. In an allowed band of semiconductor the effective mass m^* of the electron is infinite :
- (A) at the bottom of energy band
- (B) at the top of energy band
- (C) in the middle of the energy band
- (D) never

42. In an anti-ferromagnet, susceptibility χ above Neel temperature θ

has a form :

(A) $\chi = \frac{2c}{T+\theta}$

(B) $\chi = 2\alpha(T + \theta)$

(C) $\chi = \frac{2c}{T-\theta}$

(D) $\chi = 2\alpha(T - \theta)$

43. According to Hund's rule, the value of total angular momentum J is S when :

(A) shell is less than half full

(B) shell is more than half full

(C) shell is just half full

(D) shell is completely full

44. Superconductors are perfect diamagnets with susceptibility χ in CGS units to be :

(A) $-1/4\pi$

(B) 10^{-6}

(C) 10^6

(D) 4π

45. Quartz and Barium titanate are piezoelectric. The *correct* statement from below is :

(A) Both Quartz and Barium titanate are ferroelectric

(B) Quartz is ferroelectric but Barium titanate is not

(C) Barium titanate is ferroelectric but Quartz is not

(D) Neither Quartz nor Barium titanate are ferroelectric

46. A rare gas inter-atomic potential is given by $U(r) = \frac{A}{r^{12}} - \frac{B}{r^6}$, where A and B are material parameters.

What is the spring constant for displacement of atoms in the harmonic limit, if the given equilibrium separation r_0 is 1 au :

- (A) $156A - 42B$
- (B) $42A - 156B$
- (C) $12A - 6B$
- (D) $-12A + 6B$

47. The following nuclear reaction is induced by bombarding neutrons on ^{13}C target.

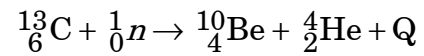

The mass are given below in a.m.u.

[one amu = 931.494 MeV]. The threshold energy of the reaction is :

- (A) 3.04 MeV
- (B) 4.13 MeV
- (C) 6.511 MeV
- (D) 8.83 MeV

48. In the fission of U-235 nuclei, it is observed that the fission fragments decay by emission of negatively charged beta particles and attain state of stable nuclei.

The reason for emission of negatively charged beta particles is that the fission fragments :

- (A) have different mass numbers and high values of spins
- (B) are rich in protons
- (C) emit prompt neutrons
- (D) are rich in neutrons

49. If the nucleus A has radius twice as that of ^{27}Al nucleus, then the ratio of the nucleon number of nucleus A to that of ^{27}Al nucleus will be :

- (A) 16
- (B) 8
- (C) 40
- (D) 14

50. The radioactive $^{210}_{84}\text{Po}$ emits alpha particles through the following decay process :

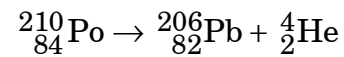

(Alpha Particle)

The height of the potential barrier experienced by the alpha particle emitted from radioactive nuclei $^{210}_{84}\text{Po}$ is equal to :

- (A) 26 MeV
- (B) 40 MeV
- (C) 80 MeV
- (D) 42 MeV

51. When U-235 nucleus is fissioned, energy is released in addition to the emission of fission fragments. In fission, the energy is released because :

- (A) the binding energy of each fission fragment is greater than that of U-235 nucleus
- (B) the binding energy of each fission fragment is smaller than that of U-235 nucleus
- (C) the sum of the binding energies of the fission fragments is equal to the binding energy of U-235 nucleus
- (D) the difference in the binding energies of the fission fragments is equal to the binding energy of U-235 nucleus

52. Energetic particle K^- interacts with proton and induces the following reaction

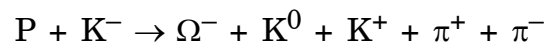

By assigning strangeness number to all other particles, the estimated strangeness of Ω^- particle is :

- (A) +3
- (B) -3
- (C) +2
- (D) -2

53. The following nuclear reaction

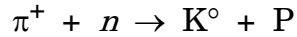

is examined on the basis of conservation laws of charge, Baryon number, strangeness and third component of Isospin. It is observed that the reaction cannot be induced due to non-conservation of the :

- (A) Charge and strangeness
- (B) Baryon number and charge
- (C) Third component of Isospin and Baryon number
- (D) Strangeness and third component of Isospin

54. An excited nucleus decayed from an energy level having spin and parity of 3^+ to another energy level having spin and parity of 0^+ by emitting a beta particle. The above beta-decay has the prominent decay mode of :

- (A) First Forbidden-Gamow-Teller transition
- (B) Second Forbidden-Gamow-Teller transition
- (C) Allowed Fermi transition
- (D) Allowed Gamow-Teller transition

55. In the energy levels predicted by shell model, the labelled energy states and the corresponding nucleon number, starting from the lowest to higher energy levels are as follows :

- (i) $1s_{1/2}$ – 2 Nucleons
- (ii) $1p_{3/2}$ – 4 Nucleons
- (iii) $1p_{1/2}$ – 2 Nucleons
- (iv) $1d_{5/2}$ – 6 Nucleons

The estimated groundstate spins of ${}^{27}_{13}\text{Al}$ and ${}^{11}_5\text{B}$ nuclei are :

- (A) ${}^{11}_5\text{B} \rightarrow \left(\frac{1}{2}\right)$ and ${}^{27}_{13}\text{Al} \rightarrow \left(\frac{3}{2}\right)$
- (B) ${}^{11}_5\text{B} \rightarrow \left(\frac{3}{2}\right)$ and ${}^{27}_{13}\text{Al} \rightarrow \left(\frac{5}{2}\right)$
- (C) ${}^{11}_5\text{B} \rightarrow \left(\frac{5}{2}\right)$ and ${}^{27}_{13}\text{Al} \rightarrow \left(\frac{1}{2}\right)$
- (D) ${}^{11}_5\text{B} \rightarrow \left(\frac{11}{2}\right)$ and ${}^{27}_{13}\text{Al} \rightarrow \left(\frac{7}{2}\right)$

56. Given that Fourier integral representation for the function

$$f(x) = \begin{cases} 0 & \text{if } |x| > 1 \\ 1 & \text{if } |x| < 1 \end{cases}$$

$$\text{is } f(x) = \frac{2}{\pi} \int_0^{\infty} \frac{\cos \omega x \sin \omega}{\omega} d\omega$$

Which of the following options is correct ?

$$(A) \int_0^{\infty} \frac{\cos \omega x \sin \omega}{\omega} d\omega$$

$$= \begin{cases} \pi/2 & \text{if } 0 \leq x < 1 \\ \pi/4 & \text{if } x = 1 \\ 0 & \text{if } x > 1 \end{cases}$$

$$(B) \int_0^{\infty} \frac{\sin \omega}{\omega} d\omega = \pi$$

$$(C) \int_0^{\infty} \frac{\sin \omega}{\omega} d\omega = \frac{\pi}{4}$$

$$(D) \int_0^{\infty} \frac{\cos \omega x \sin \omega}{\omega} d\omega = 0$$

57. The series $1 + \frac{1}{2^s} + \frac{1}{3^s} + \frac{1}{4^s} + \dots$

- (A) Converges for all values of s
- (B) Converges for $s > 1$
- (C) Converges for $s < 0$
- (D) Diverges for all values of s

58. The eigen values of an anti-Hermitian matrix are :

- (A) Real positive
- (B) Real negative
- (C) Purely imaginary
- (D) Have non-zero real part

59. The radius of convergence of the

series $\sum_{n=0}^{\infty} \frac{(2n)!}{(n!)^2} (z - 3i)^n$ is :

- (A) Infinity
- (B) $\frac{1}{2}$
- (C) 2
- (D) $\frac{1}{4}$

60. The solutions of the differential equation $\frac{d^2x}{dt^2} - \frac{dx}{dt} + x = 0$:

- (A) will tend to ∞ as $t \rightarrow \infty$
- (B) will tend to $-\infty$ as $t \rightarrow \infty$
- (C) will tend to 0 as $t \rightarrow \infty$
- (D) will oscillate with finite amplitude for all t

61. For a simple harmonic oscillator the probability of finding the particle, if the measurement is made at random time, is inversely proportional to the speed. If the amplitude of oscillation is A , the probability of finding the particle is :

- (A) Maximum close to $\pm A$
- (B) Maximum at zero
- (C) Constant on closed interval $[-A, A]$
- (D) Maximum at $\pm A/2$

62. Let V be a 5-dimensional vector space and V_1 and V_2 be subspaces of V which are 3-dimensional each. Then the dimension of $V_1 \wedge V_2$ is :
- (A) 3
 (B) 0
 (C) 1
 (D) 2
63. A man jumps from a height in a deep pool of water. If the net frictional force of water F is proportional to the instantaneous speed V of the man, *i.e.*, $F = kV$; what is the terminal velocity of the man ? The mass of the man is m .
- (A) mg/k
 (B) $2 mg/k$
 (C) $\frac{1}{2} mg/k$
 (D) $\frac{3}{2} mg/k$
64. Consider a system comprising of sun, earth and moon. What is the orbit of moon around sun ?
- (A) ellipse
 (B) elliptical spiral
 (C) preceding ellipse
 (D) cycloid
65. The degree of freedom of a simple pendulum whose point of support is constrained to move on inner surface of a hollow sphere are :
- (A) 2
 (B) 3
 (C) 4
 (D) 5

66. For a system with n degrees of freedom, the Poisson's bracket $[x_i, p_j]$ is :

- (A) Zero
- (B) δ_{ij}
- (C) $\delta_{ij}\delta_{jk}p_k$
- (D) $-\delta_{ij}$

67. A block of mass m slides down an inclined plane at constant speed, from initial rest position at height h above the ground. The angle of inclination is θ and coefficient of kinetic friction is μ . The energy dissipated by friction by the time the mass reaches the ground is :

- (A) Zero
- (B) mgh
- (C) mgh/μ
- (D) μmgh

68. A man of mass m in an initially stationary boat of mass M gets off the boat by jumping to the left in an exact horizontal direction.

Immediately after the jump, the boat is observed to be moving to the right at speed v . How much total work did the man do ? (Neglect friction)

- (A) $\frac{1}{2}Mv^2$
- (B) $\frac{1}{2}mv^2$
- (C) $\frac{1}{2}(M + m)v^2$
- (D) $\frac{1}{2}\left(M + \frac{M^2}{m}\right)v^2$

69. A point charge q is placed at $z = a$ on the z -axis. There is an infinite grounded conducting plane at $z = 0$.

What is the total electrostatic energy stored ?

(A) $\frac{q^2}{8\pi \epsilon_0 a}$

(B) $\frac{-q^2}{8\pi \epsilon_0 a}$

(C) $\frac{q^2}{16\pi \epsilon_0 a}$

(D) $\frac{-q^2}{16\pi \epsilon_0 a}$

70. A point charge q is placed at a corner of a cube of side-length l .

The electric flux through one of the cube faces not passing through the

charge q is :

(A) $\frac{ql^2}{\epsilon_0}$

(B) $\frac{q}{3\epsilon_0}$

(C) $\frac{q}{6\epsilon_0}$

(D) $\frac{q}{24\epsilon_0}$

71. An infinitely long wire carrying current I is placed along x -axis. The Cartesian coordinates of points P and Q are $(0, 0, -3)$ and $(3, 0, 6)$ respectively. If \vec{B}_P and \vec{B}_Q are the magnetic fields at the points P and Q respectively, then :

- (A) $\vec{B}_P = 2\vec{B}_Q$
- (B) $\vec{B}_P = -2\vec{B}_Q$
- (C) $\vec{B}_P = 4\vec{B}_Q$
- (D) $\vec{B}_P = -4\vec{B}_Q$

72. The values of conductivity g and permittivity ϵ of the conducting material are such that angular frequency ω of the electromagnetic wave is much smaller than $\left(\frac{g}{|\epsilon|}\right)$ *i.e.*, $\omega \ll \left(\frac{g}{|\epsilon|}\right)$. The phase difference between the fields \vec{E} and \vec{B} associated with the electromagnetic wave passing through the material is :

- (A) Zero
- (B) $\pi/4$
- (C) $\pi/2$
- (D) π

73. Two infinite plates made up of perfect conducting material are held parallel to each other with finite separation between them. In the gap region, an electromagnetic radiation is so introduced that it strikes the plates with angle of incidence θ . The energy propagates with the speed :

(A) $c \cos \theta$

(B) $\frac{c}{\cos \theta}$

(C) $c \sin \theta$

(D) $\frac{c}{\sin \theta}$

74. A tiny oscillating magnetic dipole is formed by circulating sinusoidal current in a circular loop in the xz -plane, with center at origin. Consider this as a perfect dipole. Power radiated by the dipole is minimum along :

(A) x -axis

(B) y -axis

(C) z -axis

(D) $\hat{x}\hat{x} + \hat{z}\hat{z}$

75. Which of the following operator commutes with Hamiltonian of one-dimensional oscillator. x and P_x are position and momentum operators, a and a^+ are annihilation and creation operators :

(A) a

(B) a^+

(C) P_x

(D) a^+a

JAN - 32318/III—B

ROUGH WORK

JAN - 32318/III—B

ROUGH WORK