

Test Booklet No.

प्रश्नपत्रिका क्र.

M

Paper-III PHYSICS

Seat No.

| | | | | | | | |
|--|--|--|--|--|--|--|--|
| | | | | | | | |
|--|--|--|--|--|--|--|--|

(In figures as in Admit Card)

Seat No.

(In words)

OMR Sheet No.

| | | | | | | | |
|--|--|--|--|--|--|--|--|
| | | | | | | | |
|--|--|--|--|--|--|--|--|

(To be filled by the Candidate)

Signature and Name of Invigilator

1. (Signature)

(Name)

2. (Signature)

(Name)

DEC - 32313

Time Allowed : 2½ Hours]

[Maximum Marks : 150

Number of Pages in this Booklet : 20

Number of Questions in this Booklet : 75

Instructions for the Candidates

- Write your Seat No. and OMR Sheet No. in the space provided on the top of this page.
- This paper consists of 75 objective type questions. Each question will carry two marks. All questions of Paper-III will be compulsory, covering entire syllabus (including all electives, without options).
- At the commencement of examination, the question booklet will be given to the student. In the first 5 minutes, you are requested to open the booklet and compulsorily examine it as follows :
 - To have access to the Question Booklet, tear off the paper seal on the edge of this cover page. Do not accept a booklet without sticker-seal or open booklet.
 - Tally the number of pages and number of questions in the booklet with the information printed on the cover page. Faulty booklets due to missing pages/questions or questions repeated or not in serial order or any other discrepancy should not be accepted and correct booklet should be obtained from the invigilator within the period of 5 minutes. Afterwards, neither the Question Booklet will be replaced nor any extra time will be given. The same may please be noted.**
 - After this verification is over, the OMR Sheet Number should be entered on this Test Booklet.
- Each question has four alternative responses marked (A), (B), (C) and (D). You have to darken the circle as indicated below on the correct response against each item.
Example : where (C) is the correct response.

| | | | |
|-----|-----|-----|-----|
| (A) | (B) | (C) | (D) |
|-----|-----|-----|-----|
- Your responses to the items are to be indicated in the **OMR Sheet given inside the Booklet only**. If you mark at any place other than in the circle in the OMR Sheet, it will not be evaluated.
- Read instructions given inside carefully.
- Rough Work is to be done at the end of this booklet.
- If you write your Name, Seat Number, Phone Number or put any mark on any part of the OMR Sheet, except for the space allotted for the relevant entries, which may disclose your identity, or use abusive language or employ any other unfair means, you will render yourself liable to disqualification.
- You have to return original OMR Sheet to the invigilator at the end of the examination compulsorily and must not carry it with you outside the Examination Hall. You are, however, allowed to carry the Test Booklet and duplicate copy of OMR Sheet on conclusion of examination.
- Use only Blue/Black Ball point pen.
- Use of any calculator or log table, etc., is prohibited.
- There is no negative marking for incorrect answers.

विद्यार्थ्यांसाठी महत्वाच्या सूचना

- परिक्षार्थींनी आपला आसन क्रमांक या पृष्ठावरील वरच्या कोपऱ्यात लिहावा. तसेच आपणांस दिलेल्या उत्तरपत्रिकेचा क्रमांक त्याखाली लिहावा.
- सदर प्रश्नपत्रिकेत 75 बहुपर्यायी प्रश्न आहेत. प्रत्येक प्रश्नास दोन गुण आहेत. या प्रश्नपत्रिकेतील सर्व प्रश्न सोडविणे अनिवार्य आहे. सदरचे प्रश्न हे या विषयाच्या संपूर्ण अभ्यासक्रमावर आधारित आहेत.
- परीक्षा सुरु झाल्यावर विद्यार्थ्यांला प्रश्नपत्रिका दिली जाईल. सुरुवातीच्या 5 मिनीटांमध्ये आपण सदर प्रश्नपत्रिका उघडून खालील बाबी अवश्य तपासून घ्याव्यात.
 - प्रश्नपत्रिका उघडण्यासाठी प्रश्नपत्रिकेवर लावलेले सील उघडावे. सील नसलेली किंवा सील उघडलेली प्रश्नपत्रिका स्विकारू नये.
 - पहिल्या पृष्ठावर नमूद केल्याप्रमाणे प्रश्नपत्रिकेची एकूण पृष्ठे तसेच प्रश्नपत्रिकेतील एकूण प्रश्नांची संख्या पडताळून घ्यावी. पृष्ठे कमी असलेली/कमी प्रश्न असलेली/प्रश्नांचा चुकीचा क्रम असलेली किंवा इतर त्रुटी असलेली सदोष प्रश्नपत्रिका सुरुवातीच्या 5 मिनिटातच पर्यवेक्षकाला परत देऊन दुसरी प्रश्नपत्रिका मागवून घ्यावी. त्यानंतर प्रश्नपत्रिका बदलून मिळणार नाही तसेच वेळी वाढवून मिळणार नाही याची कृपया विद्यार्थ्यांनी नोंद घ्यावी.
 - वरीलप्रमाणे सर्व पडताळून पहिल्यानंतरच प्रश्नपत्रिकेवर ओ.एम.आर. उत्तरपत्रिकेचा नंबर लिहावा.
- प्रत्येक प्रश्नासाठी (A), (B), (C) आणि (D) अशी चार विकल्प उत्तरे दिली आहेत. त्यातील योग्य उत्तराचा रकाना खाली दर्शविल्याप्रमाणे ठळकपणे काळा/निळा करावा.
उदा. : जर (C) हे योग्य उत्तर असेल तर.

| | | | |
|-----|-----|-----|-----|
| (A) | (B) | (C) | (D) |
|-----|-----|-----|-----|
- या प्रश्नपत्रिकेतील प्रश्नांची उत्तरे ओ.एम.आर. उत्तरपत्रिकेतच दर्शवावीत. इतर ठिकाणी लिहिलेली उत्तरे तपासली जाणार नाहीत.
- आत दिलेल्या सूचना काळजीपूर्वक वाचाव्यात.
- प्रश्नपत्रिकेच्या शेवटी जोडलेल्या कोऱ्या पानावरच कच्चे काम करावे.
- जर आपण ओ.एम.आर. वर नमूद केलेल्या ठिकाणा व्यतिरिक्त इतर कोठेही नाव, आसन क्रमांक, फोन नंबर किंवा ओळख पटेल अशी कोणतीही खूण केलेली आढळून आल्यास अथवा असभ्य भाषेचा वापर किंवा इतर गैरमार्गाचा अवलंब केल्यास विद्यार्थ्यांला परीक्षेस अपात्र ठरविण्यात येईल.
- परीक्षा संपल्यानंतर विद्यार्थ्यांनी मूळ ओ.एम.आर. उत्तरपत्रिका पर्यवेक्षकांकडे परत करणे आवश्यक आहे. तथापी, प्रश्नपत्रिका व ओ.एम.आर. उत्तरपत्रिकेची द्वितीय प्रत आपल्याबरोबर नेण्यास विद्यार्थ्यांना परवानगी आहे.
- फक्त निळा किंवा काळा बॉल पेनचाच वापर करावा.
- कॅलक्युलेटर किंवा लॉग टेबल वापरण्यास परवानगी नाही.
- चुकीच्या उत्तरासाठी गुण कपात केली जाणार नाही.

DEC-32313/III

PHYSICS**Paper III****Time Allowed : 2½ Hours]****[Maximum Marks : 150**

Note : This Paper contains **Seventy Five (75)** multiple choice questions. Each question carries **Two (2)** marks. Attempt *All* questions.

| | |
|---|---|
| <p>1. The polar plot of the equation</p> $r = a\theta$ <p>represents :</p> <p>(A) circle</p> <p>(B) spiral</p> <p>(C) gaussian</p> <p>(D) parabola</p> <p>2. The minimum order of the polynomial that fits exactly to 5 data set points is :</p> <p>(A) 1 (linear)</p> <p>(B) 2 (quadratic)</p> <p>(C) 4 (quartic)</p> <p>(D) 5 (quintic)</p> | <p>3. A coin is loaded such that “heads” occur with twice the frequency as “tails” when it is tossed. A second coin is an ideal coin. What is the probability that when both the coins are tossed simultaneously two “tails” would occur ?</p> <p>(A) 0.167</p> <p>(B) 0.333</p> <p>(C) 0.5</p> <p>(D) 0.25</p> <p>4. The value of $\nabla^2(r^2)$ is :</p> <p>(A) 3</p> <p>(B) 6</p> <p>(C) $2r$</p> <p>(D) zero</p> |
|---|---|

5. $y(x)$ satisfies the differential equation.

$$\frac{d^2y}{dx^2} - 2\frac{dy}{dx} + y = 0$$

One solution of this equation is Ae^x .
The second linearly independent solution is :

- (A) e^{-x}
 (B) xe^x
 (C) xe^{-x}
 (D) $x^2 + x$
6. $f(z) = \frac{1}{z^2 + a^2}$, $a > 0$. The integral of $f(z)$ over a contour comprising the real axis a semi-circle of infinite radius in the upper half plane is :

- (A) $\frac{2\pi}{a}$
 (B) $\frac{2\pi i}{a}$
 (C) $\frac{\pi}{a}$
 (D) zero

7. Consider a simple pendulum oscillating in a plane. The pendulum bob has mass m and is suspended by string of length ' l '. If θ is the angle made by the string with the vertical, then the kinetic energy of the system in plane polar coordinates is given by :

- (A) $T = \frac{1}{2} ml^2$
 (B) $T = mgl \cos\theta$
 (C) $T = \frac{1}{2} ml^2 \dot{\theta}^2$
 (D) $T = \frac{1}{2} m \dot{\theta}^2$

8. The conjugate momentum p_θ of a simple pendulum of mass m suspended from a support by a string of length l is given by :

- (A) $ml\dot{\theta}$
 (B) $m\dot{\theta}$
 (C) $ml^2\dot{\theta}$
 (D) ml^2

9. If two particles of equal mass m collide elastically with each other and scatter off, then the following statement is correct in the center of mass frame :
- (A) the velocities of the two particles are interchanged after the collision
- (B) the magnitudes of the velocities of the two particles are unchanged by the collision
- (C) the two particles move off together after the collision
- (D) the particle with the larger velocity comes to a rest, whereas the other particle stays in motion
10. If a particle of mass m moves under the action of a gravitational potential $V(r) = -\frac{MG}{R}$, then the following statement is *correct* :
- (A) The motion of the system is confined to a plane
- (B) The energy of the system is the only conserved quantity
- (C) The motion of the particle is always bounded
- (D) There are no initial conditions for which the particle can be execute uniform circular motion

11. Consider the motion of a planet moving about the sun under the action of gravity :
- (A) The period of rotation of the planet around the center of force is proportional to the square of the semi-major axis of the elliptical orbit.
 - (B) The areal velocity is directly proportional to the angular momentum of the planet
 - (C) The period of revolution is proportional to L^2 .
 - (D) The area of the elliptical orbit is proportional to 'L'.
12. Consider a particle moving under the action of the potential in the figure below :

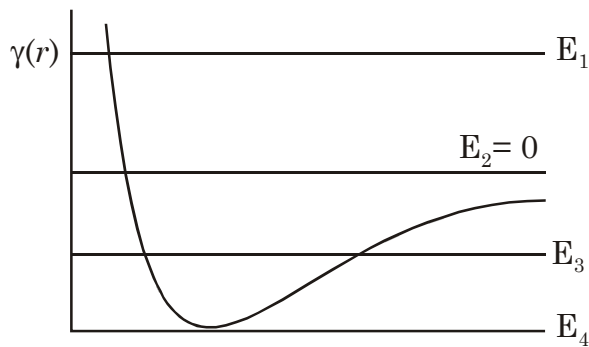

Bounded motion is seen at the energy.

- (A) $E_1 + E_3$
- (B) E_3 and E_4
- (C) E_1 and E_4
- (D) E_2 only

13. The energy levels of one-dimensional harmonic oscillator with potential $v(x) = \frac{1}{2}kx^2$ are given by $h\nu\left(n + \frac{1}{2}\right)$ with $n = 0, 1, 2, 3, \dots$. If the potential is changed to $v(x) = \infty$ for $x < 0$ and $v(x) = \frac{1}{2}kx^2$ for $x > 0$, the energy levels now, will be given by :

- (A) $h\nu\left(n + \frac{3}{2}\right)$
- (B) $2h\nu\left(n + \frac{1}{2}\right)$
- (C) $h\nu\left(n + \frac{1}{2}\right)$, n odd only
- (D) $h\nu\left(n + \frac{1}{2}\right)$, n even only

14. The value of operator $\vec{r} \cdot \vec{p} - \vec{p} \cdot \vec{r}$ in quantum mechanics is :
- (A) $i\hbar$
 (B) zero
 (C) $3i\hbar$
 (D) $\left(\frac{\partial}{\partial x} + \frac{\partial}{\partial y} + \frac{\partial}{\partial z} \right)$
15. The ground state energy of a quantum mechanical system is always :
- (A) Suppressed (lowered) due to second order perturbation
 (B) Suppressed (lowered) due to first order perturbation
 (C) Raised due to second order perturbation
 (D) Raised due to first order perturbation
16. A state of a system with spherical symmetric potential has zero uncertainty in simultaneous measurements of operators L_x and L_y . Which of the following statements is *true* ?
- (A) Such a state can never exist
 (B) The state must be $l = 0$ state
 (C) The state has $l = 1$ with $m = 0$
 (D) The state can not be an eigenstate of L^2 operator
17. Which of the following is an eigenfunction of Linear momentum operator $\frac{\hbar}{i} \frac{\partial}{\partial x}$, such that it describes a particle moving in free space in the direction of negative x -axis, with zero uncertainty in the linear momentum ?
- (A) $\cos kx$
 (B) e^{ikx}
 (C) e^{kx}
 (D) e^{-ikx}

18. The wave function for identical particles is symmetric under particle interchange. Which of the following is a consequence of this property ?
- (A) Pauli-Exclusion principle
 (B) Bose-Einstein condensation
 (C) Heisenberg uncertainty principle
 (D) Bohr-correspondence principle
19. A point charge q is kept at a distance of $2R$ from the centre of a grounded conducting sphere of radius R . The image charge and its distance from the centre are respectively :
- (A) $-q$ and $\frac{R}{2}$
 (B) $-\frac{q}{2}$ and $\frac{R}{2}$
 (C) $-q$ and $\frac{R}{4}$
 (D) $-\frac{q}{2}$ and $\frac{R}{4}$
20. The dimensions of a quantity $\frac{|\vec{E} \times \vec{B}|}{\mu_0}$ are :
- (A) $ML^2 T^{-2}$
 (B) $ML^2 T^{-3}$
 (C) $ML^0 T^{-2}$
 (D) $ML^0 T^{-3}$
21. An electromagnetic wave going through vacuum is described by $\vec{E} = \vec{E}_0 \cos(kz - \omega t)$ and $\vec{B} = \vec{B}_0 \cos(kz - \omega t)$. The relation between E_0 and B_0 is :
- (A) $E_0 B_0 = \frac{\omega}{k}$
 (B) $E_0 B_0 = \omega k$
 (C) $E_0 k = B_0 \omega$
 (D) $E_0 \omega = B_0 k$
22. Electric field at large distance r , from the electric dipole is proportional to :
- (A) r^2
 (B) r^{-2}
 (C) r^{-3}
 (D) r^{-4}

23. An electron enters an uniform electric field region with its velocity perpendicular to the direction of the field. In the field region, the trajectory of the electron is :

- (A) linear
- (B) circular
- (C) parabolic
- (D) helical

24. An electric field associated with an electromagnetic radiation is :

$\vec{E} = (\hat{x}E_x + \hat{y}E_y)e^{i(kz - \omega t)}$. If $E_y = iE_x$, then the electromagnetic radiation is :

- (A) plane polarized
- (B) circularly polarized
- (C) elliptically polarized
- (D) unpolarized

25. The Fermi function of a gas of free electrons has the form :

- (A) $a = \text{const.}, \epsilon = \text{energy}$
- (B) $\frac{1}{\epsilon^2 + a^2} a = \text{const.}, \epsilon = \text{energy}$
- (C) $\frac{a}{\epsilon} a = \text{const.}, \epsilon = \text{energy}$
- (D) $H(\epsilon < \epsilon_f)$

where

$$\textcircled{H}(\epsilon < \epsilon_f) = 1$$

if $\epsilon \leq \epsilon_f$

$$\textcircled{H}(\epsilon < \epsilon_f) = 0$$

if $\epsilon \geq \epsilon_f$

26. A perfect gas initially occupies a volume 'V' with the number of particles 'N' and energy 'E'. The volume is now doubled, keeping 'N' and 'E' constant. The change in entropy will be :

- (A) $Nk_B \ln 2$
- (B) $Nk_B \ln V$
- (C) $2Nk_B \ln V$
- (D) $\frac{1}{2} Nk_B \ln 2V$

27. If the temperature of a black body enclosure is doubled, the total number of photons in the enclosure increases by a factor of :
- (A) 2
(B) 4
(C) 6
(D) 8
28. Consider a system of spin $-\frac{1}{2}$ particles with magnetic moment μ each. In an applied magnetic field, the spin can either be parallel or antiparallel to 'H' with equal probability. If there are 10 such particles, the total number of microstates will be :
- (A) 2^{10}
(B) 10^2
(C) 20
(D) 10
29. For a photon gas, the chemical potential is :
- (A) Large and negative
(B) Zero
(C) Equal to Fermi energy
(D) Large and positive
30. Three distinguishable particles have a total energy of 9ϵ . These particles are distributed over the energy states with energy $0, \epsilon, 2\epsilon, 3\epsilon$ and 4ϵ . The total number of microstates will be :
- (A) 3
(B) 1
(C) 10
(D) 6
31. The noise figure of an amplifier is 3dB. Its noise temperature will be about :
- (A) 145 K
(B) 290 K
(C) 580 K
(D) 870 K
32. Resonance frequency for a free electron in a magnetic field with $B = 1$ tesla is :
- (A) 28.00 GHz
(B) 14.00 GHz
(C) 20.00 GHz
(D) 2.80 GHz
33. Which of the following detectors is used for the measurement of energy of a particle ?
- (A) Ionisation chamber
(B) G.M. counter
(C) Proportional counter
(D) Cerenkov counter

34. Which of the following gauge can measure vacuum in the range 10^{-10} to 10^{-3} torr ?
 (A) McLeod gauge
 (B) Pirani gauge
 (C) Penning gauge
 (D) Ionization gauge
35. In a Millikan oil-drop experiment, one of the drops falls at speed V without field and rises at speed V with field E applied. If the field is made $E/2$, the drop will :
 (A) fall with speed $V/4$
 (B) rise with speed $V/2$
 (C) rise with speed $3V/2$
 (D) remain steady
36. An oscilloscope is on AC mode with no input. If you touch the input a fifty Hertz signal is seen on the screen, what is the origin and how does it get coupled to the input ?
 (A) It originates from the power line and is coupled through conducting air
 (B) It originates from the power line and is coupled through capacitor formed with air as dielectric
 (C) Originates from the power supply of the oscilloscope
 (D) Originates from our body as a result of electrical activity in the heart

37. The minimum value for emitter bypass capacitor C_2 in the following amplifier is.....[operating frequency 2kHz–10 kHz]

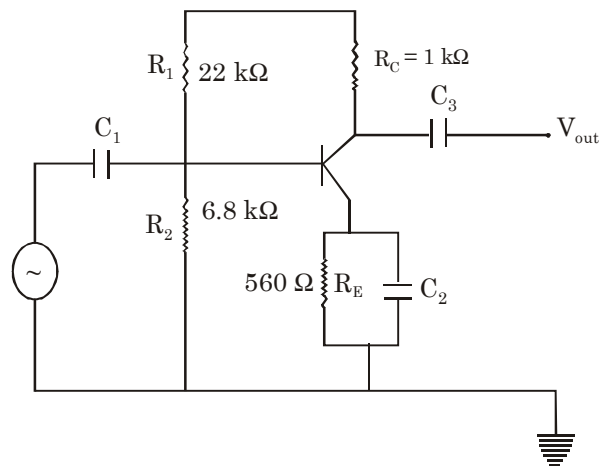

- (A) 1.42 F
 (B) 1.42 mF
 (C) 1.42 μ F
 (D) 1.42 PF
38. What kind of MOSFET mode can be used in the switching mode ?
 (A) Depletion mode
 (B) Cut-off mode
 (C) Saturation mode
 (D) Enhancement mode

39. For a 12-bit A/D converter the range of input signal is 0 to + 10V. The voltage corresponding to 1 LSB is :
- (A) 0
 (B) 0.0012 V
 (C) 0.0024 V
 (D) 0.833 V
40. For one of the following conditions, clocked J-K flip-flop can be used as DIVIDE BY 2 circuit when the pulse train to be divided is applied at clock input :
- (A) J = 1, K = 1 and the flip-flop should have active HIGH inputs
 (B) J = 1, K = 1 and the flip-flop should have active LOW inputs
 (C) J = 0, K = 0 and the flip-flop should have active HIGH inputs
 (D) J = 0, K = 0 and the flip-flop should have active LOW inputs
41. The following can be used a delay circuit :
- (A) Astable multivibrator
 (B) Bistable multivibrator
 (C) Schmitt trigger circuit
 (D) Monostable multivibrator

42. A voltage source $V_{AB} = 40 \sin \omega_t$ is applied to the terminals A and B of the circuit shown below. The impedance by the circuit across the terminal A & B is :

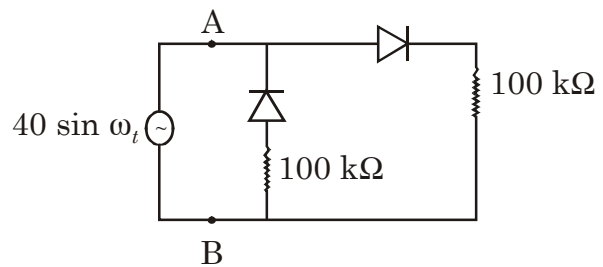

- (A) 50 k Ω
 (B) 100 k Ω
 (C) 150 k Ω
 (D) 200 k Ω
43. For the logic circuit shown in figure the required input condition (A, B, C) to make the output X = 1 is :
- (A) 1, 0, 1
 (B) 0, 0, 1
 (C) 1, 1, 1
 (D) 0, 1, 1

44. Estimate the values of I_c , V_c in the following circuit :

- (A) $I_c = 5.17 \text{ mA}$ $V_c = 0 \text{ V}$
- (B) $I_c = 98 \text{ } \mu\text{A}$ $V_c = 392 \text{ mV}$
- (C) $I_c = 4 \text{ mA}$ $V_c = 16 \text{ V}$
- (D) $I_c = 4 \text{ mA}$ $V_c = 4.7 \text{ V}$

45. The output voltage for the following Op-Amp circuit is :

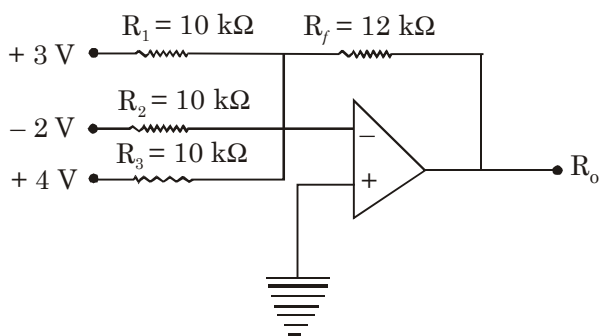

- (A) - 3.6 V
- (B) + 3.6 V
- (C) + 4.2
- (D) - 4.2

46. The following circuit acts as a :

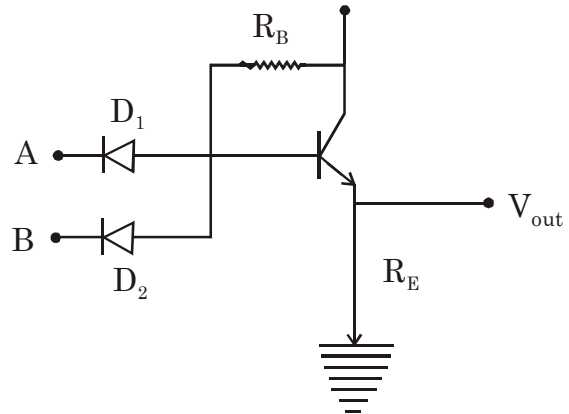

- (A) NAND gate
- (B) NOR gate
- (C) AND gate
- (D) OR gate

47. The shortest wavelength of spectral line in Lyman series is 912 \AA . The shortest wavelength of the spectral line of the Paschen series will be :

- (A) 8208 \AA
- (B) 8028 \AA
- (C) 8828 \AA
- (D) 8820 \AA

48. The normal modes of vibration of CO_2 molecule are observed at 1330 cm^{-1} , 667 cm^{-1} (doubly degenerate) and 2349 cm^{-1} . The total zero point energy of the CO_2 molecule is :
- (A) 31.1 eV
 (B) 0.031 eV
 (C) 0.311 eV
 (D) 3.11 eV
- [data : $h = 6.625 \times 10^{-34} \text{ J.s}$,
 $c = 3 \times 10^8 \text{ m/s}$]
49. How many normal modes of vibration does the water molecule possess ?
- (A) 9
 (B) 3
 (C) 4
 (D) 6
50. Transition for the sodium D_1 line (589.6 nm) is :
- (A) ${}^2P_{3/2} \rightarrow {}^2S_{1/2}$
 (B) ${}^2P_{1/2} \rightarrow {}^2S_{1/2}$
 (C) ${}^2D_{3/2} \rightarrow {}^2P_{1/2}$
 (D) ${}^2D_{5/2} \rightarrow {}^2P_{3/2}$
51. Transition for the sodium D_2 line (589.0 nm) is :
- (A) ${}^2P_{3/2} \rightarrow {}^2S_{1/2}$
 (B) ${}^2P_{1/2} \rightarrow {}^2S_{1/2}$
 (C) ${}^2D_{3/2} \rightarrow {}^2P_{1/2}$
 (D) ${}^2D_{5/2} \rightarrow {}^2P_{3/2}$
52. How many electrons can be put in an atomic shell corresponding to $n = 5$?
- (A) 10
 (B) 24
 (C) 36
 (D) 50
53. How many spectral lines appear in the Zeeman splitting of ${}^2D_{3/2} \rightarrow {}^3P_{1/2}$ transition of sodium ?
- (A) 2
 (B) 3
 (C) 1
 (D) 4
54. What is the ground state of a helium atom ?
- (A) ${}^2P_{1/2}$
 (B) 1S_0
 (C) ${}^1S_{1/2}$
 (D) $2S_0$

55. Consider a hydrogen atom whose electron is in the state with quantum numbers $n = 3, l = 2$. To what lower states are radiative transitions possible ?

- (A) $n = 3, l = 1$ and $n = 2, l = 1$
 (B) $n = 3, l = 2$ and $n = 2, l = 0$
 (C) $n = 2, l = 0$ and $n = 1, l = 0$
 (D) $n = 3, l = 0$ and $n = 1, l = 0$

56. A three level system of atoms has N_1 atoms in level E_1 , N_2 in level E_2 and N_3 in level E_3 . If $N_2 > N_1 > N_3$ and $E_1 < E_2 < E_3$, laser emission is possible between the levels :

- (A) $E_3 \rightarrow E_1$
 (B) $E_2 \rightarrow E_1$
 (C) $E_3 \rightarrow E_2$
 (D) $E_2 \rightarrow E_3$

57. The magnetic susceptibility of a paramagnetic substance shows the following behaviour as a function of 'T'.

- (A) Hyperbolic behaviour
 (B) Parabolic behaviour
 (C) is identically zero
 (D) shows constant behaviour

58. The plasma frequency ω_p for the electron gas is :

- (A) $\propto \frac{1}{\sqrt{m}}$
 (B) $\propto m$
 (C)

(D) independent of m ,

where m is the mass of electron.

59. The energy dissipated per second in a dielectric per unit volume is proportional to :

- (A) ω
 (B) $\frac{1}{\omega}$
 (C) ω^2
 (D) $\frac{1}{\omega^2}$

where ω is the angular frequency

60. The probability of occupation of an energy level E , when $E - E_F = kT$, is :
- (A) 0.73
(B) 0.63
(C) 0.27
(D) 0.50
61. A unit cell of a cubic lattice has an edge of 3.6\AA . How many unit cells are present in a lump of 1cm^3 ?
- (A) 2.14×10^{22}
(B) 1.42×10^{23}
(C) 6.00×10^{12}
(D) 6.00×10^{23}
62. The first Brillouin zone of the body-centered cubic lattice is :
- (A) truncated octahedron
(B) rhombohedron
(C) tetrahedron
(D) rhombic dodecahedron
63. The magnetic field \bar{B} inside a superconductor maintained at a temperature T less than the critical temperature T_c :
- (A) behaves linearly as a function of the applied field \bar{H} , up to a critical field H_c
(B) vanishes identically upto the critical field H_c
(C) is a non-zero constant below H_c
(D) shows parabolic behaviour below H_c and a gap above H_c

64. Above Curie temperature, the ferromagnetic material exhibits B-H curve in the form of :
- (A) B-H loop
(B) Straight line
(C) Circle
(D) Ellipse
65. A d.c. voltage of $1 \mu\text{V}$ applied across a junction formed by sandwiching a thin layer of insulator between two superconductors causes *rf* current oscillations of a frequency of :
- (A) 48.36 MHz
(B) 4836.00 MHz
(C) 4.836 MHz
(D) 483.6 MHz
66. In a semiconductor, the effective masses of holes and electrons are identical. The position of the Fermi level at absolute zero temperature is :
- (A) near the top of the valence band
(B) near the bottom of the conduction band
(C) midway between valence and conduction bands
(D) below the valence band
67. Among the following nuclei, which has the maximum binding energy per nucleon ?
- ${}^8_{16}\text{O}$, ${}^{26}_{56}\text{Fe}$, ${}^{82}_{208}\text{Pb}$, ${}^{92}_{235}\text{U}$
- (A) ${}^8_{16}\text{O}$
(B) ${}^{26}_{56}\text{Fe}$
(C) ${}^{82}_{208}\text{Pb}$
(D) ${}^{92}_{235}\text{U}$

68. Radius of nucleus ^{27}Al is 3.6 Fermi.

The approximate nuclear radius of ^{64}Cu is :

- (A) 8.5 Fermi
- (B) 7.2 Fermi
- (C) 4.8 Fermi
- (D) 3.6 Fermi

69. The magic numbers in nuclear physics arise mainly due to :

- (A) dipole-dipole interaction
- (B) spin-orbit interaction
- (C) short range character of nuclear force
- (D) coulomb interaction

70. The decay chain for the $^{238}_{92}\text{U}$ nucleus involves eight α -decays and six β^- decays. The final nucleus at the end of the process will have :

- (A) $Z = 88, A = 206$
- (B) $Z = 84, A = 224$
- (C) $Z = 82, A = 206$
- (D) $Z = 76, A = 200$

71. Which of the following particles was assumed to be involved in β -decay process, in order to explain continuous spectrum of β -rays ?

- (A) Higg's Boson
- (B) Neutrino
- (C) Pion
- (D) Muon

72. Which of the following statements is *true* for a compound nuclear reaction ?

- (A) The formation of the compound nucleus and its break-up are independent
- (B) The break-up of compound nucleus is instantaneous (very short life time)
- (C) The break-up of a compound nucleus depends on the channel of its formation
- (D) The Q-value of compound nuclear reaction is always negative

73. According to the liquid-drop model, the surface energy part is proportional to :

- (A) $A^{2/3}$
- (B) $A^{1/3}$
- (C) A
- (D) A^2

74. What is the possible values of Iso Spin $-I$ and its Z-component I_3 for the following system of a particle

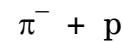

- (A) $I_3 = -\frac{1}{2}, I = 1$
- (B) $I_3 = -\frac{1}{2}, I = \frac{3}{2}$
- (C) $I_3 = -\frac{3}{2}, I = -\frac{1}{2}$
- (D) $I_3 = \frac{1}{2}, I = \frac{1}{2}$

75. The quark structure of Δ^{++} is :

- (A) UUU
- (B) UdU
- (C) SSS
- (D) ddd

DEC-32313/III

ROUGH WORK